

Technical Support Center: Assessing and Mitigating Sp-cAMPS-AM Induced Cell Stress

Author: BenchChem Technical Support Team. **Date:** April 2026

Compound of Interest

Compound Name: *Sp-cAMPS-AM*

Cat. No.: *B15544168*

[Get Quote](#)

Welcome to the technical support center for **Sp-cAMPS-AM**. This resource is designed for researchers, scientists, and drug development professionals to provide guidance on the effective use of **Sp-cAMPS-AM**, with a focus on assessing and mitigating potential cell stress. Here you will find troubleshooting guides, frequently asked questions (FAQs), detailed experimental protocols, and quantitative data to support your research.

Frequently Asked Questions (FAQs)

Q1: What is **Sp-cAMPS-AM** and how does it work?

Sp-cAMPS-AM is a cell-permeant analog of cyclic AMP (cAMP).[1] Its acetoxymethyl (AM) ester modification allows it to efficiently cross the cell membrane. Once inside the cell, endogenous esterases cleave the AM group, releasing the active, membrane-impermeant Sp-cAMPS. Sp-cAMPS is a potent activator of cAMP-dependent Protein Kinase A (PKA) and is resistant to degradation by phosphodiesterases (PDEs), leading to sustained PKA activation.

Q2: Why am I observing high levels of cytotoxicity with **Sp-cAMPS-AM** treatment?

High concentrations of **Sp-cAMPS-AM** can lead to excessive and prolonged PKA activation, which can induce cell cycle arrest or apoptosis depending on the cell type and experimental

context.[2] Off-target effects, though less common, can also contribute to cytotoxicity at higher concentrations. It is also crucial to ensure the purity of the **Sp-cAMPS-AM** solution, as impurities or degradation products can be toxic to cells.

Q3: What are the typical working concentrations for **Sp-cAMPS-AM**?

The optimal working concentration is highly dependent on the cell type and the desired biological outcome. Generally, concentrations ranging from 10 μM to 200 μM are used in cell culture experiments.[2] Cytotoxicity may become a concern at concentrations above 100 μM in some cell lines.[2] A dose-response experiment is always recommended to determine the optimal concentration for your specific experimental setup.

Q4: How can I confirm that PKA is being activated in my experiment?

PKA activation can be confirmed by assessing the phosphorylation of its downstream targets. A common method is to perform a Western blot to detect the phosphorylation of CREB (cAMP response element-binding protein) at the Serine-133 residue. An increase in pCREB (Ser133) levels following **Sp-cAMPS-AM** treatment indicates PKA activation.

Q5: What are the key indicators of **Sp-cAMPS-AM**-induced cell stress?

Key indicators of cell stress include a decrease in cell viability, an increase in apoptotic markers (e.g., cleaved caspase-3, Annexin V staining), and the activation of the unfolded protein response (UPR) or ER stress markers (e.g., CHOP, cleaved caspase-12).

Troubleshooting Guide

Issue	Possible Cause	Suggested Solution
High Cell Death at Desired Working Concentration	Concentration is above the cytotoxic threshold for your cell line.	Perform a dose-response curve to determine the IC50 value for cytotoxicity. Use the lowest effective concentration that elicits the desired biological response. ^[2]
Prolonged exposure to high concentrations.	Optimize the incubation time. Shorter exposure may be sufficient to activate the PKA pathway without causing significant cell death.	
Off-target effects of the compound.	Include a control with the PKA inhibitor Rp-cAMPS to confirm the effect is PKA-dependent.	
Inconsistent Results Between Experiments	Instability or degradation of Sp-cAMPS-AM in the culture medium.	Prepare fresh stock solutions and use a more metabolically stable analog like Sp-8-Br-cAMPS for long-term experiments.
Variability in cell health or density.	Standardize cell culture protocols, including passage number, seeding density, and growth conditions.	
No Observable Effect After Treatment	Insufficient concentration of Sp-cAMPS-AM.	Perform a dose-response curve to determine the optimal concentration for your cell type.
Degradation of Sp-cAMPS-AM.	Prepare fresh stock solutions and store them in aliquots at -20°C or -80°C, avoiding repeated freeze-thaw cycles.	

High phosphodiesterase (PDE) activity in cells.

Consider co-treatment with a broad-spectrum PDE inhibitor like IBMX.

Quantitative Data

Table 1: Sp-cAMPS-AM Cytotoxicity (IC50) in Various Cell Lines

Note: IC50 values for **Sp-cAMPS-AM** are highly cell-type and context-dependent. The following table provides an example of expected ranges. It is crucial to determine the IC50 experimentally for your specific cell line.

Cell Line	Cell Type	Incubation Time (hr)	IC50 (µM)
PC12	Rat Pheochromocytoma	24	50 - 150
HTB-26	Human Breast Cancer	48	10 - 50
PC-3	Human Prostate Cancer	48	10 - 50
HepG2	Human Liver Cancer	48	10 - 50
HCEC	Normal Intestinal Epithelial	48	> 50

Experimental Protocols

Protocol 1: Assessing Cell Viability using MTT Assay

This protocol is for determining the cytotoxic effects of **Sp-cAMPS-AM** on a cell line.

Materials:

- Cells of interest

- 96-well plates
- **Sp-cAMPS-AM**
- MTT (3-(4,5-dimethylthiazol-2-yl)-2,5-diphenyltetrazolium bromide) solution (5 mg/mL in PBS)
- DMSO
- Microplate reader

Procedure:

- **Cell Seeding:** Seed cells into a 96-well plate at a density of 5,000-10,000 cells/well in 100 μ L of complete medium and incubate for 24 hours.
- **Compound Treatment:** Prepare serial dilutions of **Sp-cAMPS-AM** in complete culture medium. Remove the old medium and add 100 μ L of the **Sp-cAMPS-AM** dilutions to the respective wells. Include untreated cells as a negative control and a vehicle control (e.g., DMSO) if applicable.
- **Incubation:** Incubate the plate for the desired exposure time (e.g., 24, 48, or 72 hours).
- **MTT Incubation:** Add 10 μ L of 5 mg/mL MTT solution to each well and incubate for 2-4 hours at 37°C.
- **Solubilization of Formazan:** Carefully remove the medium and add 100 μ L of DMSO to each well to dissolve the formazan crystals.
- **Absorbance Measurement:** Measure the absorbance at 570 nm using a microplate reader.
- **Data Analysis:** Calculate the percentage of cell viability relative to the untreated control and plot a dose-response curve to determine the IC₅₀ value.

Protocol 2: Western Blot Analysis of Apoptosis and ER Stress Markers

This protocol is for detecting the expression of cleaved caspase-3 and CHOP as markers of apoptosis and ER stress, respectively.

Materials:

- Cells treated with **Sp-cAMPS-AM**
- RIPA lysis buffer with protease and phosphatase inhibitors
- BCA protein assay kit
- SDS-PAGE gels
- PVDF or nitrocellulose membranes
- Blocking buffer (e.g., 5% non-fat milk or BSA in TBST)
- Primary antibodies (anti-cleaved caspase-3, anti-CHOP, anti- β -actin)
- HRP-conjugated secondary antibody
- ECL substrate and imaging system

Procedure:

- Cell Lysis: After treatment with **Sp-cAMPS-AM**, wash cells with cold PBS and lyse them using RIPA buffer.
- Protein Quantification: Determine the protein concentration of each lysate using a BCA assay.
- SDS-PAGE and Western Blotting:
 - Load equal amounts of protein (20-30 μ g) onto an SDS-PAGE gel.
 - Transfer the separated proteins to a PVDF or nitrocellulose membrane.
 - Block the membrane with blocking buffer for 1 hour at room temperature.

- Incubate the membrane with primary antibodies against cleaved caspase-3 and CHOP overnight at 4°C. Use an antibody against a housekeeping protein (e.g., β -actin) for a loading control.
- Wash the membrane with TBST and incubate with the appropriate HRP-conjugated secondary antibody for 1 hour at room temperature.
- Detect the protein bands using an ECL substrate and an imaging system.
- Data Analysis: Quantify the band intensities and normalize them to the loading control to determine the relative expression levels of the target proteins.

Protocol 3: Mitigating Sp-cAMPS-AM-Induced Cytotoxicity with a PKA Inhibitor

This protocol describes a co-treatment strategy to confirm that the observed cytotoxicity is PKA-dependent.

Materials:

- Cells of interest
- **Sp-cAMPS-AM**
- Rp-cAMPS (PKA inhibitor)
- Reagents for cell viability assay (e.g., MTT assay)

Procedure:

- Cell Seeding: Seed cells as described in Protocol 1.
- Co-treatment:
 - Prepare a concentration of **Sp-cAMPS-AM** that is known to induce cytotoxicity (e.g., at or above the IC50 value).

- Prepare a concentration of Rp-cAMPS (typically in the same concentration range as **Sp-cAMPS-AM**).
- Treat cells with:
 - **Sp-cAMPS-AM** alone
 - Rp-cAMPS alone
 - **Sp-cAMPS-AM** and Rp-cAMPS in combination
 - Untreated and vehicle controls
- Incubation and Viability Assessment: Incubate the cells for the desired duration and assess cell viability using the MTT assay as described in Protocol 1.
- Data Analysis: Compare the cell viability in the different treatment groups. A rescue of cell viability in the co-treatment group compared to the **Sp-cAMPS-AM** alone group suggests that the cytotoxicity is PKA-mediated.

Visualizations

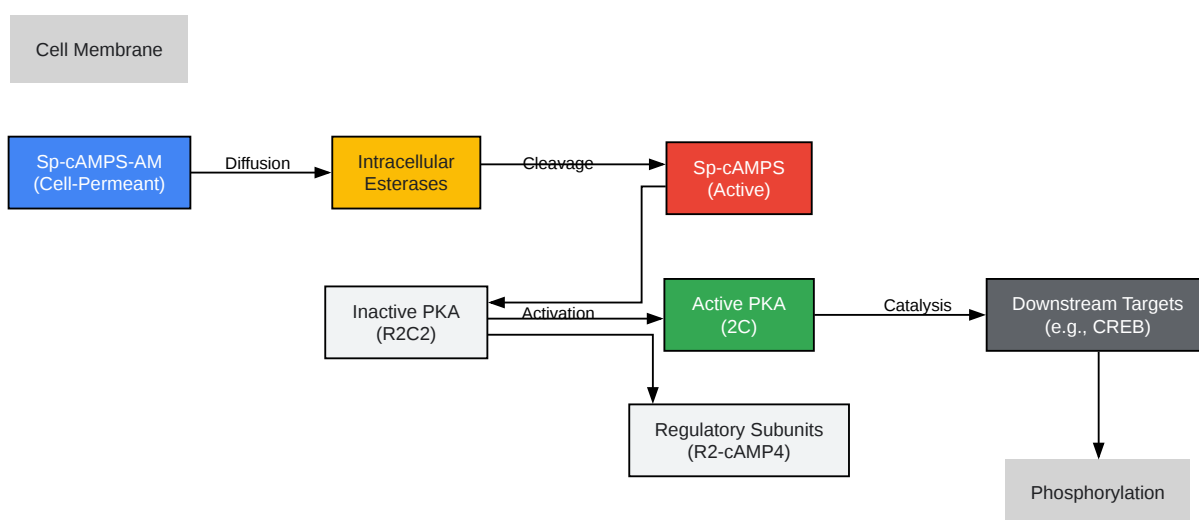

[Click to download full resolution via product page](#)

Caption: **Sp-cAMPS-AM** Mechanism of Action.

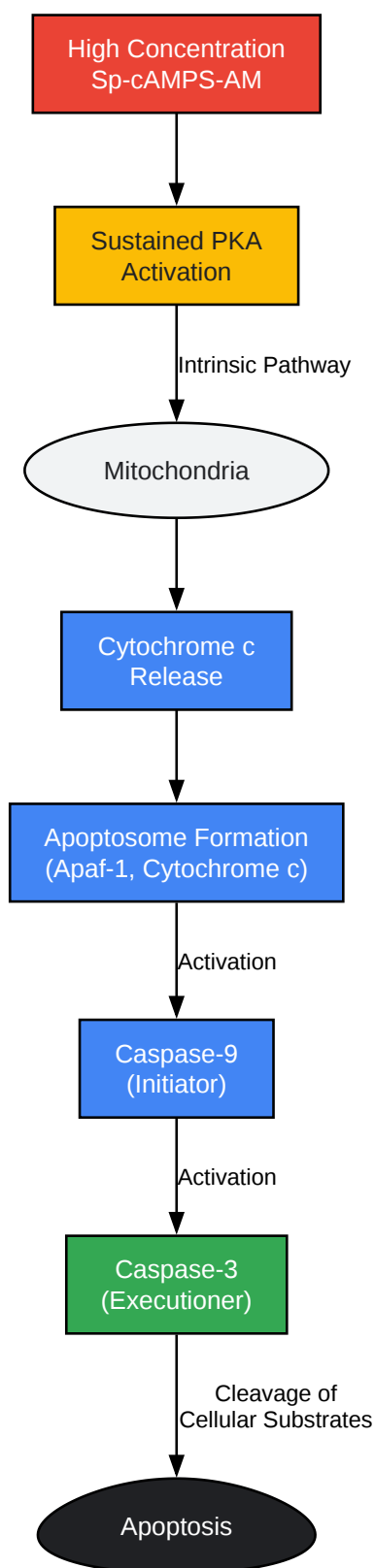

[Click to download full resolution via product page](#)

Caption: **Sp-cAMPS-AM** Induced Apoptosis.

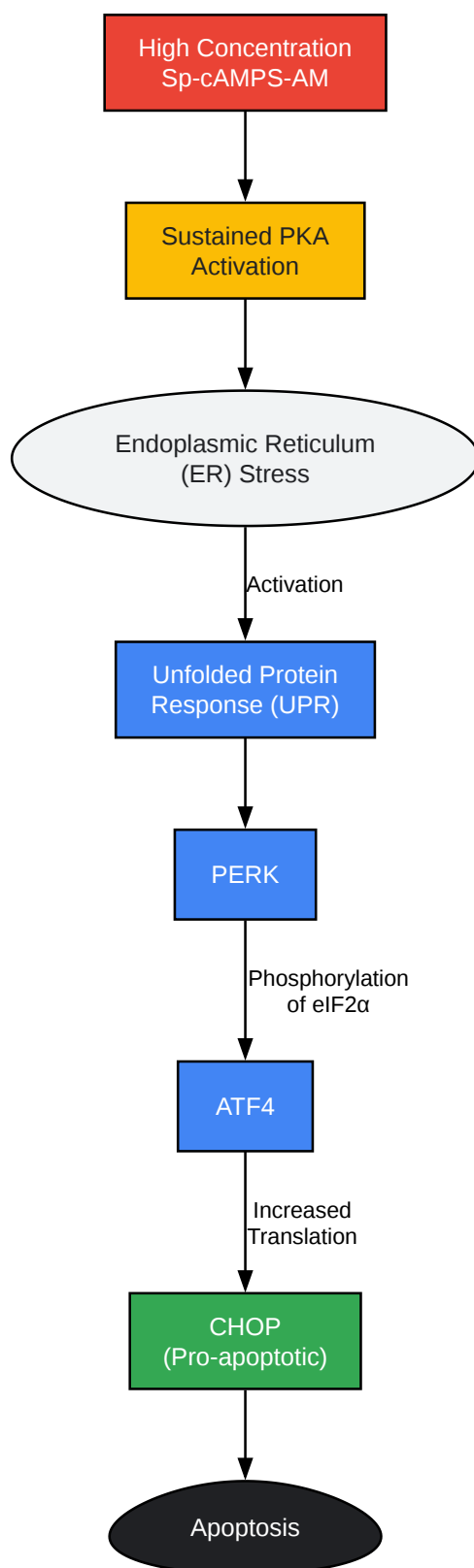

[Click to download full resolution via product page](#)

Caption: **Sp-cAMPS-AM Induced ER Stress.**

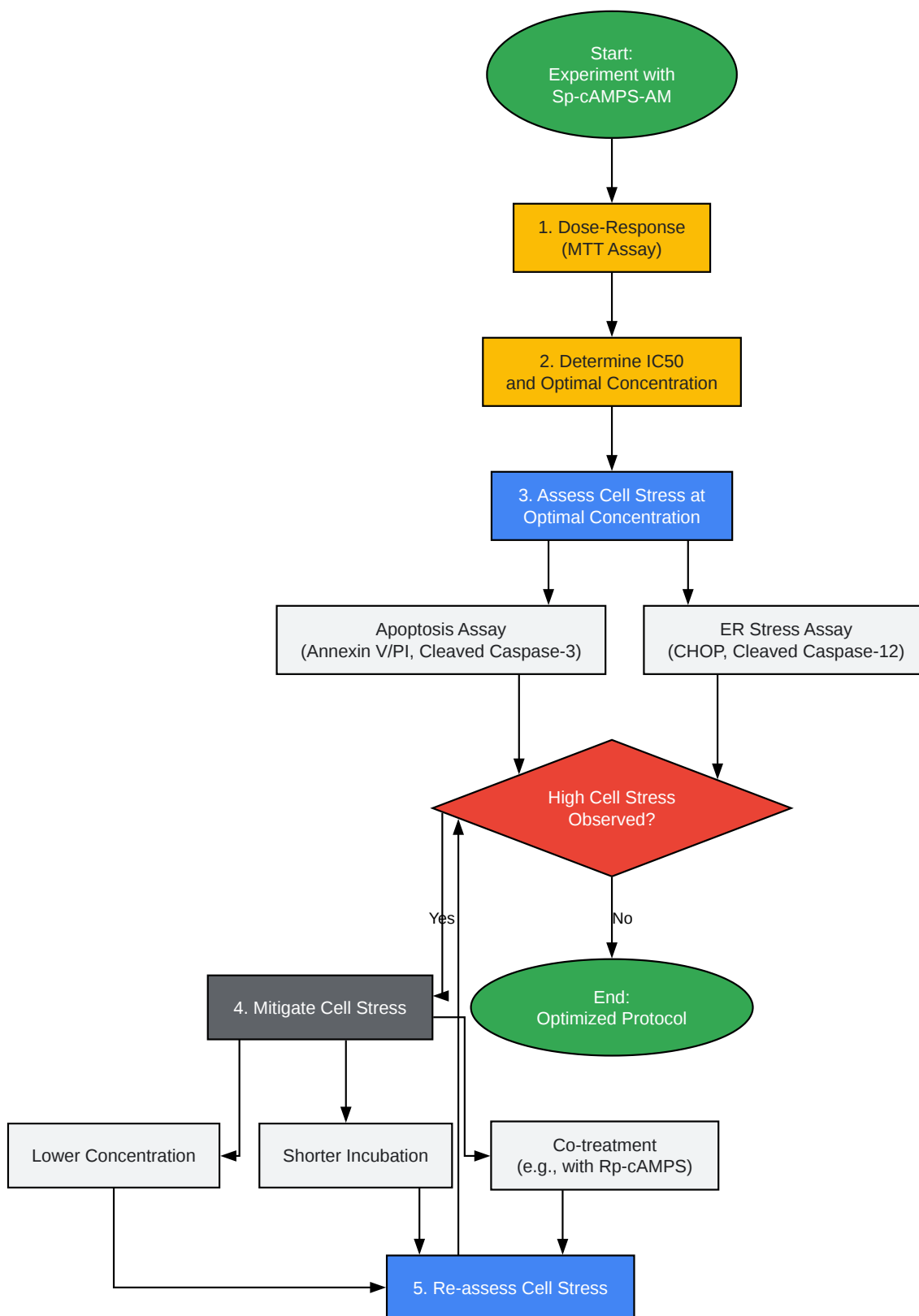

[Click to download full resolution via product page](#)

Caption: Workflow for Assessing and Mitigating Cell Stress.

Need Custom Synthesis?

BenchChem offers custom synthesis for rare earth carbides and specific isotopic labeling.

Email: info@benchchem.com or [Request Quote Online](#).

References

- 1. Sp-cAMPS-AM BIOLOG Life Science Institute [biolog.de]
- 2. benchchem.com [benchchem.com]
- To cite this document: BenchChem. [Technical Support Center: Assessing and Mitigating Sp-cAMPS-AM Induced Cell Stress]. BenchChem, [2026]. [Online PDF]. Available at: [<https://www.benchchem.com/product/b15544168/docs#technical-support-center-assessing-and-mitigating-sp-camps-am-induced-cell-stress>]

Disclaimer & Data Validity:

The information provided in this document is for Research Use Only (RUO) and is strictly not intended for diagnostic or therapeutic procedures. While BenchChem strives to provide accurate protocols, we make no warranties, express or implied, regarding the fitness of this product for every specific experimental setup.

Technical Support: The protocols provided are for reference purposes. Unsure if this reagent suits your experiment?

Need Industrial/Bulk Grade? [Request Custom Synthesis Quote](#)

BenchChem

Our mission is to be the trusted global source of essential and advanced chemicals, empowering scientists and researchers to drive progress in science and industry.

Contact

Address: 3281 E Guasti Rd

Ontario, CA 91761, United States

Phone: (601) 213-4426

Email: info@benchchem.com

[Contact our Ph.D. Support Team for a compatibility check](#)