

# Reproducibility of MD-222 Experimental Results: A Comparative Guide

**Author:** BenchChem Technical Support Team. **Date:** April 2026

## Compound of Interest

Compound Name: MD-222  
Cat. No.: B15544443

[Get Quote](#)

For Researchers, Scientists, and Drug Development Professionals

This guide provides a comparative analysis of the experimental results for **MD-222**, a first-in-class PROTAC (Proteolysis Targeting Chimera) degrader of the E3 ubiquitin ligase MDM2. The objective is to offer a comprehensive overview of its performance in relation to other MDM2-targeting alternatives, supported by available experimental data. This document summarizes key quantitative findings, details experimental methodologies for pivotal assays, and presents visual diagrams of the relevant signaling pathway and experimental workflows to aid in the understanding and potential reproduction of these findings.

## Executive Summary

**MD-222** is a potent and effective degrader of the MDM2 protein, leading to the activation of the p53 tumor suppressor pathway. Experimental data demonstrates its ability to induce rapid degradation of MDM2 and inhibit the growth of cancer cell lines with wild-type p53 at nanomolar concentrations. This guide compares **MD-222** with its structural analog and fellow PROTAC, MD-224, as well as the MDM2 inhibitor MI-1061 and the molecular glue degrader MG-277. While precise degradation parameters (DC50 and Dmax) for MDM2 by **MD-222** are not consistently published, its high potency is a recurring finding in the literature.

## Data Presentation

The following tables summarize the quantitative data gathered from various experimental studies, providing a basis for comparing the efficacy of **MD-222** and its alternatives.

Table 1: In Vitro Cell Growth Inhibition

Compound	Cell Line	p53 Status	IC50 (nM)	Citation
MD-222	RS4;11	Wild-type	5.5	[1]
RS4;11/IRMI-2	Mutated	No effect	[1]	
MDA-MB-231	Mutated	No effect	[1]	
MDA-MB-468	Mutated	No effect	[1]	
MD-224	RS4;11	Wild-type	1.5	[2][3]
MOLM-13	Wild-type	4.4	[3]	
MV4-11	Wild-type	6.2	[3]	
EOL-1	Wild-type	33.1	[3]	
MI-1061	SJSA-1	Wild-type	100	[4]
HCT-116 p53+/+	Wild-type	250	[4]	
HCT-116 p53-/-	Null	>10,000	[4]	
MG-277	RS4;11	Wild-type	3.5	
RS4;11/IRMI-2	Mutated	3.4		

Table 2: Protein Degradation Efficiency

Compound	Target Protein	Cell Line	DC50	Dmax	Citation
MD-222	MDM2	RS4;11	Not explicitly reported	Not explicitly reported	
MD-224	MDM2	Human leukemia cells	< 1 nM (effective degradation)	Not consistently reported	[2][3]
MG-277	GSPT1	RS4;11	1.3 nM	Not explicitly reported	

Note: While specific DC50 and Dmax values for MDM2 degradation by **MD-222** and MD-224 are not consistently available in the reviewed literature, their high potency at sub-nanomolar to low nanomolar concentrations is a key finding.[5]

## Experimental Protocols

Detailed methodologies are crucial for the reproducibility of experimental results. The following are generalized protocols for key experiments cited in the evaluation of **MD-222** and its alternatives, based on standard laboratory practices. For specific parameters, it is recommended to consult the supplementary information of the cited publications.

## Western Blot Analysis for MDM2 Degradation

This protocol outlines the steps to assess the levels of MDM2 and p53 proteins in cell lysates following treatment with MDM2 degraders.

- Cell Culture and Treatment:
  - Culture human cancer cell lines (e.g., RS4;11) in appropriate media and conditions.
  - Seed cells in 6-well plates and allow them to adhere overnight.
  - Treat cells with varying concentrations of **MD-222** or other compounds for the desired time points (e.g., 1-2 hours for MDM2 degradation).

- Cell Lysis:
  - Wash cells with ice-cold phosphate-buffered saline (PBS).
  - Lyse the cells in RIPA buffer supplemented with protease and phosphatase inhibitors.
  - Scrape the cells and transfer the lysate to a microcentrifuge tube.
  - Centrifuge at 14,000 rpm for 15 minutes at 4°C to pellet cell debris.
  - Collect the supernatant containing the protein lysate.
- Protein Quantification:
  - Determine the protein concentration of each lysate using a BCA protein assay kit.
- SDS-PAGE and Protein Transfer:
  - Denature equal amounts of protein (e.g., 20-30 µg) by boiling in Laemmli sample buffer.
  - Separate the proteins by size using SDS-polyacrylamide gel electrophoresis (SDS-PAGE).
  - Transfer the separated proteins to a polyvinylidene difluoride (PVDF) membrane.
- Immunoblotting:
  - Block the membrane with 5% non-fat milk or bovine serum albumin (BSA) in Tris-buffered saline with Tween 20 (TBST) for 1 hour at room temperature.
  - Incubate the membrane with primary antibodies against MDM2, p53, and a loading control (e.g., GAPDH or β-actin) overnight at 4°C.
  - Wash the membrane three times with TBST.
  - Incubate the membrane with the appropriate horseradish peroxidase (HRP)-conjugated secondary antibody for 1 hour at room temperature.
  - Wash the membrane three times with TBST.

- Detection:
  - Visualize the protein bands using an enhanced chemiluminescence (ECL) detection system and imaging equipment.
  - Quantify band intensities using densitometry software.

## Cell Viability Assay (MTT Assay)

This protocol is used to determine the effect of **MD-222** and other compounds on cell proliferation and viability.

- Cell Seeding:
  - Seed cells in a 96-well plate at a predetermined optimal density.
  - Allow the cells to attach and grow for 24 hours.
- Compound Treatment:
  - Treat the cells with a serial dilution of the test compounds (e.g., **MD-222**) for a specified period (e.g., 4 days).[1]
  - Include a vehicle-only control.
- MTT Incubation:
  - Add MTT (3-(4,5-dimethylthiazol-2-yl)-2,5-diphenyltetrazolium bromide) solution to each well and incubate for 3-4 hours at 37°C.
- Formazan Solubilization:
  - Add a solubilization solution (e.g., DMSO or a detergent-based solution) to each well to dissolve the formazan crystals.
- Absorbance Measurement:
  - Measure the absorbance of each well at a wavelength of 570 nm using a microplate reader.

- Data Analysis:
  - Calculate the percentage of cell viability relative to the vehicle-treated control cells.
  - Determine the IC50 value (the concentration of a drug that inhibits cell growth by 50%) by plotting a dose-response curve.

## Mandatory Visualization

The following diagrams were generated using Graphviz (DOT language) to visually represent key concepts.

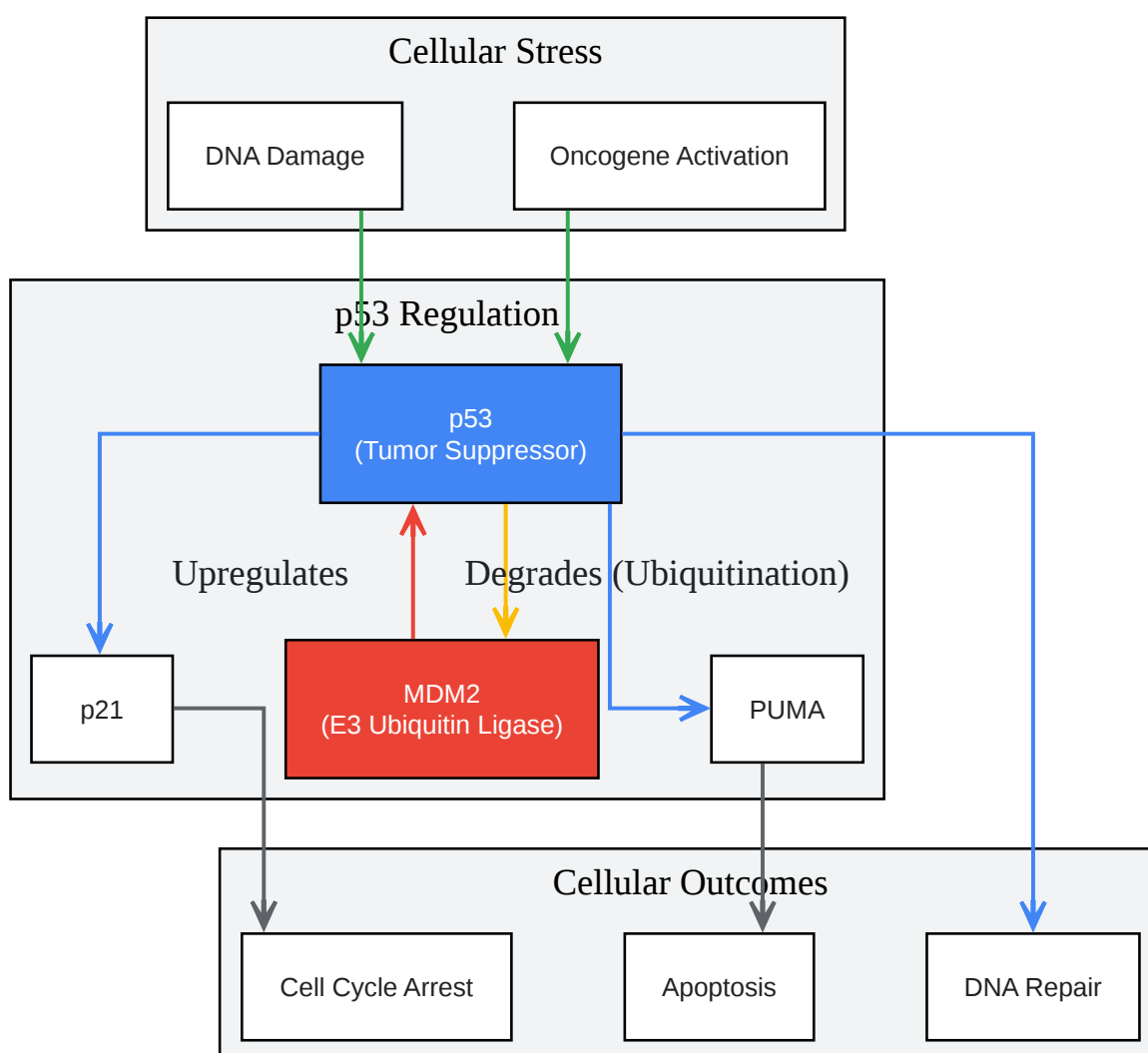

[Click to download full resolution via product page](#)

## MDM2-p53 signaling pathway.

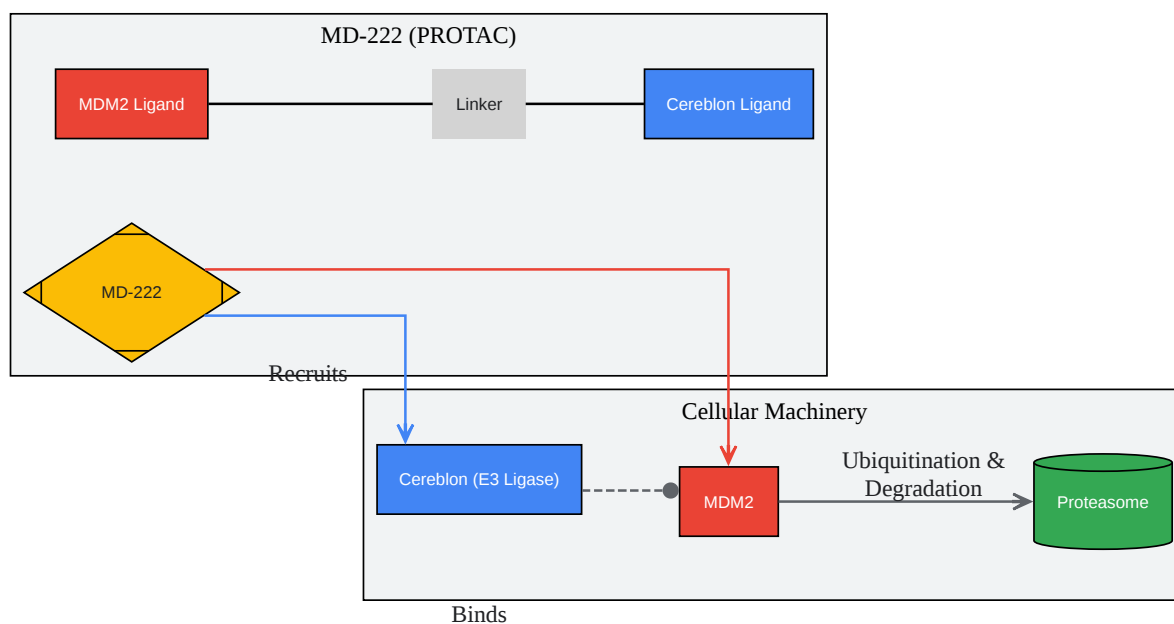

[Click to download full resolution via product page](#)

Mechanism of action for **MD-222**.

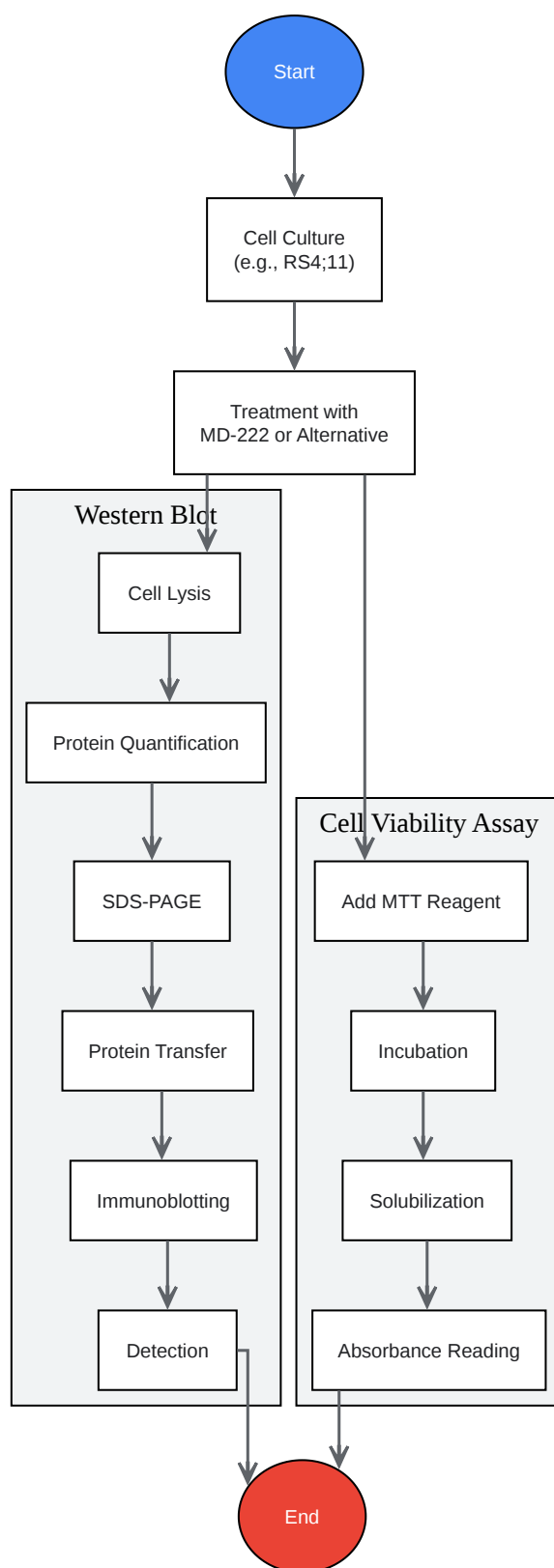

[Click to download full resolution via product page](#)

General experimental workflow.

### Need Custom Synthesis?

BenchChem offers custom synthesis for rare earth carbides and specific isotopic labeling.

Email: [info@benchchem.com](mailto:info@benchchem.com) or [Request Quote Online](#).

## References

- [1. medchemexpress.com \[medchemexpress.com\]](https://www.medchemexpress.com)
- [2. medchemexpress.com \[medchemexpress.com\]](https://www.medchemexpress.com)
- [3. Discovery of MD-224 as a First-in-Class, Highly Potent and Efficacious PROTAC MDM2 Degradable Capable of Achieving Complete and Durable Tumor Regression - PMC \[pmc.ncbi.nlm.nih.gov\]](#)
- [4. medchemexpress.com \[medchemexpress.com\]](https://www.medchemexpress.com)
- [5. benchchem.com \[benchchem.com\]](https://www.benchchem.com)
- To cite this document: BenchChem. [Reproducibility of MD-222 Experimental Results: A Comparative Guide]. BenchChem, [2026]. [Online PDF]. Available at: [\[https://www.benchchem.com/product/b15544443/docs#reproducibility-of-md-222-experimental-results-a-comparative-guide\]](https://www.benchchem.com/product/b15544443/docs#reproducibility-of-md-222-experimental-results-a-comparative-guide)

---

### Disclaimer & Data Validity:

The information provided in this document is for Research Use Only (RUO) and is strictly not intended for diagnostic or therapeutic procedures. While BenchChem strives to provide accurate protocols, we make no warranties, express or implied, regarding the fitness of this product for every specific experimental setup.

**Technical Support:** The protocols provided are for reference purposes. Unsure if this reagent suits your experiment?

**Need Industrial/Bulk Grade?** [Request Custom Synthesis Quote](#)

# BenchChem

Our mission is to be the trusted global source of essential and advanced chemicals, empowering scientists and researchers to drive progress in science and industry.

## Contact

Address: 3281 E Guasti Rd

Ontario, CA 91761, United States

Phone: (601) 213-4426

Email: [info@benchchem.com](mailto:info@benchchem.com)

[Contact our Ph.D. Support Team for a compatibility check](#)