

MU1742: Application Notes and Protocols for Cell-Based Assays

Author: BenchChem Technical Support Team. **Date:** April 2026

Compound of Interest

Compound Name: MU1742
Cat. No.: B15544333

[Get Quote](#)

For Researchers, Scientists, and Drug Development Professionals

Abstract

MU1742 is a potent and selective chemical probe for Casein Kinase 1 delta (CK1 δ) and epsilon (CK1 ϵ), with secondary activity against CK1 α at higher concentrations.[1] As a critical regulator of the Wnt/ β -catenin signaling pathway, **MU1742** serves as an invaluable tool for investigating cellular processes such as cell proliferation, differentiation, and migration. These application notes provide detailed protocols for utilizing **MU1742** in various cell-based assays to elucidate its mechanism of action and functional consequences.

Introduction

Casein Kinase 1 (CK1) is a family of serine/threonine kinases that play a pivotal role in numerous cellular signaling pathways, most notably the Wnt/ β -catenin pathway.[2] Dysregulation of CK1 activity has been implicated in various diseases, including cancer. **MU1742** has been identified as a highly selective inhibitor of CK1 δ and CK1 ϵ , making it an excellent tool for studying the specific roles of these isoforms in cellular functions.[1] This document outlines detailed experimental protocols for cell culture and key functional assays to characterize the effects of **MU1742**.

Data Presentation

In Vitro Kinase Inhibition

| Target | IC50 (nM) |
|--------|-----------|
| CK1δ | 6.1 |
| CK1ε | 27.7 |
| CK1α1 | 7.2 |
| CK1α1L | 520 |

Table 1: In vitro inhibitory potency of **MU1742** against various CK1 isoforms.[3]

Cellular Activity

| Cell Line | Assay | Observation |
|----------------|-----------------------------------|---|
| HEK293 | NanoBRET Target Engagement | Effective in cellulo target engagement |
| Leukemic Cells | Trans-well Migration (with CCL19) | Inhibition of chemotaxis |
| JURKAT | Alamar Blue | No significant cytotoxicity up to 10 μM over 24 hours |
| HEK293 | Alamar Blue | No significant cytotoxicity up to 10 μM over 24 hours |

Table 2: Summary of observed cellular activities of **MU1742** in various assays.[2][3]

Signaling Pathway and Experimental Workflow Diagrams

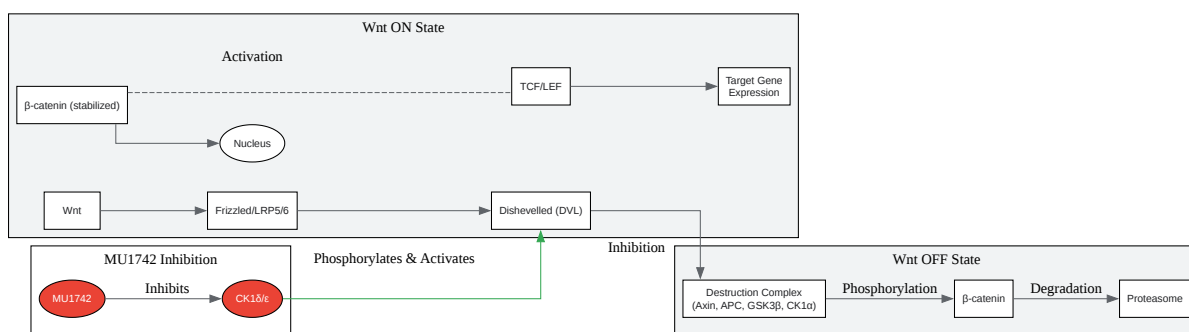

[Click to download full resolution via product page](#)

Caption: Wnt/β-catenin signaling pathway and the inhibitory action of **MU1742**.

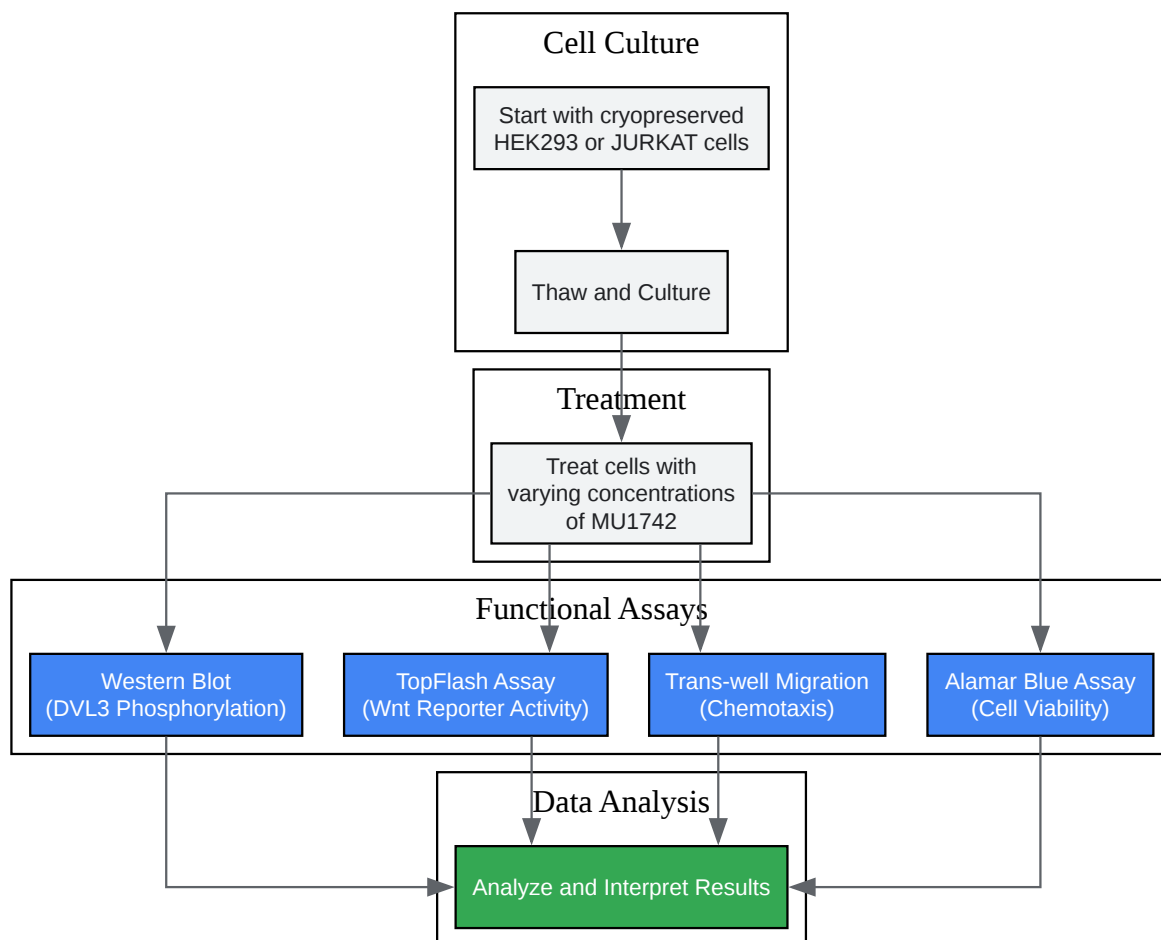

[Click to download full resolution via product page](#)

Caption: General experimental workflow for characterizing **MU1742**.

Experimental Protocols

Cell Culture

a. HEK293T Cells

- Media: Dulbecco's Modified Eagle Medium (DMEM) supplemented with 10% Fetal Bovine Serum (FBS) and 1% Penicillin-Streptomycin.

- Culture Conditions: Incubate at 37°C in a humidified atmosphere with 5% CO₂.
- Subculturing: Passage cells when they reach 80-90% confluency. Wash with PBS, detach with Trypsin-EDTA, and re-seed at a 1:10 to 1:20 ratio.[4]

b. JURKAT Cells

- Media: RPMI-1640 medium supplemented with 10% FBS and 1% Penicillin-Streptomycin.
- Culture Conditions: Incubate at 37°C in a humidified atmosphere with 5% CO₂. [5]
- Subculturing: Maintain cell density below 1 x 10⁶ cells/mL. [5] Split the culture every 2-3 days by centrifuging the cell suspension, removing the supernatant, and resuspending the cell pellet in fresh media at the desired density.

Western Blot for DVL3 Phosphorylation

This assay assesses the ability of **MU1742** to inhibit CK1δ/ε-mediated phosphorylation of Dishevelled 3 (DVL3), a key downstream component of the Wnt pathway. Phosphorylation of DVL3 leads to a characteristic mobility shift on an SDS-PAGE gel.

- Cell Seeding: Plate HEK293T cells in 6-well plates and grow to 70-80% confluency.
- Treatment: Treat cells with varying concentrations of **MU1742** (e.g., 0.1, 1, 10 μM) or DMSO as a vehicle control for 4-6 hours.
- Cell Lysis: Wash cells with ice-cold PBS and lyse in RIPA buffer supplemented with protease and phosphatase inhibitors.
- Protein Quantification: Determine protein concentration using a BCA assay.
- SDS-PAGE and Transfer: Separate 20-30 μg of protein lysate on an 8% SDS-PAGE gel and transfer to a PVDF membrane.
- Blocking: Block the membrane with 5% non-fat milk or BSA in TBST for 1 hour at room temperature.

- **Primary Antibody Incubation:** Incubate the membrane with a primary antibody against DVL3 overnight at 4°C.
- **Secondary Antibody Incubation:** Wash the membrane with TBST and incubate with an HRP-conjugated secondary antibody for 1 hour at room temperature.
- **Detection:** Visualize bands using an enhanced chemiluminescence (ECL) substrate.

TopFlash Reporter Assay

This luciferase-based assay quantifies the transcriptional activity of the Wnt/ β -catenin pathway. Inhibition of CK1 δ/ϵ by **MU1742** is expected to decrease Wnt-mediated signaling and thus reduce luciferase expression.

- **Cell Seeding:** Seed HEK293T cells in a 24-well plate.
- **Transfection:** Co-transfect cells with Super8X TopFlash and pRLTK (Renilla) luciferase reporter plasmids (0.1 μ g of each per well) using a suitable transfection reagent.^[6]
- **Treatment:** 24 hours post-transfection, treat cells with Wnt3a conditioned media (or a GSK-3 β inhibitor like CHIR99021 as a positive control for pathway activation) in the presence of varying concentrations of **MU1742** or DMSO.
- **Cell Lysis and Luciferase Assay:** After 16-24 hours of treatment, lyse the cells and measure both Firefly and Renilla luciferase activities using a dual-luciferase reporter assay system.
- **Data Analysis:** Normalize the Firefly luciferase activity to the Renilla luciferase activity to account for transfection efficiency. Express the results as a fold change relative to the vehicle control.

Trans-well Migration Assay

This assay evaluates the effect of **MU1742** on the migration of leukemic cells (e.g., JURKAT) towards a chemoattractant, such as CCL19.

- **Cell Preparation:** Resuspend JURKAT cells in serum-free RPMI-1640 medium at a concentration of 1×10^6 cells/mL. Pre-treat cells with different concentrations of **MU1742** or DMSO for 30 minutes at 37°C.

- Assay Setup: Add 600 μL of RPMI-1640 containing 100 ng/mL CCL19 to the lower chamber of a trans-well plate (5 μm pore size). Add 100 μL of the pre-treated cell suspension to the upper chamber.
- Incubation: Incubate the plate at 37°C in a 5% CO₂ incubator for 2-4 hours.
- Quantification: Count the number of cells that have migrated to the lower chamber using a hemocytometer or an automated cell counter.
- Data Analysis: Express the number of migrated cells as a percentage of the vehicle-treated control.

Alamar Blue Cytotoxicity Assay

This assay measures cell viability and proliferation. The data from this assay helps to distinguish between cytotoxic effects and specific pathway inhibition by **MU1742**.

- Cell Seeding: Seed HEK293 or JURKAT cells in a 96-well plate at a density of 5,000-10,000 cells per well.
- Treatment: The following day, treat the cells with a serial dilution of **MU1742** (e.g., 0.01 to 100 μM) or DMSO as a vehicle control.
- Incubation: Incubate the plate for 24 to 72 hours at 37°C in a 5% CO₂ incubator.
- Alamar Blue Addition: Add Alamar Blue reagent (10% of the culture volume) to each well and incubate for another 2-4 hours.
- Measurement: Measure the fluorescence (Excitation: 560 nm, Emission: 590 nm) or absorbance (570 nm) using a microplate reader.^[7]
- Data Analysis: Calculate cell viability as a percentage of the vehicle-treated control and determine the IC₅₀ value by plotting the viability against the log of the **MU1742** concentration.

Need Custom Synthesis?

BenchChem offers custom synthesis for rare earth carbides and specific isotopic labeling.

Email: info@benchchem.com or [Request Quote Online](#).

References

- 1. CASINVENT - SGC recommends the compound MU1742 as a new chemical probe for protein kinases CK1 δ and CK1 ϵ , developed in collaboration with the researchers of CasInvent Pharma, a.s. [casinvent.com]
- 2. MU1742 | Structural Genomics Consortium [thesgc.org]
- 3. eubopen.org [eubopen.org]
- 4. alamarBlue Assays for Cell Viability Protocol, for Microplates | Thermo Fisher Scientific - US [thermofisher.com]
- 5. Wnt Reporter Activity Assay [bio-protocol.org]
- 6. cdr.lib.unc.edu [cdr.lib.unc.edu]
- 7. bio-rad-antibodies.com [bio-rad-antibodies.com]
- To cite this document: BenchChem. [MU1742: Application Notes and Protocols for Cell-Based Assays]. BenchChem, [2026]. [Online PDF]. Available at: [<https://www.benchchem.com/product/b15544333/docs#mu1742-application-notes-and-protocols-for-cell-based-assays>]

Disclaimer & Data Validity:

The information provided in this document is for Research Use Only (RUO) and is strictly not intended for diagnostic or therapeutic procedures. While BenchChem strives to provide accurate protocols, we make no warranties, express or implied, regarding the fitness of this product for every specific experimental setup.

Technical Support: The protocols provided are for reference purposes. Unsure if this reagent suits your experiment?

Need Industrial/Bulk Grade? [Request Custom Synthesis Quote](#)

BenchChem

Our mission is to be the trusted global source of essential and advanced chemicals, empowering scientists and researchers to drive progress in science and industry.

Contact

Address: 3281 E Guasti Rd

Ontario, CA 91761, United States

Phone: (601) 213-4426

Email: info@benchchem.com

[Contact our Ph.D. Support Team for a compatibility check](#)