

# In-Depth Technical Guide: CK1-IN-4 Mechanism of Action

**Author:** BenchChem Technical Support Team. **Date:** April 2026

## Compound of Interest

Compound Name: CK1-IN-4  
Cat. No.: B15544170

[Get Quote](#)

For Researchers, Scientists, and Drug Development Professionals

This technical guide provides a comprehensive overview of the mechanism of action for the Casein Kinase 1 (CK1) inhibitor, **CK1-IN-4**. The information presented herein is intended to support research and drug development efforts by providing detailed data, experimental protocols, and visual representations of the inhibitor's biological context.

## Core Compound Properties

**CK1-IN-4**, also identified as Compound 59 in the work by Grieco et al. (2024), is a small molecule inhibitor belonging to the 7-amino-[1][2][3]triazolo[1,5-a][1][4][5]triazine chemical class.[1][2] It has been characterized as an ATP-competitive inhibitor of Casein Kinase 1 delta (CK1δ).[1][6]

## Quantitative Data

The inhibitory activity of **CK1-IN-4** has been primarily characterized against CK1δ. A comprehensive kinase selectivity profile against a broader panel of kinases is not yet publicly available.

Target	Parameter	Value	Reference
CK1δ	IC50	2.74 μM	[1]

Note: The IC50 value represents the concentration of **CK1-IN-4** required to inhibit 50% of the enzymatic activity of CK1δ in a biochemical assay. Further studies are required to determine the inhibitor's selectivity against other CK1 isoforms (α, ε, γ) and a wider range of protein kinases.

## Mechanism of Action and Signaling Pathways

**CK1-IN-4** exerts its effects by inhibiting the catalytic activity of CK1δ, a key serine/threonine kinase involved in the regulation of multiple critical cellular signaling pathways.[1][7][8] By blocking the ATP-binding pocket of CK1δ, **CK1-IN-4** prevents the phosphorylation of downstream substrates, thereby modulating the activity of these pathways.[2]

### Wnt/β-catenin Signaling Pathway

CK1δ plays a crucial, albeit complex, role in the Wnt/β-catenin signaling pathway. In the absence of a Wnt ligand, CK1δ, in concert with Glycogen Synthase Kinase 3 (GSK3), phosphorylates β-catenin, targeting it for ubiquitination and subsequent proteasomal degradation.[5][7] Inhibition of CK1δ by **CK1-IN-4** is expected to disrupt this process, leading to the stabilization and accumulation of β-catenin. This, in turn, would allow β-catenin to translocate to the nucleus and activate the transcription of TCF/LEF target genes.

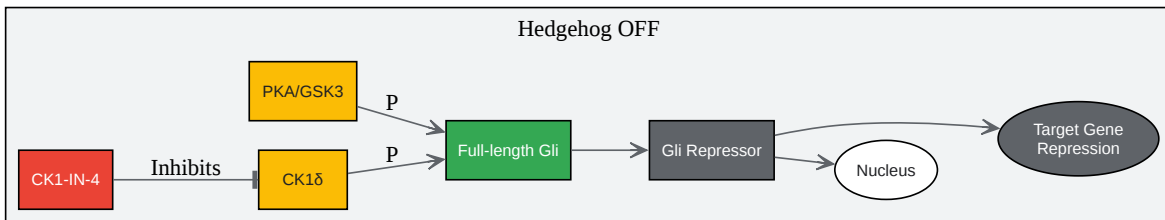
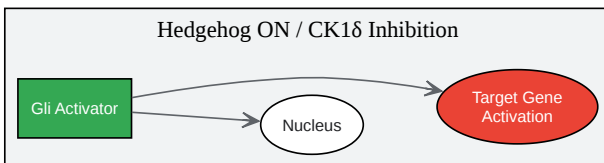
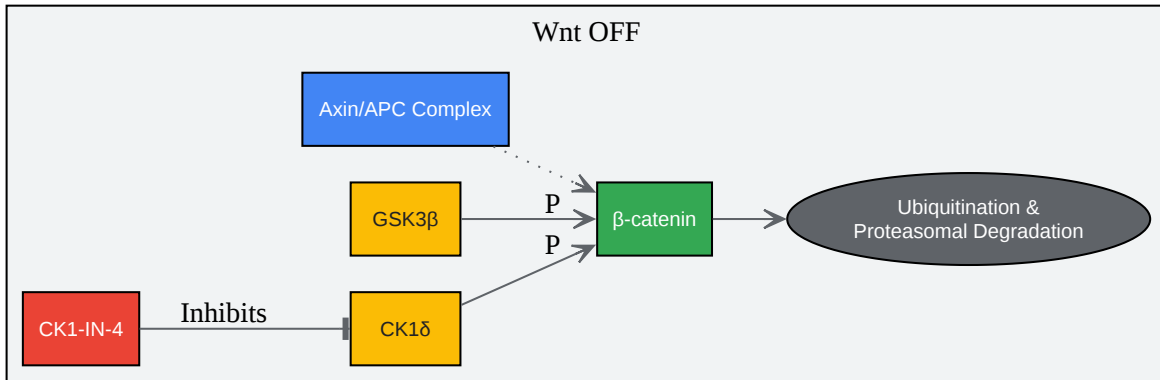
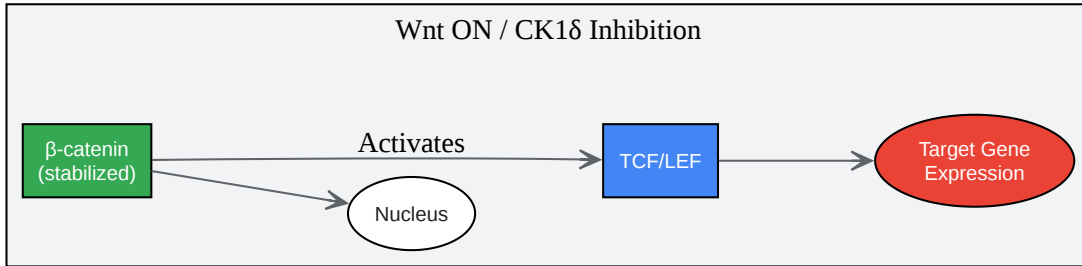

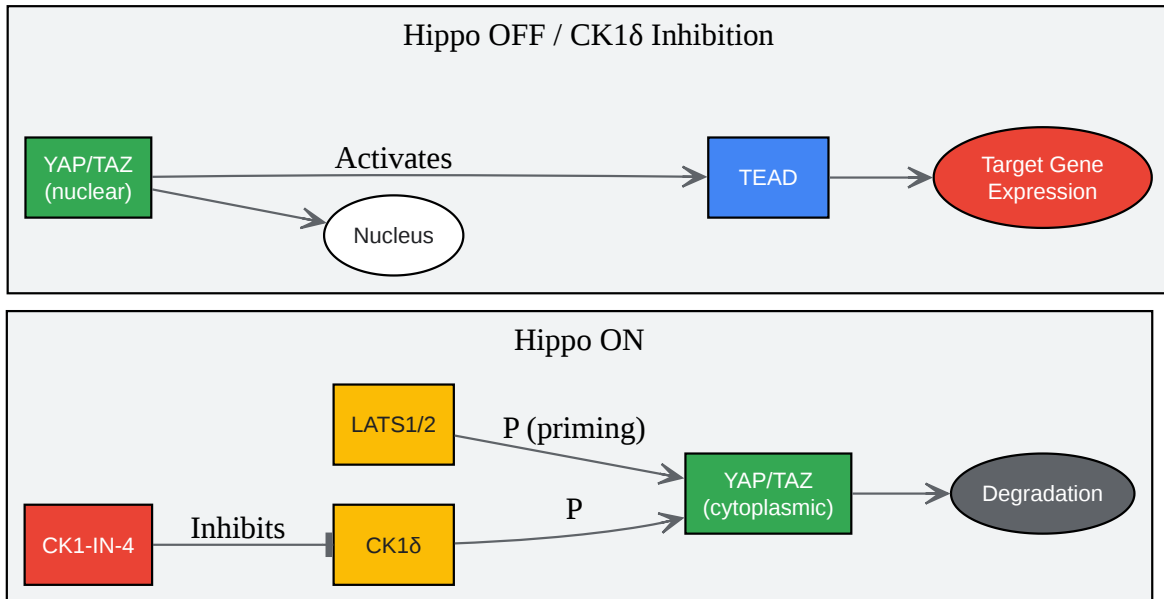

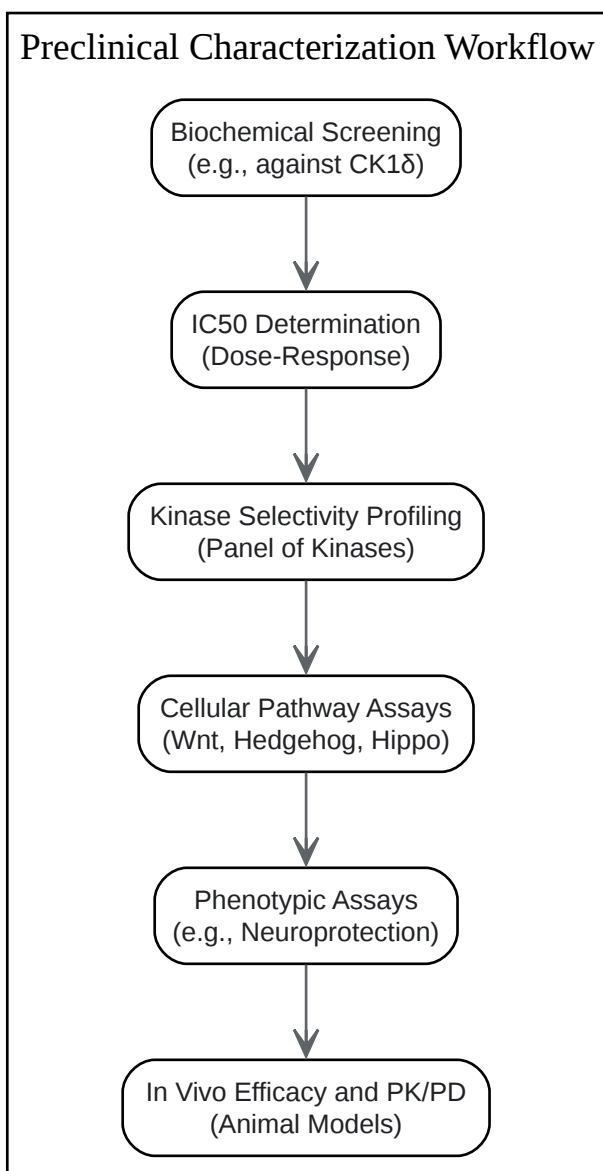

[Click to download full resolution via product page](#)

### Need Custom Synthesis?

BenchChem offers custom synthesis for rare earth carbides and specific isotopic labeling.

Email: [info@benchchem.com](mailto:info@benchchem.com) or [Request Quote Online](#).

## References

- 1. [promega.jp](#) [[promega.jp](#)]

- [2. Assessing the Inhibitory Potential of Kinase Inhibitors In Vitro: Major Pitfalls and Suggestions for Improving Comparability of Data Using CK1 Inhibitors as an Example - PMC \[pmc.ncbi.nlm.nih.gov\]](#)
- [3. Gli Phosphorylation Code in Hedgehog Signal Transduction - PMC \[pmc.ncbi.nlm.nih.gov\]](#)
- [4. researchgate.net \[researchgate.net\]](#)
- [5. A Computational Workflow for the Identification of Novel Fragments Acting as Inhibitors of the Activity of Protein Kinase CK1 \$\delta\$  - PubMed \[pubmed.ncbi.nlm.nih.gov\]](#)
- [6. benchchem.com \[benchchem.com\]](#)
- [7. CK1 in Developmental signaling: Hedgehog and Wnt - PMC \[pmc.ncbi.nlm.nih.gov\]](#)
- [8. discovery.dundee.ac.uk \[discovery.dundee.ac.uk\]](#)
- To cite this document: BenchChem. [In-Depth Technical Guide: CK1-IN-4 Mechanism of Action]. BenchChem, [2026]. [Online PDF]. Available at: [\[https://www.benchchem.com/product/b15544170/docs#in-depth-technical-guide-ck1-in-4-mechanism-of-action\]](https://www.benchchem.com/product/b15544170/docs#in-depth-technical-guide-ck1-in-4-mechanism-of-action)

---

### Disclaimer & Data Validity:

The information provided in this document is for Research Use Only (RUO) and is strictly not intended for diagnostic or therapeutic procedures. While BenchChem strives to provide accurate protocols, we make no warranties, express or implied, regarding the fitness of this product for every specific experimental setup.

**Technical Support:** The protocols provided are for reference purposes. Unsure if this reagent suits your experiment?

**Need Industrial/Bulk Grade?** [Request Custom Synthesis Quote](#)

## BenchChem

Our mission is to be the trusted global source of essential and advanced chemicals, empowering scientists and researchers to drive progress in science and industry.

### Contact

Address: 3281 E Guasti Rd  
Ontario, CA 91761, United States  
Phone: (601) 213-4426  
Email: [info@benchchem.com](mailto:info@benchchem.com)

Contact our Ph.D. Support Team for a compatibility check