

Application Notes and Protocols for the BE-13 Cell Line

Author: BenchChem Technical Support Team. **Date:** April 2026

Compound of Interest

Compound Name: *BY13*
Cat. No.: *B15544700*

[Get Quote](#)

Caution: The BE-13 cell line (Cellosaurus identifier: CVCL_1081) is reported as being a derivative of the Peer cell line and is listed as a misidentified or contaminated cell line.^[1] Researchers should exercise caution and verify the identity of their cell stocks, for example, through Short Tandem Repeat (STR) profiling.^[1] The following protocols are based on general procedures for human T-cell leukemia cell lines and should be adapted as necessary.

Cell Line Characteristics

The BE-13 cell line was originally thought to be derived from the bone marrow of an 11-year-old patient with T-cell acute lymphoblastic leukemia (T-ALL).^[1] However, it has since been identified as a derivative of the Peer cell line.^[1] It is a human T-cell line from a female donor, sampled at the age of four.^[1] These cells exhibit characteristics of both prothymocytes and thymocytes.^[1] A notable genetic feature of this cell line is a mutation in the NOTCH1 gene (p.Leu1600Pro) and a NUP214-ABL1 gene fusion.^[1] The BE-13 cell line is known to be highly sensitive to dexamethasone-induced cytolysis.^[1]

Parameter	Value	Source
Cell Type	T-cell	[1]
Species	Homo sapiens (Human)	[1]
Age at Sampling	4 Years	[1]
Gender	Female	[1]
Disease	T-cell acute lymphoblastic leukemia (T-ALL)	[1]
Doubling Time	Approximately 40-60 hours	[1]
Culture Type	Suspension	[2]

Experimental Protocols

Media and Reagents

Reagent	Specification
Growth Medium	RPMI 1640
Serum	Fetal Bovine Serum (FBS), heat-inactivated
Supplements	L-glutamine, Penicillin-Streptomycin
Cryopreservation Medium	90% FBS, 10% DMSO
Dissociation Agent	Not applicable (suspension cells)
Buffer	Phosphate-Buffered Saline (PBS), Ca ²⁺ /Mg ²⁺ free

General Cell Culture Conditions

Successful cell culture requires maintaining a sterile environment and providing suitable conditions for cell growth.[3] Most mammalian cell lines, including leukemia cell lines, are cultured at 37°C in a humidified incubator with 5% CO₂. [3][4] The pH of the growth medium should be maintained between 7.2 and 7.4 for optimal growth.[3]

Parameter	Recommended Condition
Temperature	37°C
CO2 Concentration	5%
Humidity	>95%

Protocol 1: Thawing of Cryopreserved Cells

This protocol outlines the steps for reviving frozen BE-13 cells.

- Pre-warm complete growth medium (RPMI 1640 with 10% FBS, L-glutamine, and Penicillin-Streptomycin) in a 37°C water bath.[5]
- Remove the cryovial from liquid nitrogen storage.
- Partially immerse the vial in the 37°C water bath to thaw the cells rapidly. Do not submerge the cap to avoid contamination.[6]
- Once a small ice crystal remains, remove the vial from the water bath.[6]
- Wipe the exterior of the vial with 70% ethanol before opening in a laminar flow hood.[5]
- Using a sterile pipette, gently transfer the cell suspension into a 15 mL conical tube containing 9 mL of pre-warmed complete growth medium.
- Centrifuge the cell suspension at 200 x g for 5 minutes to pellet the cells.[5]
- Aspirate the supernatant, which contains residual cryoprotectant (DMSO).
- Gently resuspend the cell pellet in 5-10 mL of fresh, pre-warmed complete growth medium.
- Transfer the cell suspension to a T-25 or T-75 culture flask.
- Incubate at 37°C with 5% CO2.

Protocol 2: Routine Maintenance and Passaging of Suspension Cells

BE-13 cells grow in suspension and require routine passaging to maintain viability and logarithmic growth.

- Aseptically remove an aliquot of the cell suspension from the culture flask.
- Perform a cell count using a hemocytometer or an automated cell counter. A viability stain, such as trypan blue, can be used to distinguish live from dead cells.[7]
- Calculate the volume of the cell suspension needed to seed a new flask at the desired density (e.g., 2×10^5 cells/mL).
- Add the calculated volume of cell suspension to a new culture flask.
- Add fresh, pre-warmed complete growth medium to reach the desired final volume.
- Incubate at 37°C with 5% CO₂.
- Depending on the growth rate, cells should be passaged every 2-3 days.

Protocol 3: Cryopreservation of Cells

This protocol describes how to freeze BE-13 cells for long-term storage.

- Use cells from a healthy, log-phase culture.
- Perform a cell count to determine the cell density.
- Centrifuge the required volume of cell suspension at 200 x g for 5 minutes.
- Aspirate the supernatant and resuspend the cell pellet in cold cryopreservation medium (90% FBS, 10% DMSO) at a concentration of $1-5 \times 10^6$ cells/mL.[5]
- Aliquot the cell suspension into sterile cryovials.

- Place the vials in a controlled-rate freezing container (e.g., "Mr. Frosty") and store at -80°C for at least 24 hours.^[5] This allows for a slow cooling rate of approximately -1°C per minute.
- Transfer the vials to a liquid nitrogen freezer for long-term storage.

Signaling Pathways and Experimental Workflows

NOTCH1 Signaling Pathway in T-ALL

The NOTCH1 signaling pathway is frequently mutated in T-ALL, leading to aberrant cell proliferation and survival. The following diagram illustrates a simplified representation of this pathway.

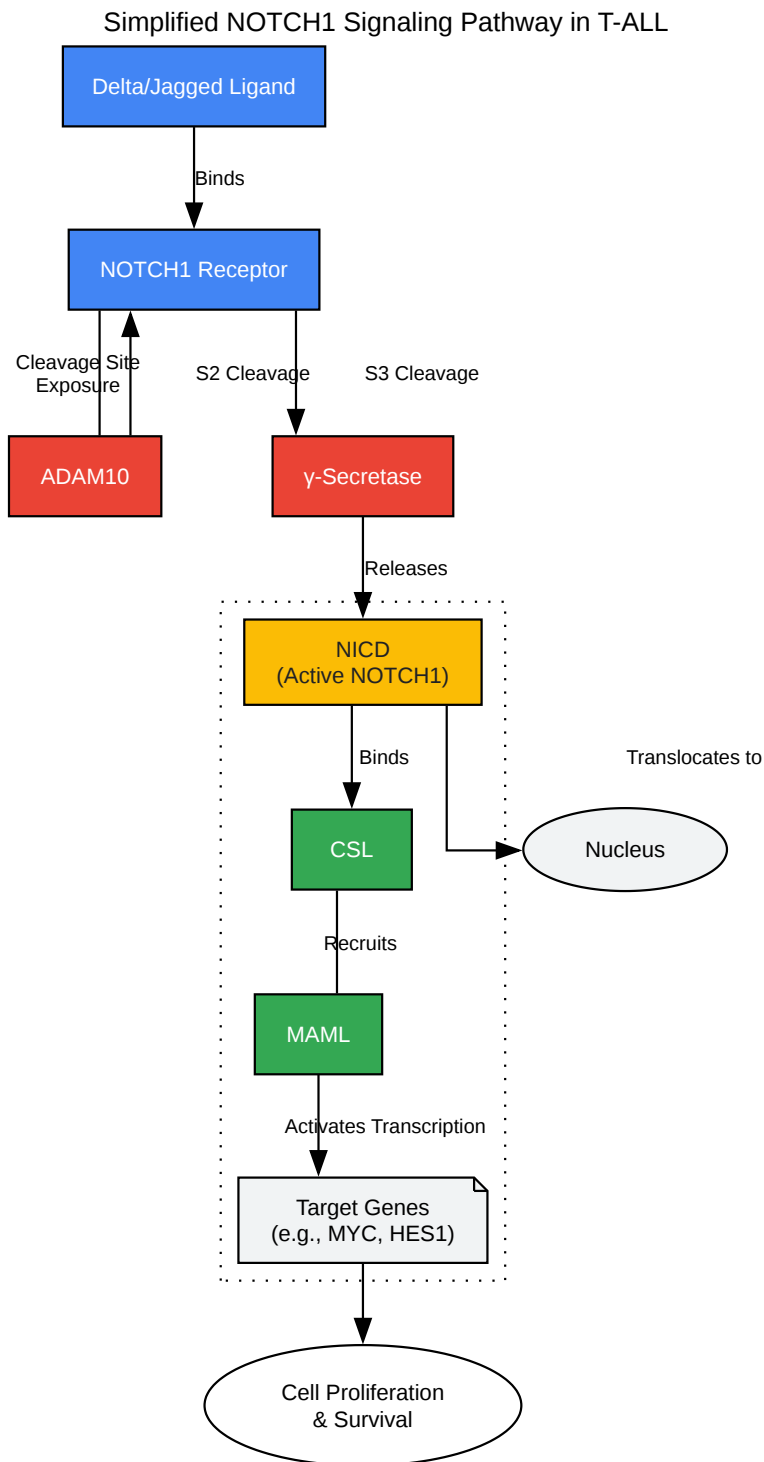

[Click to download full resolution via product page](#)

Caption: Simplified NOTCH1 signaling pathway in T-ALL.

Experimental Workflow for Cell Passaging

The following diagram illustrates the general workflow for subculturing suspension cells like BE-13.

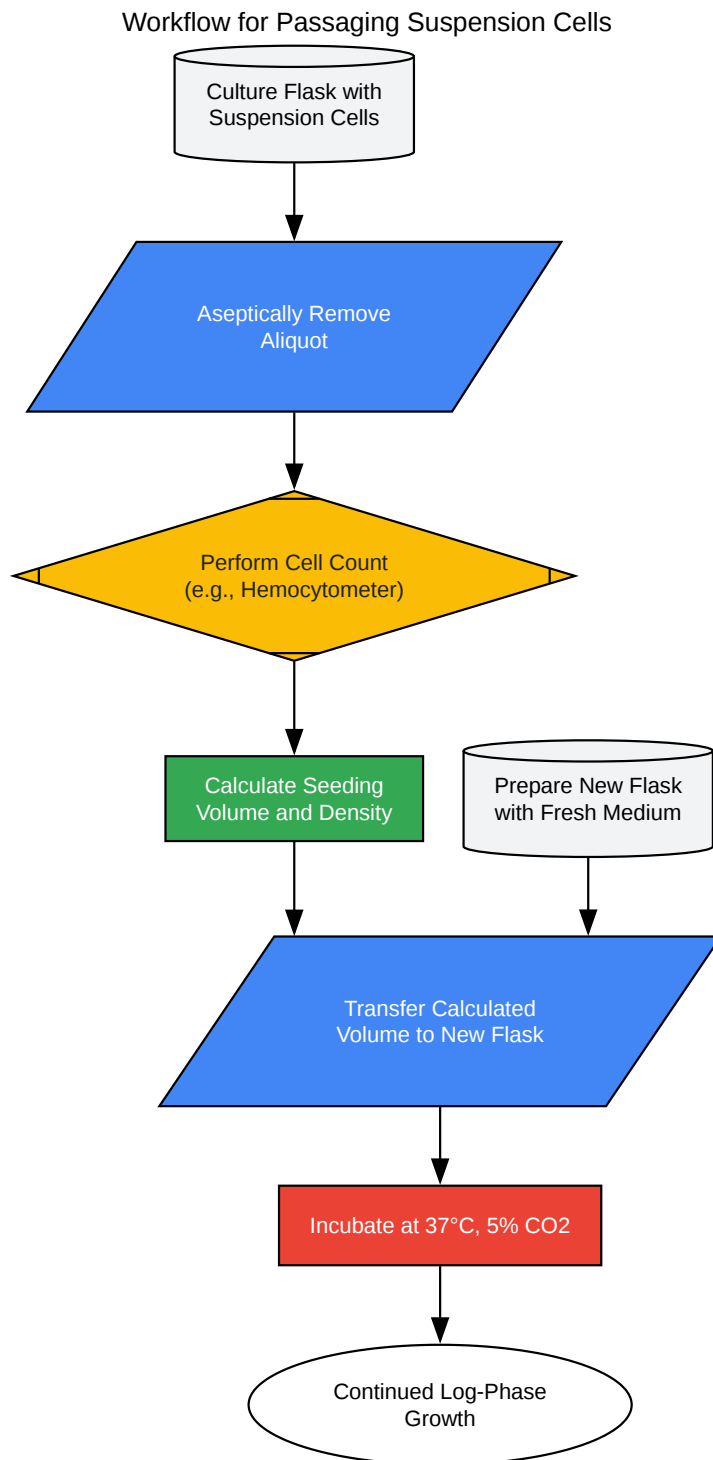

[Click to download full resolution via product page](#)

Caption: Workflow for passaging suspension cells.

Need Custom Synthesis?

BenchChem offers custom synthesis for rare earth carbides and specific isotopic labeling.

Email: info@benchchem.com or [Request Quote Online](#).

References

- [1. Cellosaurus cell line BE-13 \(CVCL_1081\) \[cellosaurus.org\]](#)
- [2. Cell Types & Culture Characteristics \[sigmaaldrich.com\]](#)
- [3. What Are the 4 Requirements for Cell Culture \[fdcell.com\]](#)
- [4. Cell culture conditions \[qiagen.com\]](#)
- [5. bio.libretexts.org \[bio.libretexts.org\]](#)
- [6. editxor.com \[editxor.com\]](#)
- [7. Cell Culture Protocols | Thermo Fisher Scientific - JP \[thermofisher.com\]](#)
- To cite this document: BenchChem. [Application Notes and Protocols for the BE-13 Cell Line]. BenchChem, [2026]. [Online PDF]. Available at: [\[https://www.benchchem.com/product/b15544700/docs#application-notes-and-protocols-for-the-be-13-cell-line\]](https://www.benchchem.com/product/b15544700/docs#application-notes-and-protocols-for-the-be-13-cell-line)

Disclaimer & Data Validity:

The information provided in this document is for Research Use Only (RUO) and is strictly not intended for diagnostic or therapeutic procedures. While BenchChem strives to provide accurate protocols, we make no warranties, express or implied, regarding the fitness of this product for every specific experimental setup.

Technical Support: The protocols provided are for reference purposes. Unsure if this reagent suits your experiment?

Need Industrial/Bulk Grade? [Request Custom Synthesis Quote](#)

BenchChem

Our mission is to be the trusted global source of essential and advanced chemicals, empowering scientists and researchers to drive progress in science and industry.

Contact

Address: 3281 E Guasti Rd
Ontario, CA 91761, United States
Phone: (601) 213-4426
Email: info@benchchem.com

[Contact our Ph.D. Support Team for a compatibility check](#)