

Application Notes and Protocols for YX968 in MDA-MB-231 Cells

Author: BenchChem Technical Support Team. **Date:** April 2026

Compound of Interest

Compound Name: YX968
Cat. No.: B15544573

[Get Quote](#)

For Researchers, Scientists, and Drug Development Professionals

These application notes provide a comprehensive overview and detailed experimental protocols for the use of **YX968**, a potent and selective dual degrader of histone deacetylase 3 (HDAC3) and histone deacetylase 8 (HDAC8), in the context of the triple-negative breast cancer cell line, MDA-MB-231. **YX968** induces degradation of its target proteins through the ubiquitin-proteasome system, leading to the suppression of cancer cell growth and the induction of apoptosis.^{[1][2][3]}

Mechanism of Action

YX968 is a proteolysis-targeting chimera (PROTAC) that selectively and rapidly degrades HDAC3 and HDAC8.^{[2][3]} This targeted degradation leads to a potent anti-proliferative effect in various cancer cell lines, including MDA-MB-231.^[1] The mechanism of action involves the recruitment of the VHL E3 ligase to the target proteins, leading to their ubiquitination and subsequent degradation by the proteasome.^[1] **YX968** has been shown to induce G1 cell cycle arrest and promote apoptosis, as evidenced by the activation of caspase-3.^{[1][4]}

Data Summary

The following tables summarize the quantitative data regarding the efficacy and activity of **YX968** in MDA-MB-231 cells.

Table 1: Degradation Efficiency of **YX968** in MDA-MB-231 Cells

Target Protein	DC50 (8h treatment)	Reference
HDAC3	1.7 nM	[5]
HDAC8	6.1 nM	[1][5]

Table 2: Anti-proliferative and Apoptotic Effects of **YX968** on MDA-MB-231 Cells

Assay	Concentration	Incubation Time	Observed Effect	Reference
Colony Formation Assay	Sub- μ M	Not Specified	Effective suppression of growth	[1]
Cell Cycle Analysis	1 μ M	24 h	Strong G1 arrest	[1]
Caspase-3 Activation	0.063 - 64 μ M	16 h	Dose-dependent increase in CASP3 cleavage	[4]

Experimental Protocols

Herein are detailed protocols for key experiments to assess the effect of **YX968** on MDA-MB-231 cells.

Protocol 1: Cell Culture and Maintenance

- Cell Line: MDA-MB-231 (human breast adenocarcinoma).
- Culture Medium: Dulbecco's Modified Eagle's Medium (DMEM) supplemented with 10% Fetal Bovine Serum (FBS) and 1% Penicillin-Streptomycin.

- Culture Conditions: Maintain cells in a humidified incubator at 37°C with 5% CO₂.
- Subculturing: Passage cells every 2-3 days or when they reach 80-90% confluency.

Protocol 2: Colony Formation Assay

- Seeding: Seed MDA-MB-231 cells in 6-well plates at a density of 500-1000 cells per well.
- Treatment: After 24 hours, treat the cells with varying concentrations of **YX968** (e.g., 0.1 μM to 10 μM) or DMSO as a vehicle control.
- Incubation: Incubate the plates for 10-14 days, replacing the medium with fresh medium containing the respective treatments every 3-4 days.
- Staining: After the incubation period, wash the colonies with PBS, fix with methanol for 15 minutes, and stain with 0.5% crystal violet solution for 30 minutes.
- Quantification: Wash the plates with water, air dry, and count the number of colonies (containing >50 cells).

Protocol 3: Western Blot Analysis for Protein Degradation and Apoptosis

- Cell Lysis: Plate MDA-MB-231 cells and treat with desired concentrations of **YX968** for the indicated times (e.g., 8 hours for degradation, 16 hours for apoptosis). Lyse the cells in RIPA buffer containing protease and phosphatase inhibitors.
- Protein Quantification: Determine the protein concentration of the lysates using a BCA protein assay.
- SDS-PAGE and Transfer: Separate equal amounts of protein (20-30 μg) on an SDS-polyacrylamide gel and transfer to a PVDF membrane.
- Immunoblotting: Block the membrane with 5% non-fat milk or BSA in TBST for 1 hour at room temperature. Incubate the membrane with primary antibodies against HDAC3, HDAC8, cleaved caspase-3, and a loading control (e.g., GAPDH or β-actin) overnight at 4°C.

- Detection: Wash the membrane with TBST and incubate with the appropriate HRP-conjugated secondary antibody for 1 hour at room temperature. Visualize the protein bands using an enhanced chemiluminescence (ECL) detection system.

Protocol 4: Cell Cycle Analysis by Flow Cytometry

- Cell Treatment: Seed MDA-MB-231 cells and treat with **YX968** (e.g., 1 μ M) or DMSO for 24 hours.
- Cell Harvesting and Fixation: Harvest the cells by trypsinization, wash with PBS, and fix in cold 70% ethanol overnight at -20°C.
- Staining: Wash the fixed cells with PBS and resuspend in a staining solution containing propidium iodide (PI) and RNase A.
- Flow Cytometry: Analyze the cell cycle distribution using a flow cytometer.

Visualizations

The following diagrams illustrate the mechanism of action of **YX968** and a typical experimental workflow.

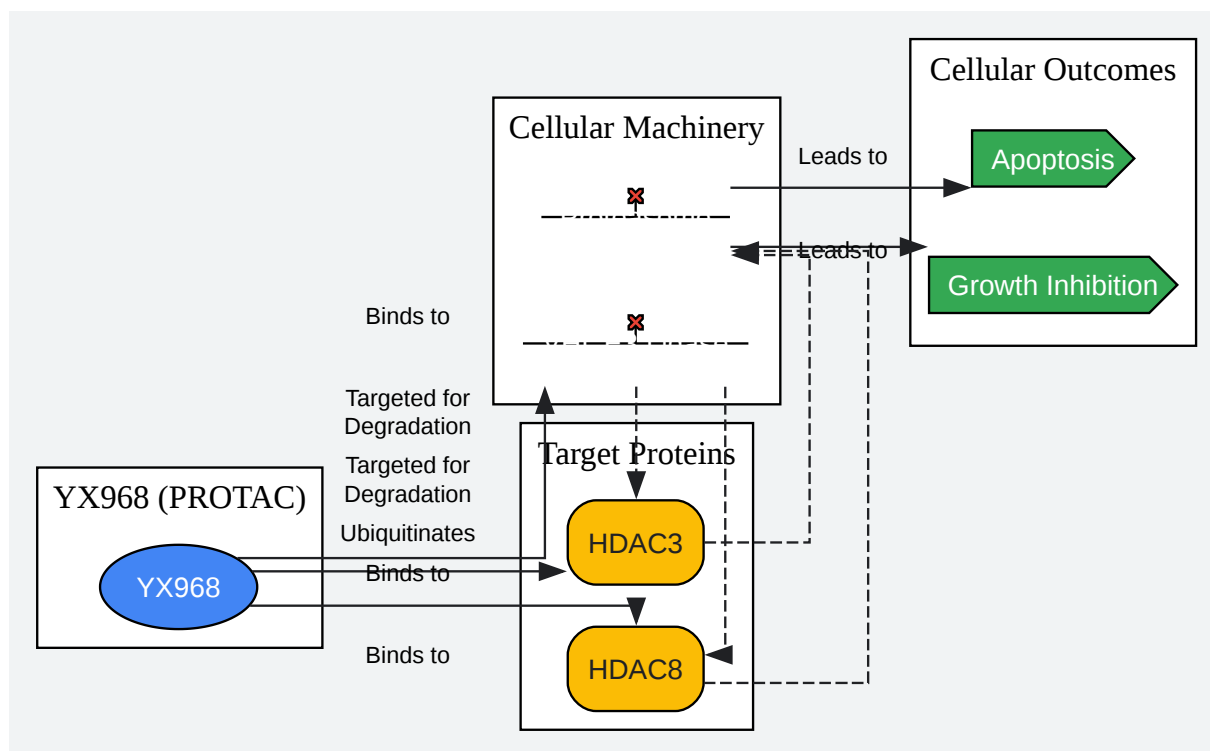

[Click to download full resolution via product page](#)

Caption: Mechanism of action of **YX968** as an HDAC3/8 PROTAC degrader.

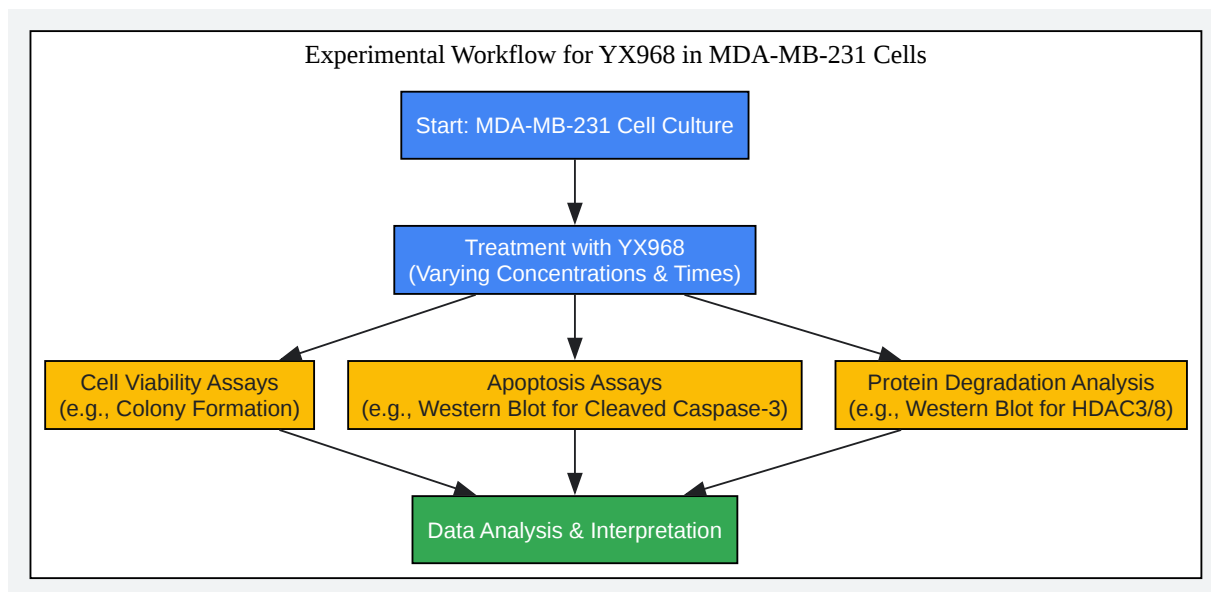

[Click to download full resolution via product page](#)

Caption: A typical experimental workflow for evaluating **YX968**.

Need Custom Synthesis?

BenchChem offers custom synthesis for rare earth carbides and specific isotopic labeling.

Email: info@benchchem.com or [Request Quote Online](#).

References

- 1. HDAC3 and HDAC8 PROTAC dual degrader reveals roles of histone acetylation in gene regulation - PMC [[pmc.ncbi.nlm.nih.gov](https://pubmed.ncbi.nlm.nih.gov/)]
- 2. HDAC3 and HDAC8 PROTAC dual degrader reveals roles of histone acetylation in gene regulation - PubMed [pubmed.ncbi.nlm.nih.gov]
- 3. [selleckchem.com](https://www.selleckchem.com) [[selleckchem.com](https://www.selleckchem.com)]
- 4. [medchemexpress.com](https://www.medchemexpress.com) [[medchemexpress.com](https://www.medchemexpress.com)]

- [5. YX968 | HDAC3/8 PROTAC | Probechem Biochemicals \[probechem.com\]](#)
- To cite this document: BenchChem. [Application Notes and Protocols for YX968 in MDA-MB-231 Cells]. BenchChem, [2026]. [Online PDF]. Available at: [<https://www.benchchem.com/product/b15544573/docs#application-notes-and-protocols-for-yx968-in-mda-mb-231-cells>]

Disclaimer & Data Validity:

The information provided in this document is for Research Use Only (RUO) and is strictly not intended for diagnostic or therapeutic procedures. While BenchChem strives to provide accurate protocols, we make no warranties, express or implied, regarding the fitness of this product for every specific experimental setup.

Technical Support: The protocols provided are for reference purposes. Unsure if this reagent suits your experiment?

Need Industrial/Bulk Grade? [Request Custom Synthesis Quote](#)

BenchChem

Our mission is to be the trusted global source of essential and advanced chemicals, empowering scientists and researchers to drive progress in science and industry.

Contact

Address: 3281 E Guasti Rd
Ontario, CA 91761, United States
Phone: (601) 213-4426
Email: info@benchchem.com

[Contact our Ph.D. Support Team for a compatibility check](#)