

Application Notes and Protocols: TCO-PEG24-Acid for Proteomic Sample Preparation

Author: BenchChem Technical Support Team. **Date:** April 2026

Compound of Interest

Compound Name: TCO-PEG24-acid

Cat. No.: B15544463

[Get Quote](#)

For Researchers, Scientists, and Drug Development Professionals

This document provides detailed application notes and protocols for the use of **TCO-PEG24-acid** in proteomic sample preparation. **TCO-PEG24-acid** is a versatile chemical tool that enables the efficient labeling and enrichment of proteins from complex biological samples through bioorthogonal click chemistry.

Introduction

TCO-PEG24-acid is a chemical probe containing a trans-cyclooctene (TCO) moiety, a hydrophilic 24-unit polyethylene glycol (PEG) spacer, and a terminal carboxylic acid. The TCO group reacts with exceptional speed and specificity with a tetrazine-functionalized molecule in a bioorthogonal inverse-electron-demand Diels-Alder cycloaddition (IEDDA) reaction.[1][2] This "click chemistry" reaction is highly efficient and proceeds rapidly under biocompatible conditions without the need for a toxic copper catalyst.[2][3]

The PEG spacer enhances the solubility of the reagent and the labeled proteins in aqueous buffers, reduces aggregation, and minimizes steric hindrance.[4][5] The terminal carboxylic acid allows for the covalent attachment of the TCO-PEG24 moiety to primary amines (e.g., lysine residues) on proteins after activation.

This technology is a powerful tool for a variety of proteomic applications, including:

- Activity-Based Protein Profiling (ABPP): To identify and quantify the active members of entire enzyme families.[\[6\]](#)[\[7\]](#)[\[8\]](#)[\[9\]](#)
- Target Identification and Validation: To enrich and identify the protein targets of small molecule drugs or probes.[\[1\]](#)[\[10\]](#)
- Analysis of Protein-Protein Interactions: To capture and identify protein interaction partners.
- Post-Translational Modification Studies: To enrich and analyze proteins with specific modifications.

Quantitative Data

The TCO-tetrazine ligation has demonstrated superior performance in proteomic applications compared to other click chemistry methods.

Parameter	TCO-Tetrazine (iEDDA)	SPAAC (e.g., DBCO-Azide)	CuAAC (Copper-Catalyzed)	Reference
Reaction Rate	Extremely Fast (up to 10^6 $M^{-1}s^{-1}$)	Fast	Moderate	[1] [2]
Enrichment Efficiency (PARP1)	100%	45%	9%	[1]
Proteome Binding to Beads	96%	Not Reported	Not Reported	[11]
Biocompatibility	Excellent (catalyst-free)	Excellent (catalyst-free)	Lower (requires cytotoxic copper catalyst)	[2] [3]

Experimental Protocols

Here we provide detailed protocols for the use of **TCO-PEG24-acid** in proteomic sample preparation, from cell lysis to preparation for mass spectrometry analysis.

Protocol 1: Preparation of Cell Lysate

This protocol describes the preparation of a total protein lysate from cultured mammalian cells.

Materials:

- Cultured mammalian cells
- Phosphate-buffered saline (PBS), ice-cold
- Lysis Buffer (e.g., RIPA buffer) supplemented with protease and phosphatase inhibitors
- Cell scraper
- Microcentrifuge

Procedure:

- Wash cultured cells with ice-cold PBS.
- Add ice-cold Lysis Buffer to the cells.
- Scrape the cells and transfer the lysate to a pre-chilled microcentrifuge tube.
- Incubate on ice for 30 minutes with periodic vortexing.
- Centrifuge at 14,000 x g for 15 minutes at 4°C to pellet cell debris.
- Transfer the supernatant (protein lysate) to a new pre-chilled tube.
- Determine the protein concentration using a standard protein assay (e.g., BCA assay).

Protocol 2: Protein Labeling with **TCO-PEG24-Acid**

This protocol details the activation of **TCO-PEG24-acid** and its conjugation to proteins in the cell lysate.

Materials:

- Protein Lysate (from Protocol 1)
- **TCO-PEG24-acid**
- N-hydroxysuccinimide (NHS)
- 1-Ethyl-3-(3-dimethylaminopropyl)carbodiimide (EDC)
- Amine-free buffer (e.g., 100 mM sodium phosphate, 150 mM NaCl, pH 7.5)
- Quenching Buffer (e.g., 1 M Tris-HCl, pH 8.0)
- Desalting column

Procedure:

- Activation of **TCO-PEG24-acid**:
 - Dissolve **TCO-PEG24-acid**, NHS, and EDC in an amine-free buffer to prepare a stock solution of activated TCO-PEG24-NHS ester. A 1:1.2:1.2 molar ratio of acid:NHS:EDC is recommended.
- Protein Labeling:
 - Adjust the protein lysate concentration to 1-5 mg/mL with amine-free buffer.
 - Add a 20-fold molar excess of the activated TCO-PEG24-NHS ester solution to the protein sample.[\[4\]](#)
 - Incubate for 1 hour at room temperature with gentle mixing.[\[4\]](#)
- Quenching:
 - Stop the reaction by adding Quenching Buffer to a final concentration of 50-100 mM.[\[12\]](#)
 - Incubate for 5-10 minutes at room temperature.[\[12\]](#)

- Purification:
 - Remove excess, unreacted **TCO-PEG24-acid** and other small molecules using a desalting column equilibrated with an appropriate buffer (e.g., PBS).

Protocol 3: Enrichment of TCO-Labeled Proteins

This protocol describes the enrichment of TCO-labeled proteins using tetrazine-functionalized magnetic beads.

Materials:

- TCO-labeled protein lysate (from Protocol 2)
- Tetrazine-functionalized magnetic beads
- Wash Buffer 1 (e.g., PBS with 0.1% Tween-20)
- Wash Buffer 2 (e.g., PBS)
- Elution Buffer (e.g., 100 mM formic acid)[[11](#)]
- Magnetic rack

Procedure:

- Equilibrate the tetrazine-functionalized magnetic beads with Wash Buffer 1.
- Add the TCO-labeled protein lysate to the equilibrated beads.
- Incubate for 1-2 hours at room temperature with gentle rotation to allow for the click reaction to occur.
- Place the tube on a magnetic rack to capture the beads. Discard the supernatant.
- Wash the beads three times with Wash Buffer 1.
- Wash the beads two times with Wash Buffer 2 to remove detergents.

- Elution:
 - Add Elution Buffer to the beads and incubate for 15 minutes at room temperature with gentle rotation to release the captured proteins.[11]
 - Place the tube on the magnetic rack and collect the supernatant containing the enriched proteins.

Protocol 4: On-Bead Digestion for Mass Spectrometry

For proteomic analysis by mass spectrometry, proteins can be digested into peptides while still bound to the magnetic beads.

Materials:

- Protein-bound magnetic beads (from Protocol 3, before elution)
- Reduction Buffer (e.g., 10 mM DTT in 50 mM ammonium bicarbonate)
- Alkylation Buffer (e.g., 55 mM iodoacetamide in 50 mM ammonium bicarbonate)
- Trypsin solution (e.g., 20 µg/mL in 50 mM ammonium bicarbonate)
- Formic acid

Procedure:

- Reduction: Resuspend the protein-bound beads in Reduction Buffer and incubate for 30 minutes at 56°C.
- Alkylation: Cool to room temperature and add Alkylation Buffer. Incubate for 20 minutes in the dark.
- Digestion:
 - Wash the beads with 50 mM ammonium bicarbonate.
 - Resuspend the beads in Trypsin solution.

- Incubate overnight at 37°C with shaking.
- Peptide Collection:
 - Centrifuge the beads and collect the supernatant containing the digested peptides.
 - Acidify the peptide solution with formic acid to a final concentration of 0.1-1% to stop the digestion.
- The peptides are now ready for desalting (e.g., using C18 spin tips) and analysis by LC-MS/MS.

Visualizations

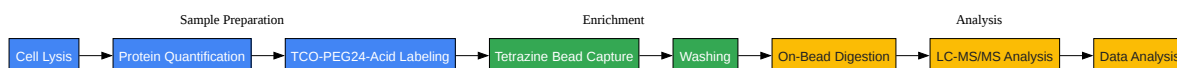

[Click to download full resolution via product page](#)

Figure 1. Experimental workflow for proteomic sample preparation using **TCO-PEG24-acid**.

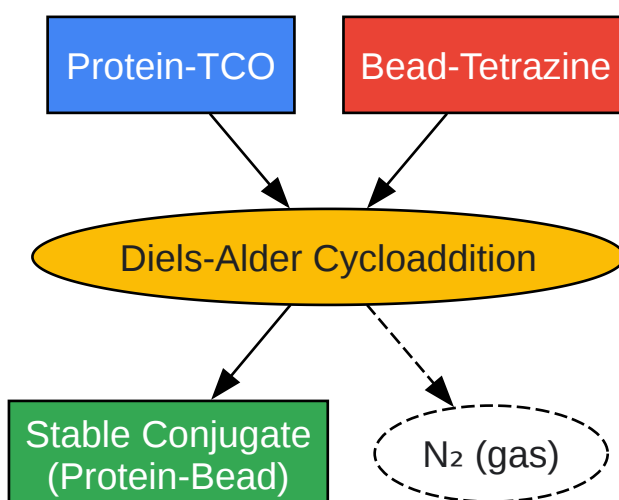

[Click to download full resolution via product page](#)

Figure 2. Bioorthogonal TCO-tetrazine ligation reaction.

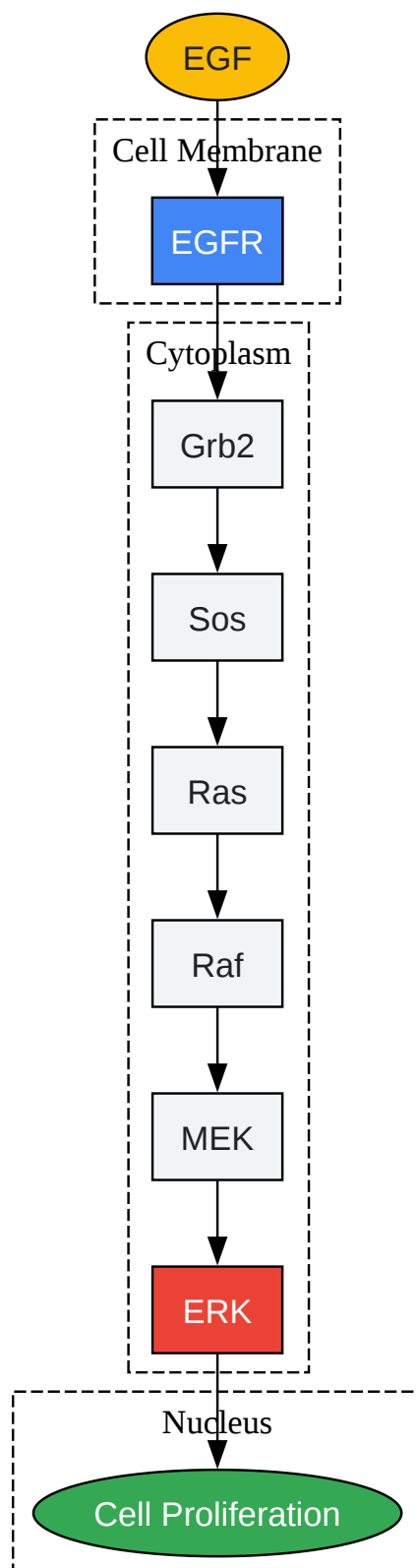

[Click to download full resolution via product page](#)

Figure 3. Simplified EGFR signaling pathway, a target for chemical proteomics.

Need Custom Synthesis?

BenchChem offers custom synthesis for rare earth carbides and specific isotopic labeling.

Email: info@benchchem.com or [Request Quote Online](#).

References

- 1. Tetrazine ligation for chemical proteomics - PMC [[pmc.ncbi.nlm.nih.gov](https://pubmed.ncbi.nlm.nih.gov/)]
- 2. broadpharm.com [broadpharm.com]
- 3. benchchem.com [benchchem.com]
- 4. interchim.fr [interchim.fr]
- 5. TCO PEG, TCO Linker - Click Chemistry Tools | AxisPharm [axispharm.com]
- 6. mdpi.com [mdpi.com]
- 7. Activity-Based Protein Profiling (ABPP) and Click Chemistry (CC)-ABPP by MudPIT Mass Spectrometry - PMC [[pmc.ncbi.nlm.nih.gov](https://pubmed.ncbi.nlm.nih.gov/)]
- 8. Activity-based protein profiling: applications to biomarker discovery, in vivo imaging and drug discovery - PubMed [pubmed.ncbi.nlm.nih.gov]
- 9. discovery.ucl.ac.uk [discovery.ucl.ac.uk]
- 10. researchgate.net [researchgate.net]
- 11. pubs.acs.org [pubs.acs.org]
- 12. benchchem.com [benchchem.com]
- To cite this document: BenchChem. [Application Notes and Protocols: TCO-PEG24-Acid for Proteomic Sample Preparation]. BenchChem, [2026]. [Online PDF]. Available at: [<https://www.benchchem.com/product/b15544463/docs#application-notes-and-protocols-tco-peg24-acid-for-proteomic-sample-preparation>]

Disclaimer & Data Validity:

The information provided in this document is for Research Use Only (RUO) and is strictly not intended for diagnostic or therapeutic procedures. While BenchChem strives to provide

accurate protocols, we make no warranties, express or implied, regarding the fitness of this product for every specific experimental setup.

Technical Support: The protocols provided are for reference purposes. Unsure if this reagent suits your experiment?

Need Industrial/Bulk Grade? [Request Custom Synthesis Quote](#)

BenchChem

Our mission is to be the trusted global source of essential and advanced chemicals, empowering scientists and researchers to drive progress in science and industry.

Contact

Address: 3281 E Guasti Rd

Ontario, CA 91761, United States

Phone: (601) 213-4426

Email: info@benchchem.com

[Contact our Ph.D. Support Team for a compatibility check](#)