

A Guide to Cross-Validation of Analytical Methods Using Different Deuterated Internal Standards

Author: BenchChem Technical Support Team. **Date:** April 2026

Compound of Interest

Compound Name: Mestranol-d2

Cat. No.: B15544609

[Get Quote](#)

For researchers, scientists, and drug development professionals, the integrity and consistency of bioanalytical data are non-negotiable. When analytical methods evolve or are transferred between laboratories, a rigorous cross-validation process is essential to ensure data comparability. This is particularly critical when different deuterated internal standards are employed for the same analyte. This guide provides an objective comparison of the performance considerations when cross-validating such methods, supported by detailed experimental protocols and illustrative data.

Stable isotope-labeled internal standards (SIL-ISs), especially deuterated standards, are the gold standard in quantitative bioanalysis by liquid chromatography-mass spectrometry (LC-MS).[1] Their near-identical physicochemical properties to the analyte allow for effective compensation for variability during sample preparation and analysis.[2] However, the number and position of deuterium atoms can influence analytical performance, creating challenges during cross-validation.

Comparing Performance of Different Deuterated Standards

The choice of a deuterated internal standard can impact several key analytical parameters. While a standard with a higher degree of deuteration (e.g., d5 or greater) is often preferred to minimize isotopic interference from the analyte, it's not without potential drawbacks.[3] The following table summarizes the potential performance differences between two hypothetical deuterated standards for the same analyte, "Analyte X": a d3-labeled standard (IS-A) and a d5-labeled standard (IS-B).

Parameter	Method A (Analyte X with IS-A, d3)	Method B (Analyte X with IS-B, d5)	Key Considerations & Potential Findings
Chromatographic Separation	Analyte and IS may co-elute.	Potential for partial separation of analyte and IS due to a more pronounced deuterium isotope effect.[4]	A slight retention time shift between the analyte and the d5-IS could lead to differential matrix effects, potentially impacting accuracy and precision.[5]
Accuracy	High	High, but may be compromised if chromatographic shift leads to differential matrix effects.	The accuracy of both methods should be within acceptable limits (typically $\pm 15\%$ of the nominal value). Any significant bias between the two methods must be investigated.
Precision	High	High, but may be more variable if matrix effects are not adequately compensated for due to chromatographic separation.	The precision, expressed as the coefficient of variation (%CV), should be $\leq 15\%$. Inconsistent precision between the two methods can indicate a problem with one of the internal standards.
Isotopic Contribution	Higher potential for interference from the M+3 isotope of the analyte, especially at	Lower potential for isotopic interference from the analyte.	The isotopic purity of the deuterated standard is crucial. The presence of unlabeled analyte in

	high analyte concentrations.		the internal standard solution can lead to an overestimation of the analyte concentration.
Isotopic Exchange(Back-Exchange)	Dependent on the position of the deuterium labels.	Dependent on the position of the deuterium labels.	Deuterium atoms on labile positions (e.g., -OH, -NH) are prone to exchange with protons from the solvent, leading to a loss of the mass difference and compromising the integrity of the analysis.[3][6]

Experimental Protocols

A successful cross-validation of analytical methods with different deuterated standards requires a well-defined protocol. Below are detailed methodologies for key experiments.

Cross-Validation Sample Analysis

Objective: To compare the performance of two analytical methods using different deuterated internal standards.

Protocol:

- **Sample Selection:** Select a minimum of 30 incurred samples from a relevant study, covering the entire calibration range. If incurred samples are not available, use quality control (QC) samples at low, medium, and high concentrations.[7]
- **Sample Analysis:** Analyze the selected samples using both Method A (with IS-A) and Method B (with IS-B).
- **Data Evaluation:** Statistically compare the concentration data obtained from both methods. The difference between the values obtained by the two methods should be within a predefined acceptance criterion (e.g., $\pm 20\%$ for at least 67% of the samples).[8]

Assessment of Chromatographic Isotope Effect

Objective: To evaluate any retention time differences between the analyte and the different deuterated internal standards.

Protocol:

- **Sample Preparation:** Prepare a solution containing the analyte and both deuterated internal standards (IS-A and IS-B) in the final mobile phase composition.
- **LC-MS/MS Analysis:** Inject the solution and carefully monitor the retention times of the analyte and both internal standards.
- **Data Evaluation:** Calculate the separation factor (α) between the analyte and each internal standard. An α value different from 1.0 indicates a chromatographic isotope effect.[9]

Evaluation of Isotopic Exchange

Objective: To assess the stability of the deuterated internal standards and their susceptibility to back-exchange.

Protocol:

- **Sample Preparation:** Prepare solutions of each deuterated internal standard in various matrices relevant to the study (e.g., plasma, mobile phase at different pH values).
- **Incubation:** Incubate these solutions under different conditions (e.g., room temperature for 24 hours, 37°C for 4 hours).
- **LC-MS/MS Analysis:** Analyze the incubated solutions and a freshly prepared control solution.
- **Data Evaluation:** Compare the peak areas of the deuterated standards between the incubated and control samples. A significant decrease in the peak area of the deuterated standard in the incubated samples may indicate isotopic exchange. Also, monitor for any increase in the signal of the unlabeled analyte.[10]

Mandatory Visualizations

To further clarify the described processes, the following diagrams have been generated using the DOT language.

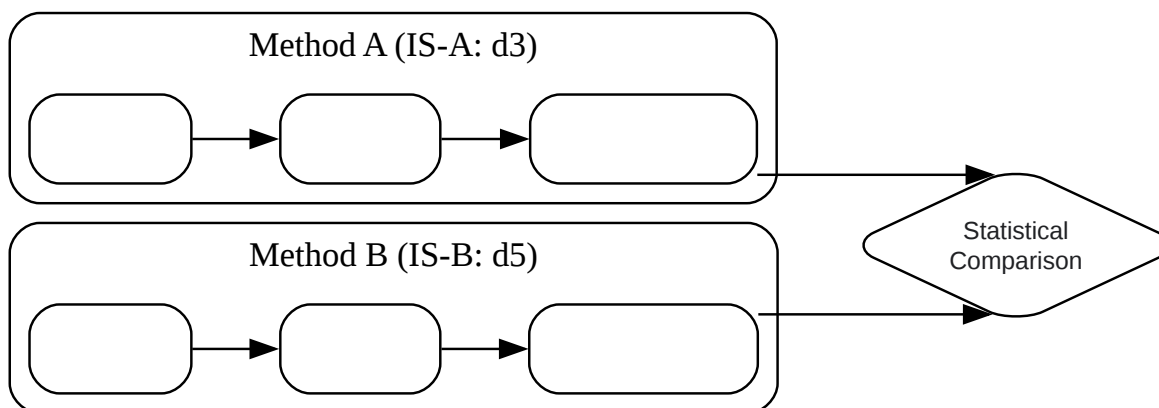

[Click to download full resolution via product page](#)

Caption: Cross-validation workflow for two methods with different deuterated standards.

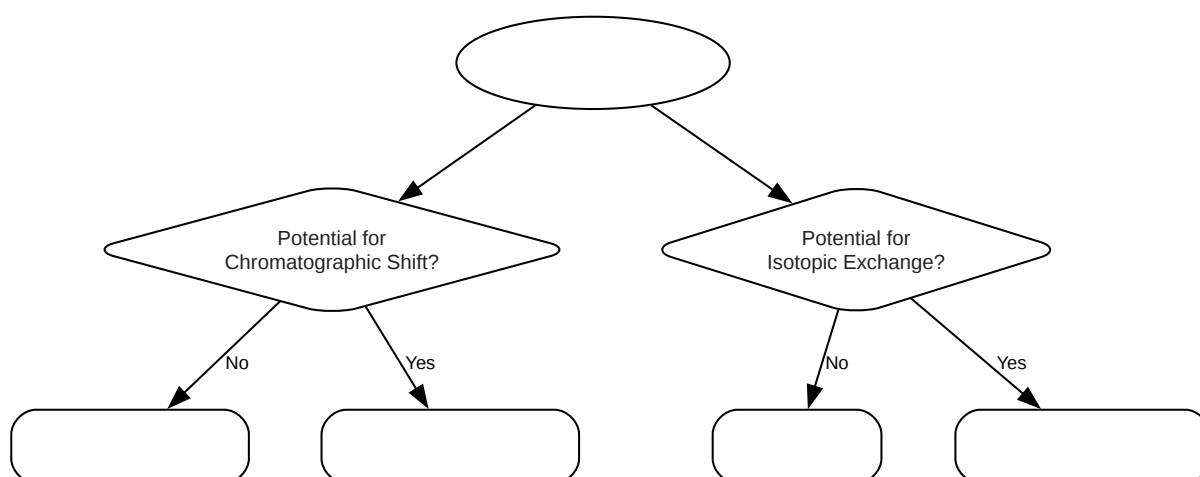

[Click to download full resolution via product page](#)

Caption: Decision pathway for evaluating the suitability of a deuterated internal standard.

In conclusion, the cross-validation of analytical methods using different deuterated internal standards is a critical exercise to ensure data integrity. While stable isotope-labeled standards are the preferred choice, careful consideration of potential issues such as chromatographic isotope effects and isotopic exchange is necessary. By following robust experimental protocols and thoroughly evaluating the data, researchers can be confident in the comparability of results from different analytical methods.

Need Custom Synthesis?

BenchChem offers custom synthesis for rare earth carbides and specific isotopic labeling.

Email: info@benchchem.com or [Request Quote Online](#).

References

- [1. benchchem.com \[benchchem.com\]](#)
- [2. benchchem.com \[benchchem.com\]](#)
- [3. benchchem.com \[benchchem.com\]](#)
- [4. chromatographyonline.com \[chromatographyonline.com\]](#)
- [5. benchchem.com \[benchchem.com\]](#)
- [6. benchchem.com \[benchchem.com\]](#)
- [7. e-b-f.eu \[e-b-f.eu\]](#)
- [8. Statistical Considerations for Assessment of Bioanalytical Incurred Sample Reproducibility - PMC \[pmc.ncbi.nlm.nih.gov\]](#)
- [9. benchchem.com \[benchchem.com\]](#)
- [10. benchchem.com \[benchchem.com\]](#)
- To cite this document: BenchChem. [A Guide to Cross-Validation of Analytical Methods Using Different Deuterated Internal Standards]. BenchChem, [2026]. [Online PDF]. Available at: [<https://www.benchchem.com/product/b15544609/docs#a-guide-to-cross-validation-of-analytical-methods-using-different-deuterated-internal-standards>]

Disclaimer & Data Validity:

The information provided in this document is for Research Use Only (RUO) and is strictly not intended for diagnostic or therapeutic procedures. While BenchChem strives to provide accurate protocols, we make no warranties, express or implied, regarding the fitness of this product for every specific experimental setup.

Technical Support: The protocols provided are for reference purposes. Unsure if this reagent suits your experiment?

Need Industrial/Bulk Grade? [Request Custom Synthesis Quote](#)

BenchChem

Our mission is to be the trusted global source of essential and advanced chemicals, empowering scientists and researchers to drive progress in science and industry.

Contact

Address: 3281 E Guasti Rd
Ontario, CA 91761, United States
Phone: (601) 213-4426
Email: info@benchchem.com

[Contact our Ph.D. Support Team for a compatibility check](#)