

# Technical Support Center: Overcoming Resistance to CK2 Inhibitors

**Author:** BenchChem Technical Support Team. **Date:** April 2026

## Compound of Interest

Compound Name: CK2-IN-9  
Cat. No.: B15543544

[Get Quote](#)

This technical support center provides troubleshooting guides and frequently asked questions (FAQs) for researchers, scientists, and drug development professionals encountering resistance to the protein kinase CK2 inhibitor, **CK2-IN-9**, in cancer cells.

## Frequently Asked Questions (FAQs)

Q1: We are observing reduced sensitivity to **CK2-IN-9** in our cancer cell line over time. What are the potential mechanisms of resistance?

A1: Resistance to CK2 inhibitors can arise from several factors. Cancer cells are known to be highly dependent on CK2 for survival and proliferation, a phenomenon sometimes referred to as "non-oncogene addiction".<sup>[1]</sup> The primary mechanisms of acquired resistance often involve the activation of pro-survival signaling pathways that compensate for the inhibition of CK2. Key pathways implicated include:

- **PI3K/Akt/mTOR Pathway:** This is a central signaling cascade that promotes cell growth, proliferation, and survival. CK2 is known to positively regulate this pathway, and its inhibition can sometimes lead to a compensatory upregulation of Akt signaling.

- **NF-κB Signaling:** The NF-κB pathway is crucial for inflammation, immunity, and cell survival. CK2 can activate NF-κB, and resistance to CK2 inhibitors has been associated with the potentiation of NF-κB signaling.[2]
- **Drug Efflux Pumps:** Increased expression or activity of ATP-binding cassette (ABC) transporters, such as P-glycoprotein (P-gp), can lead to the active removal of the inhibitor from the cell, reducing its intracellular concentration and efficacy.[3]
- **Upregulation of CK2 Expression:** In some cases, resistant cells may exhibit overexpression of the CK2 catalytic subunits (α and/or α').[3]

Q2: How can we experimentally confirm the mechanism of resistance in our cell line?

A2: To investigate the specific mechanism of resistance in your cell line, we recommend the following experimental approaches:

- **Western Blotting:** Analyze the phosphorylation status of key proteins in the PI3K/Akt/mTOR and NF-κB pathways. Look for increased phosphorylation of Akt (at Ser473 and Thr308) and IκBα (at Ser32/36) in resistant cells compared to sensitive cells upon treatment with **CK2-IN-9**. You can also assess the total protein levels of CK2 subunits.
- **Gene Expression Analysis:** Use qRT-PCR to measure the mRNA levels of genes encoding drug efflux pumps (e.g., ABCB1 for P-gp).
- **Flow Cytometry:** Assess the activity of drug efflux pumps using fluorescent substrates like Rhodamine 123. A lower intracellular fluorescence in resistant cells would indicate increased pump activity.

Q3: What strategies can we employ to overcome resistance to **CK2-IN-9**?

A3: Several strategies can be explored to overcome resistance:

- **Combination Therapy:** Combining **CK2-IN-9** with inhibitors of the identified resistance pathways can have a synergistic effect. For instance, co-treatment with a PI3K inhibitor (e.g., Wortmannin) or an NF-κB inhibitor (e.g., BAY 11-7082) may re-sensitize resistant cells. Studies have shown that the CK2 inhibitor CX-4945 has synergistic effects when combined with other anti-cancer drugs.[4]

- **Development of Next-Generation Inhibitors:** While beyond the scope of a typical research lab, the development of new CK2 inhibitors with different binding modes or improved potency against resistant clones is an active area of research.
- **Modulation of Drug Efflux:** The use of P-gp inhibitors, such as Verapamil or Tariquidar, in combination with **CK2-IN-9** can increase its intracellular accumulation in cells overexpressing this transporter.

## Troubleshooting Guides

Problem: Decreased potency (higher IC50) of **CK2-IN-9** in our cell line compared to published data.

Possible Cause	Troubleshooting Step
Cell line is inherently resistant.	Analyze the baseline activity of pro-survival pathways like PI3K/Akt and NF-κB in your untreated cells. High basal activity may indicate a lower dependence on CK2.
Suboptimal inhibitor exposure time.	Perform a time-course experiment (e.g., 24, 48, 72 hours) to determine the optimal treatment duration for inducing cell death.
Inhibitor degradation.	Prepare fresh stock solutions of CK2-IN-9 and store them under the recommended conditions. Avoid repeated freeze-thaw cycles.
Presence of drug efflux pumps.	Assess the expression and activity of P-glycoprotein and other ABC transporters.

Problem: **CK2-IN-9** treatment does not induce the expected level of apoptosis.

Possible Cause	Troubleshooting Step
Activation of compensatory anti-apoptotic pathways.	Investigate the expression levels of anti-apoptotic proteins (e.g., Bcl-2, Mcl-1) by Western blotting.
Insufficient inhibition of CK2 activity.	Confirm the inhibition of CK2 activity in your cells using an in vitro kinase assay or by assessing the phosphorylation of a known CK2 substrate.
Cell cycle arrest instead of apoptosis.	Analyze the cell cycle distribution of treated cells by flow cytometry to determine if the inhibitor is causing a G1 or G2/M arrest rather than apoptosis.

## Data Presentation

Table 1: Efficacy of the CK2 Inhibitor CX-4945 (Silmitasertib) in Sensitive vs. Resistant Cancer Cell Lines

Cell Line	Cancer Type	Resistance Status	IC50 ( $\mu\text{M}$ )	Reference
MCF-7	Breast Cancer	Sensitive	1.8	
MCF-7 Palbo-R	Breast Cancer	Palbociclib-Resistant	16.7	
T47D	Breast Cancer	Sensitive	Not specified	
T47D Palbo-R	Breast Cancer	Palbociclib-Resistant	Not specified	
Jurkat	Leukemia	Not specified	0.1 (endogenous CK2 activity)	
CLL	Leukemia	Not specified	< 1	
BT-474	Breast Cancer	Not specified	1.71-20.01	
MDA-MB-231	Breast Cancer	Not specified	1.71-20.01	

Note: Data for the specific inhibitor **CK2-IN-9** is limited in the public domain. CX-4945 is a well-characterized, potent, and selective CK2 inhibitor often used in research and clinical trials.

## Experimental Protocols

### Western Blotting for Phosphorylated CK2 Substrates

This protocol allows for the detection of changes in the phosphorylation state of CK2 substrates.

Materials:

- RIPA buffer with protease and phosphatase inhibitors
- BCA or Bradford assay kit
- Laemmli sample buffer
- SDS-PAGE gels

- PVDF membrane
- Blocking buffer (5% BSA in TBST)
- Primary antibody against a phosphorylated CK2 substrate (e.g., phospho-Akt Ser129, phospho-p65 Ser529)
- HRP-conjugated secondary antibody
- Chemiluminescent substrate
- Imaging system

#### Procedure:

- Cell Lysis: Treat cells with **CK2-IN-9** for the desired time. Wash cells with ice-cold PBS and lyse them in RIPA buffer.
- Protein Quantification: Determine the protein concentration of the lysate using a BCA or Bradford assay.
- SDS-PAGE: Denature equal amounts of protein (20-40  $\mu$ g) by boiling in Laemmli sample buffer. Separate the proteins on an SDS-PAGE gel.
- Protein Transfer: Transfer the separated proteins to a PVDF membrane.
- Blocking: Block the membrane with 5% BSA in TBST for 1 hour at room temperature.
- Primary Antibody Incubation: Incubate the membrane with the primary antibody diluted in blocking buffer overnight at 4°C.
- Washing: Wash the membrane three times for 10 minutes each with TBST.
- Secondary Antibody Incubation: Incubate the membrane with the HRP-conjugated secondary antibody for 1 hour at room temperature.
- Washing: Repeat the washing step.

- Detection: Incubate the membrane with a chemiluminescent substrate and capture the signal using an imaging system.

## Annexin V/PI Apoptosis Assay by Flow Cytometry

This protocol quantifies the percentage of apoptotic and necrotic cells following treatment with **CK2-IN-9**.

Materials:

- Annexin V-FITC and Propidium Iodide (PI) staining kit
- 1X Binding Buffer
- Flow cytometry tubes
- Flow cytometer

Procedure:

- Cell Treatment: Treat cells with **CK2-IN-9** for the desired time to induce apoptosis.
- Cell Harvesting: Harvest both adherent and floating cells. Wash the cells twice with cold PBS.
- Staining: Resuspend the cells in 1X Binding Buffer at a concentration of  $1 \times 10^6$  cells/mL.
- Transfer 100  $\mu$ L of the cell suspension to a flow cytometry tube.
- Add 5  $\mu$ L of Annexin V-FITC and 5  $\mu$ L of PI solution.
- Gently vortex the cells and incubate for 15 minutes at room temperature in the dark.
- Flow Cytometry Analysis: Add 400  $\mu$ L of 1X Binding Buffer to each tube. Analyze the samples on a flow cytometer within one hour.
  - Live cells: Annexin V-negative, PI-negative
  - Early apoptotic cells: Annexin V-positive, PI-negative

- Late apoptotic/necrotic cells: Annexin V-positive, PI-positive

## In Vitro CK2 Kinase Assay

This protocol measures the direct inhibitory effect of **CK2-IN-9** on CK2's enzymatic activity.

Materials:

- Recombinant human CK2 enzyme
- CK2-specific peptide substrate (e.g., RRRADDSDDDDDD)
- **CK2-IN-9**
- Kinase assay buffer
- [ $\gamma$ - $^{32}$ P]ATP or a non-radioactive kinase assay kit (e.g., ADP-Glo™)
- P81 phosphocellulose paper (for radioactive assay)
- Scintillation counter or luminometer

Procedure (using a non-radioactive ADP-Glo™ Assay):

- Set up the kinase reaction in a 96-well plate by adding the kinase assay buffer, CK2 enzyme, and the peptide substrate.
- Add **CK2-IN-9** at various concentrations.
- Initiate the reaction by adding ATP.
- Incubate at 30°C for 30-60 minutes.
- Add the ADP-Glo™ Reagent to terminate the kinase reaction and deplete the remaining ATP.
- Add the Kinase Detection Reagent to convert ADP to ATP and generate a luminescent signal.

- Measure the luminescence using a luminometer. The signal is inversely correlated with kinase activity.

## Visualizations

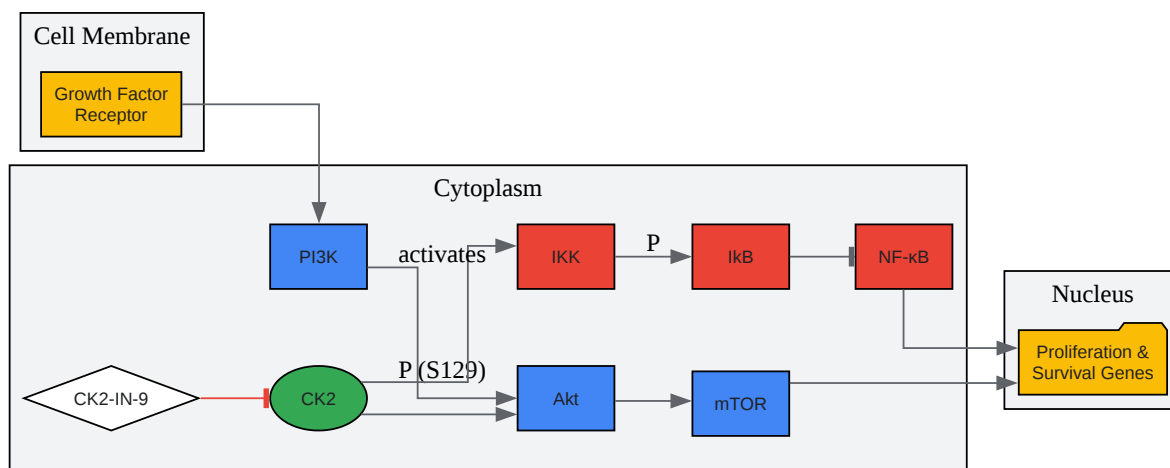

[Click to download full resolution via product page](#)

Caption: CK2 signaling pathways promoting cancer cell survival.

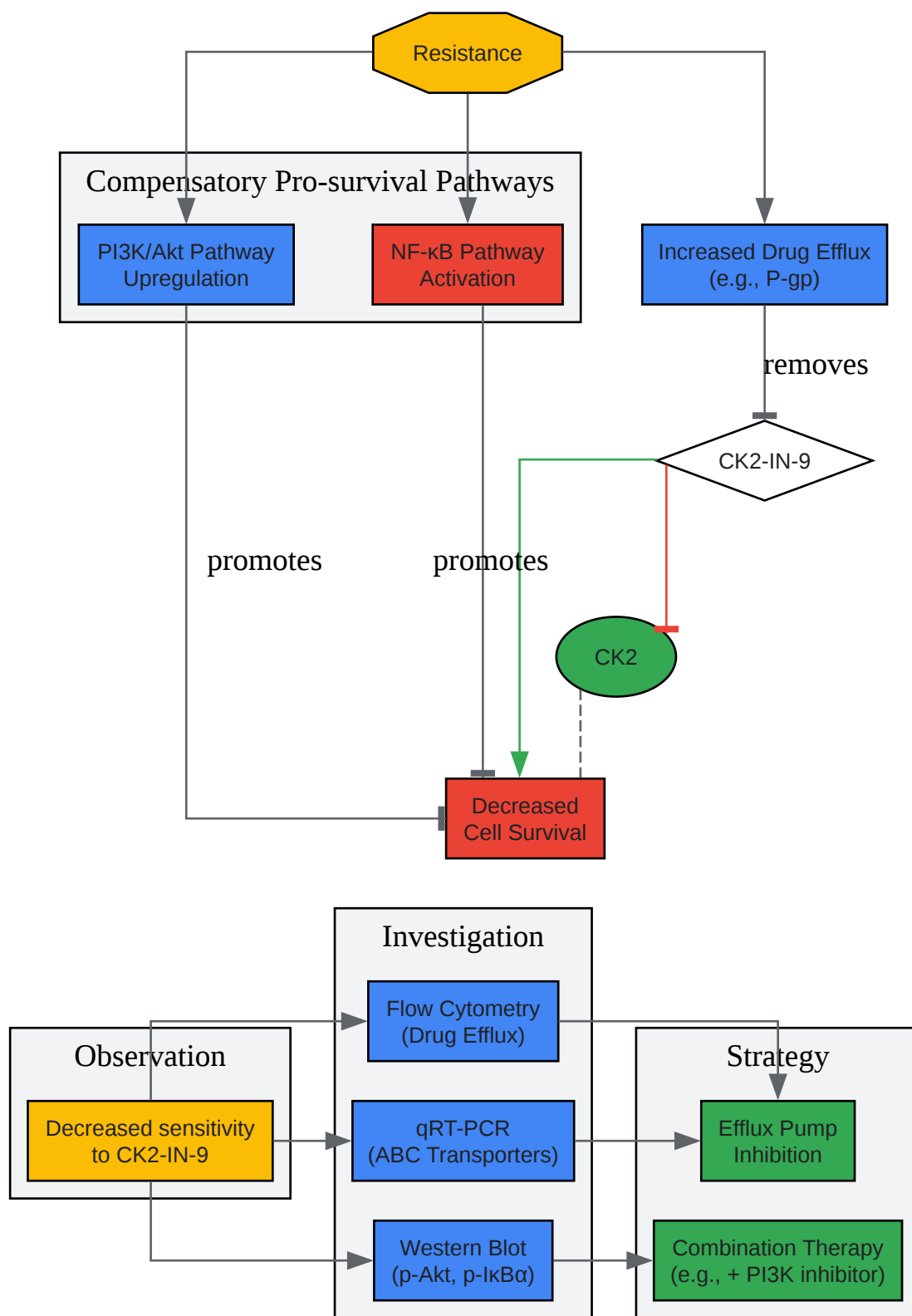

[Click to download full resolution via product page](#)

### Need Custom Synthesis?

BenchChem offers custom synthesis for rare earth carbides and specific isotopic labeling.

Email: [info@benchchem.com](mailto:info@benchchem.com) or [Request Quote Online](#).

## References

- [1. researchgate.net \[researchgate.net\]](https://www.researchgate.net)
- [2. Role of protein kinase CK2 in antitumor drug resistance - PMC \[pmc.ncbi.nlm.nih.gov\]](https://pubmed.ncbi.nlm.nih.gov/123456789/)
- [3. Comparative analysis of CK2 expression and function in tumor cell lines displaying sensitivity vs. resistance to chemical induced apoptosis - PubMed \[pubmed.ncbi.nlm.nih.gov\]](https://pubmed.ncbi.nlm.nih.gov/123456789/)
- [4. Role of protein kinase CK2 in antitumor drug resistance - PubMed \[pubmed.ncbi.nlm.nih.gov\]](https://pubmed.ncbi.nlm.nih.gov/123456789/)
- To cite this document: BenchChem. [Technical Support Center: Overcoming Resistance to CK2 Inhibitors]. BenchChem, [2026]. [Online PDF]. Available at: [\[https://www.benchchem.com/product/b15543544/docs#technical-support-center-overcoming-resistance-to-ck2-inhibitors\]](https://www.benchchem.com/product/b15543544/docs#technical-support-center-overcoming-resistance-to-ck2-inhibitors)

---

### Disclaimer & Data Validity:

The information provided in this document is for Research Use Only (RUO) and is strictly not intended for diagnostic or therapeutic procedures. While BenchChem strives to provide accurate protocols, we make no warranties, express or implied, regarding the fitness of this product for every specific experimental setup.

**Technical Support:** The protocols provided are for reference purposes. Unsure if this reagent suits your experiment?

**Need Industrial/Bulk Grade?** [Request Custom Synthesis Quote](#)

# BenchChem

Our mission is to be the trusted global source of essential and advanced chemicals, empowering scientists and researchers to drive progress in science and industry.

## Contact

Address: 3281 E Guasti Rd

Ontario, CA 91761, United States

Phone: (601) 213-4426

Email: [info@benchchem.com](mailto:info@benchchem.com)

[Contact our Ph.D. Support Team for a compatibility check](#)