

# Technical Support Center: Enhancing the Selectivity of KDU731 for Parasite PI4K

**Author:** BenchChem Technical Support Team. **Date:** April 2026

## Compound of Interest

Compound Name:	KDU731
CAS No.:	1610610-35-9
Cat. No.:	B15543579

[Get Quote](#)

This technical support center provides researchers, scientists, and drug development professionals with comprehensive guidance on utilizing **KDU731**, a potent and selective inhibitor of *Cryptosporidium* phosphatidylinositol-4-OH kinase (PI4K). Here you will find answers to frequently asked questions, troubleshooting guides for common experimental issues, detailed experimental protocols, and a summary of key quantitative data.

## Frequently Asked Questions (FAQs)

Q1: What is **KDU731** and what is its primary target?

A1: **KDU731** is a pyrazolopyridine-based compound identified as a potent and selective inhibitor of the *Cryptosporidium* lipid kinase, phosphatidylinositol-4-OH kinase (PI4K).<sup>[1][2][3]</sup> It is a promising drug candidate for the treatment of cryptosporidiosis, a diarrheal disease caused by the protozoan parasite *Cryptosporidium*.<sup>[1][2][4]</sup>

Q2: What is the mechanism of action of **KDU731**?

A2: **KDU731** acts as an ATP-competitive inhibitor of *Cryptosporidium* PI4K (CpPI(4)K).<sup>[1]</sup> This means it binds to the ATP-binding site of the enzyme, preventing the transfer of a phosphate

group from ATP to its substrate, phosphatidylinositol.[1][3] This inhibition of PI4K activity disrupts essential processes in the parasite, leading to the inhibition of its growth and replication.[1][5]

Q3: How selective is **KDU731** for parasite PI4K over human PI4K?

A3: **KDU731** exhibits a significant selectivity for parasite PI4K. It has been shown to have a greater than 50-fold selectivity window against the human PI(4)K III $\beta$  homologue.[1] This selectivity is a crucial factor in its favorable safety profile, as it minimizes off-target effects on the host.[1][6]

Q4: Against which *Cryptosporidium* species is **KDU731** effective?

A4: **KDU731** has demonstrated potent activity against both *Cryptosporidium parvum* and *Cryptosporidium hominis*, the two species responsible for the majority of human infections.[1][5]

Q5: What are the demonstrated in vivo effects of **KDU731**?

A5: In preclinical studies, oral administration of **KDU731** has been shown to be highly effective in reducing intestinal parasite load in immunocompromised mouse models of cryptosporidiosis.[1][4] Furthermore, in a neonatal calf model, which closely mimics human clinical disease, **KDU731** treatment led to a rapid resolution of diarrhea and dehydration.[1][4]

## Troubleshooting Guide

Issue 1: Inconsistent IC<sub>50</sub>/EC<sub>50</sub> values in in vitro growth inhibition assays.

- Possible Cause 1: Variability in Host Cell Health. The viability and confluency of the host cell monolayer (e.g., HCT-8 cells) can significantly impact parasite infectivity and growth.
  - Solution: Ensure consistent cell seeding density and monitor cell health and confluency prior to infection. Only use cells within a specific passage number range.
- Possible Cause 2: Oocyst Viability and Excystation Efficiency. The age and storage conditions of *C. parvum* oocysts can affect their viability and ability to excyst, leading to variable infection rates.

- Solution: Use freshly sourced and properly stored oocysts. Perform a viability assay (e.g., using propidium iodide staining) and an excystation assay prior to each experiment to ensure consistency.
- Possible Cause 3: Inconsistent Compound Concentration. Errors in serial dilutions or degradation of the compound can lead to inaccurate final concentrations.
  - Solution: Prepare fresh serial dilutions of **KDU731** for each experiment from a well-characterized stock solution. Store the stock solution at the recommended temperature and protect it from light.

Issue 2: High background signal in the PI4K enzymatic assay.

- Possible Cause 1: Contaminating Kinase Activity. The purified recombinant CpPI(4)K enzyme preparation may contain other contaminating kinases.
  - Solution: Verify the purity of the recombinant CpPI(4)K using SDS-PAGE and consider further purification steps if necessary.
- Possible Cause 2: Non-enzymatic ATP hydrolysis. High concentrations of ATP or certain buffer components can lead to non-enzymatic breakdown of ATP, resulting in a false-positive signal in ADP-detecting assays.
  - Solution: Run control reactions without the enzyme to determine the level of non-enzymatic ATP hydrolysis. Optimize the ATP concentration to be within the linear range of the assay.

Issue 3: Apparent lack of **KDU731** efficacy in an in vivo model.

- Possible Cause 1: Poor Compound Formulation and Bioavailability. The formulation of **KDU731** for oral administration can significantly impact its solubility and absorption.
  - Solution: Ensure a proper suspension or solid dispersion formulation is used to maximize systemic exposure.[1] Conduct pharmacokinetic studies to determine the plasma and tissue concentrations of **KDU731**.

- Possible Cause 2: Timing and Dose of Treatment. The timing of treatment initiation and the dosage used may not be optimal for the specific animal model.
  - Solution: Initiate treatment at the peak of infection and test a range of doses to determine the most effective regimen.[1]
- Possible Cause 3: High Parasite Inoculum. An excessively high oocyst inoculum may overwhelm the therapeutic effect of the compound.
  - Solution: Use a standardized and validated oocyst inoculum for infection that has been shown to be responsive to treatment in previous studies.

## Quantitative Data Summary

The following tables summarize the key quantitative data for **KDU731**'s activity and selectivity.

Parameter	Value	Assay/Model	Reference
IC50 for CpPI(4)K	25 nM	Enzymatic Assay	[1][7]
EC50 against <i>C. parvum</i>	0.1 $\mu$ M	In vitro growth in HCT-8 cells	[1]
CC50 in HepG2 cells	15.6 $\mu$ M	Cytotoxicity Assay	[1]
Selectivity Index (CC50/EC50)	> 100	[1]	
Selectivity vs. human PI(4)KIII $\beta$	> 50-fold	Enzymatic Assay	[1]

## Experimental Protocols

### 1. In Vitro Growth Inhibition Assay of *C. parvum*

This protocol is based on methods used to assess the efficacy of anti-cryptosporidial compounds in a human ileocecal adenocarcinoma (HCT-8) cell line.

- Materials:

- HCT-8 cells
- Complete growth medium (e.g., RPMI 1640 with 10% FBS, 2 mM L-glutamine, 100 U/mL penicillin, 100 µg/mL streptomycin)
- *C. parvum* oocysts
- **KDU731** stock solution (in DMSO)
- 96-well microplates
- Fluorescently labeled antibody against *Cryptosporidium*
- DAPI nuclear stain
- High-content imaging system
- Procedure:
  - Seed HCT-8 cells in 96-well plates and grow to 80-90% confluency.
  - Prepare serial dilutions of **KDU731** in the growth medium.
  - Excyst *C. parvum* oocysts by incubation in an acidic solution followed by a basic solution containing taurocholic acid.
  - Remove the growth medium from the HCT-8 cells and add the **KDU731** dilutions.
  - Infect the cells with the excysted sporozoites.
  - Incubate the plates for 48 hours at 37°C in a 5% CO<sub>2</sub> atmosphere.
  - Fix the cells with 4% paraformaldehyde.
  - Permeabilize the cells with 0.1% Triton X-100.
  - Stain with a fluorescently labeled anti-*Cryptosporidium* antibody and DAPI.

- Acquire images using a high-content imaging system and quantify the number of parasites.
- Calculate the EC50 value by fitting the dose-response data to a four-parameter logistic curve.

## 2. CpPI(4)K Enzymatic Assay

This protocol describes a method to measure the enzymatic activity of recombinant *C. parvum* PI(4)K and the inhibitory effect of **KDU731**.

- Materials:
  - Purified recombinant CpPI(4)K enzyme
  - PI(4)K substrate (e.g., phosphatidylinositol)
  - ATP
  - **KDU731** stock solution (in DMSO)
  - Assay buffer (e.g., 20 mM Tris-HCl pH 7.5, 5 mM MgCl<sub>2</sub>, 0.5 mM EGTA)
  - ADP-Glo™ Kinase Assay kit (Promega) or similar ADP detection system
  - 384-well plates
  - Luminometer
- Procedure:
  - Prepare serial dilutions of **KDU731** in the assay buffer.
  - In a 384-well plate, add the CpPI(4)K enzyme, PI(4)K substrate, and **KDU731** dilutions.
  - Initiate the kinase reaction by adding ATP.
  - Incubate the reaction at room temperature for a specified time (e.g., 60 minutes).

- Stop the reaction and detect the amount of ADP produced using the ADP-Glo™ Kinase Assay kit according to the manufacturer's instructions.
- Measure the luminescence using a luminometer.
- Calculate the IC50 value by fitting the dose-response data to a four-parameter logistic curve.

## Visualizations

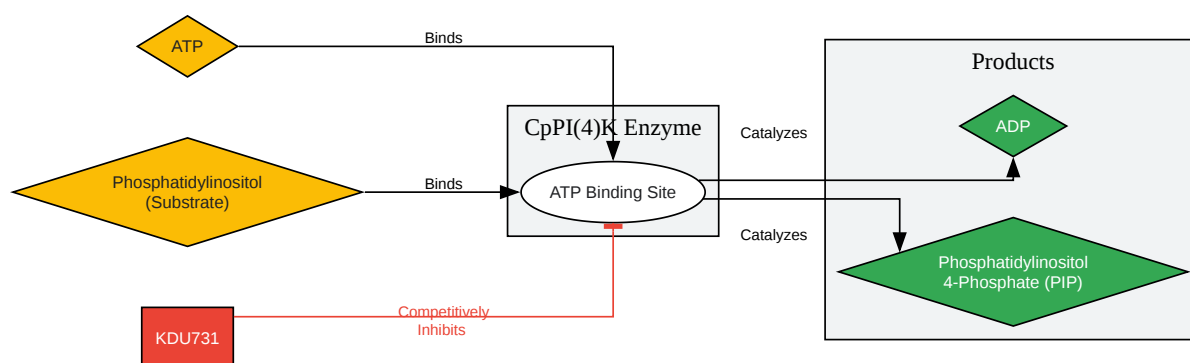

[Click to download full resolution via product page](#)

Caption: Mechanism of action of **KDU731** as an ATP-competitive inhibitor of CpPI(4)K.

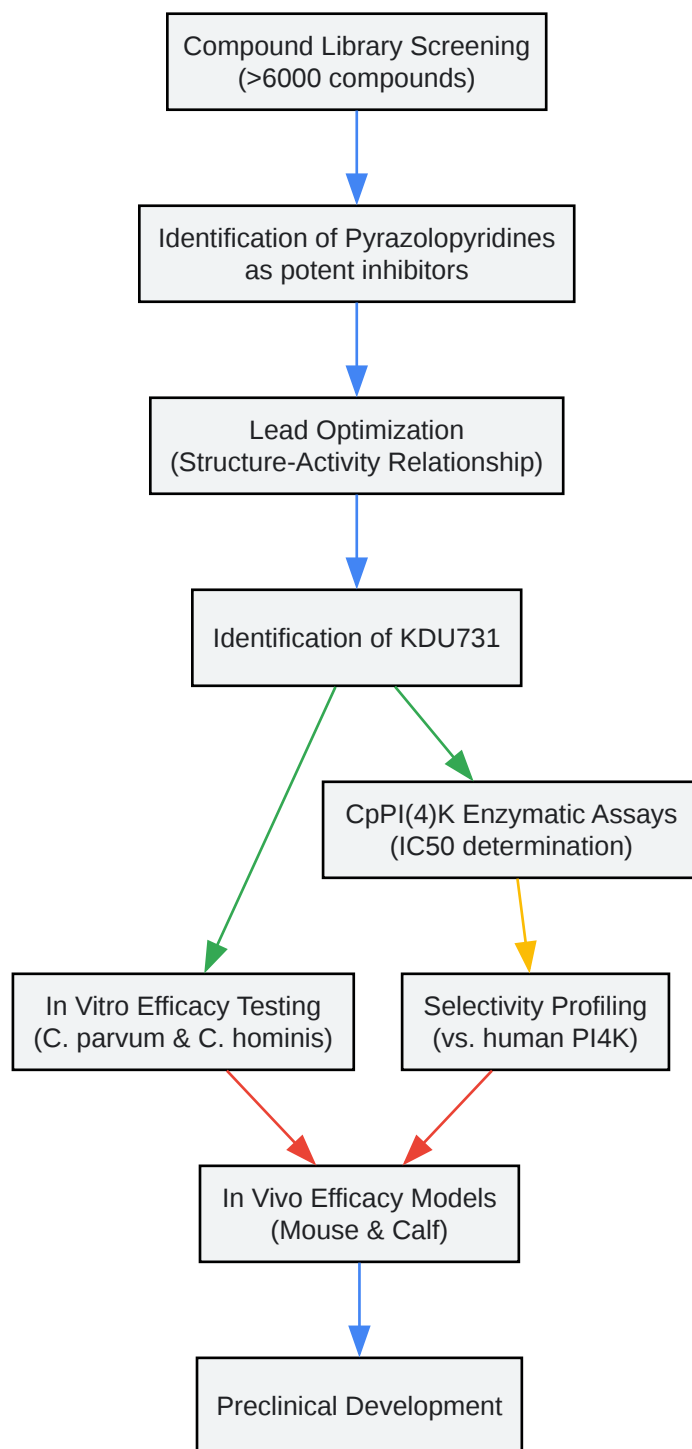

[Click to download full resolution via product page](#)

Caption: Drug discovery workflow leading to the identification of **KDU731**.

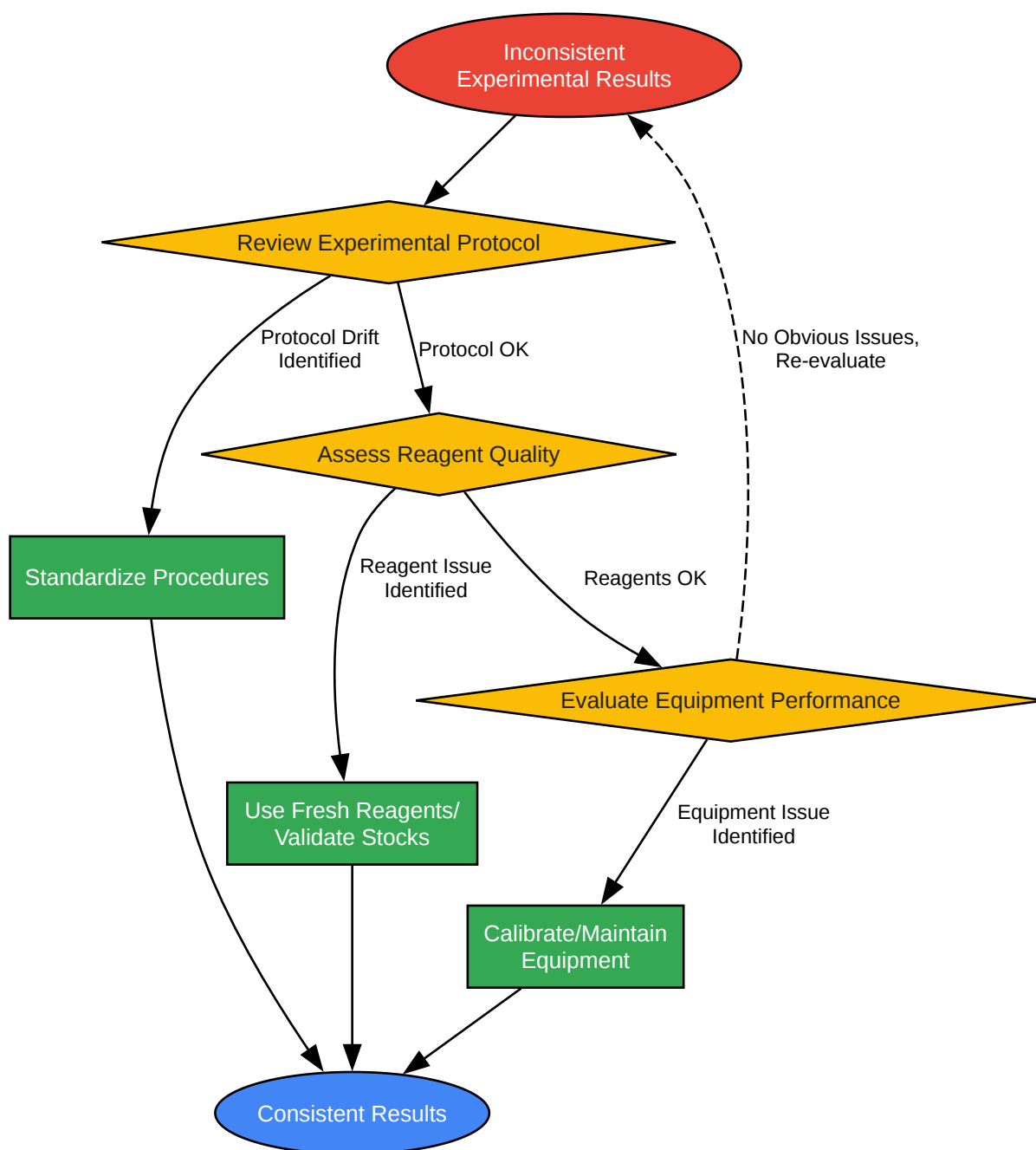

[Click to download full resolution via product page](#)

**Need Custom Synthesis?**

BenchChem offers custom synthesis for rare earth carbides and specific isotopic labeling.

Email: [info@benchchem.com](mailto:info@benchchem.com) or [Request Quote Online](#).

## References

- [1. A Cryptosporidium PI\(4\)K inhibitor is a drug candidate for cryptosporidiosis - PMC \[pmc.ncbi.nlm.nih.gov\]](#)
- [2. A Cryptosporidium PI\(4\)K inhibitor is a drug candidate for cryptosporidiosis – ScienceOpen \[scienceopen.com\]](#)
- [3. bellbrooklabs.com \[bellbrooklabs.com\]](#)
- [4. A Cryptosporidium PI\(4\)K inhibitor is a drug candidate for cryptosporidiosis - PubMed \[pubmed.ncbi.nlm.nih.gov\]](#)
- [5. Treating cryptosporidiosis: A review on drug discovery strategies - PMC \[pmc.ncbi.nlm.nih.gov\]](#)
- [6. tandfonline.com \[tandfonline.com\]](#)
- [7. medchemexpress.com \[medchemexpress.com\]](#)
- To cite this document: BenchChem. [Technical Support Center: Enhancing the Selectivity of KDU731 for Parasite PI4K]. BenchChem, [2026]. [Online PDF]. Available at: [\[https://www.benchchem.com/product/b15543579/docs#technical-support-center-enhancing-the-selectivity-of-kdu731-for-parasite-pi4k\]](https://www.benchchem.com/product/b15543579/docs#technical-support-center-enhancing-the-selectivity-of-kdu731-for-parasite-pi4k)

---

### Disclaimer & Data Validity:

The information provided in this document is for Research Use Only (RUO) and is strictly not intended for diagnostic or therapeutic procedures. While BenchChem strives to provide accurate protocols, we make no warranties, express or implied, regarding the fitness of this product for every specific experimental setup.

**Technical Support:** The protocols provided are for reference purposes. Unsure if this reagent suits your experiment?

**Need Industrial/Bulk Grade?** [Request Custom Synthesis Quote](#)

# BenchChem

Our mission is to be the trusted global source of essential and advanced chemicals, empowering scientists and researchers to drive progress in science and industry.

## Contact

Address: 3281 E Guasti Rd

Ontario, CA 91761, United States

Phone: (601) 213-4426

Email: [info@benchchem.com](mailto:info@benchchem.com)

[Contact our Ph.D. Support Team for a compatibility check](#)