

# Physicochemical Properties of Lenalidomide-6-F: An In-Depth Technical Guide

**Author:** BenchChem Technical Support Team. **Date:** April 2026

## Compound of Interest

Compound Name: *Lenalidomide-6-F*

Cat. No.: *B15543292*

[Get Quote](#)

For Researchers, Scientists, and Drug Development Professionals

## Introduction

**Lenalidomide-6-F** is a fluorinated derivative of Lenalidomide, a well-established immunomodulatory drug. Like its parent compound, **Lenalidomide-6-F** is a ligand for the Cereblon (CRBN) E3 ubiquitin ligase, designed to induce the degradation of specific target proteins. This mechanism of action places it in the class of molecular glues and targeted protein degraders, a rapidly evolving area of drug discovery. Understanding the physicochemical properties of **Lenalidomide-6-F** is critical for its development as a potential therapeutic agent, influencing its solubility, permeability, metabolic stability, and ultimately, its pharmacokinetic and pharmacodynamic profile. This technical guide provides a comprehensive overview of the known physicochemical properties of **Lenalidomide-6-F**, detailed experimental protocols for their determination, and a summary of the relevant biological signaling pathways.

## Core Physicochemical Properties

A thorough literature search reveals limited experimentally determined physicochemical data for **Lenalidomide-6-F**. The available information, primarily from chemical suppliers and computational predictions, is summarized below. For comparison, experimental data for the

parent compound, Lenalidomide, are also included where available, as they provide a valuable reference point.

## **Table 1: Summary of Physicochemical Properties of Lenalidomide-6-F**

Property	Lenalidomide-6-F	Lenalidomide (for reference)	Data Source
Molecular Formula	C <sub>13</sub> H <sub>11</sub> FN <sub>2</sub> O <sub>3</sub> [1][2]	C <sub>13</sub> H <sub>13</sub> N <sub>3</sub> O <sub>3</sub> [3]	Vendor Data
Molecular Weight (g/mol)	262.24[1][2]	259.26[4]	Vendor Data
CAS Number	2468780-87-0[1][2]	191732-72-6[3]	Vendor Data
Appearance	Solid. Color has been described as gray to gray-purple.	Off-white to pale-yellow solid powder.[4]	Vendor Data
Melting Point (°C)	Data not available	269 - 271	Literature
Calculated LogP	0.5867	0.3	Computational
Topological Polar Surface Area (TPSA) (Å <sup>2</sup> )	66.48	95.5	Computational
Hydrogen Bond Donors	1	2	Computational
Hydrogen Bond Acceptors	3	5	Computational
Rotatable Bonds	1	1	Computational
Solubility	≥ 2.5 mg/mL (9.53 mM) in a DMSO/PEG300/Tween-80/saline formulation.[5]	Soluble in organic solvent/water mixtures and buffered aqueous solvents. More soluble in organic solvents and low pH solutions. Solubility in less acidic buffers is about 0.4 to 0.5 mg/mL.[4][6]	Vendor Formulation Data / Literature
pKa	Data not available	2.9 (acidic), 10.9 (basic)	Predicted

---

Stability	Powder: -20°C for 3 years; In solvent: -80°C for 1 year.[1]	Stable in hot water (55°C) for 24 hours.[7] Stable in human plasma.[8]	Vendor Data / Literature
-----------	---	---	--------------------------

---

## Experimental Protocols

To address the gap in experimental data for **Lenalidomide-6-F**, the following section provides detailed, standardized protocols for determining key physicochemical properties. These methods are widely applicable to small molecule drug candidates.

### Determination of Aqueous Solubility (Shake-Flask Method)

Objective: To determine the equilibrium solubility of **Lenalidomide-6-F** in an aqueous buffer (e.g., phosphate-buffered saline, pH 7.4).

Methodology:

- Preparation of Saturated Solution:
  - Add an excess amount of **Lenalidomide-6-F** powder to a known volume of aqueous buffer (e.g., pH 7.4 PBS) in a sealed, clear glass vial. The excess solid should be clearly visible.
- Equilibration:
  - Agitate the vial at a constant temperature (e.g., 25°C or 37°C) using a shaker or rotator for a sufficient period to reach equilibrium (typically 24-48 hours).
- Phase Separation:
  - After equilibration, allow the suspension to stand undisturbed for a short period to allow the undissolved solid to settle.
  - Carefully withdraw an aliquot of the supernatant, ensuring no solid particles are transferred. Centrifuge or filter the aliquot (using a filter compatible with the compound, e.g., PTFE) to remove any remaining microparticulates.

- Quantification:
  - Dilute the clear supernatant with a suitable solvent to a concentration within the linear range of a pre-validated analytical method (e.g., HPLC-UV or LC-MS/MS).
  - Quantify the concentration of **Lenalidomide-6-F** in the diluted sample against a standard curve of known concentrations.
- Calculation:
  - Calculate the solubility by multiplying the measured concentration by the dilution factor. The result is typically expressed in mg/mL or  $\mu\text{M}$ .

## Determination of pKa (Potentiometric Titration)

Objective: To determine the acid dissociation constant(s) (pKa) of **Lenalidomide-6-F**.

Methodology:

- Sample Preparation:
  - Accurately weigh a sample of **Lenalidomide-6-F** and dissolve it in a suitable co-solvent (e.g., methanol or DMSO) if necessary, and then dilute with deionized water. The final concentration should be in the range of 1-10 mM.
- Titration Setup:
  - Use a calibrated pH meter with a suitable electrode and an automated titrator.
  - Place the sample solution in a thermostatted vessel (e.g., at 25°C) and stir continuously.
- Titration:
  - Titrate the solution with a standardized solution of a strong acid (e.g., 0.1 M HCl) and a strong base (e.g., 0.1 M NaOH).
  - Record the pH of the solution as a function of the volume of titrant added.
- Data Analysis:

- Plot the pH versus the volume of titrant added to generate a titration curve.
- The pKa value(s) can be determined from the midpoint(s) of the buffer region(s) of the titration curve, where the pH is equal to the pKa. Alternatively, the pKa can be calculated from the first derivative of the titration curve.

## Determination of Lipophilicity (LogP/LogD)

Objective: To determine the octanol-water partition coefficient (LogP) for the neutral form and the distribution coefficient (LogD) at a specific pH (e.g., 7.4).

Methodology (Shake-Flask Method):

- System Preparation:
  - Pre-saturate n-octanol with the aqueous buffer (e.g., pH 7.4 PBS) and vice versa by mixing and allowing them to separate.
- Partitioning:
  - Prepare a solution of **Lenalidomide-6-F** in the aqueous buffer at a known concentration.
  - Add a known volume of this solution to a vial containing a known volume of the pre-saturated n-octanol.
  - Seal the vial and shake vigorously for a set period (e.g., 1-2 hours) at a constant temperature to allow for partitioning.
- Phase Separation:
  - Centrifuge the vial to ensure complete separation of the octanol and aqueous phases.
- Quantification:
  - Carefully remove an aliquot from both the aqueous and octanol phases.
  - Determine the concentration of **Lenalidomide-6-F** in each phase using a suitable analytical method (e.g., HPLC-UV).

- Calculation:
  - LogP (for the neutral species) or LogD (at a specific pH) is calculated as the base-10 logarithm of the ratio of the concentration in the octanol phase to the concentration in the aqueous phase:  $\text{LogD} = \log_{10} ([\text{Compound}]_{\text{octanol}} / [\text{Compound}]_{\text{aqueous}})$

## Determination of Melting Point (Capillary Method)

Objective: To determine the melting point of **Lenalidomide-6-F**.

Methodology:

- Sample Preparation:
  - Ensure the **Lenalidomide-6-F** sample is a fine, dry powder.
  - Pack a small amount of the powder into a capillary tube, typically to a height of 2-3 mm.
- Measurement:
  - Place the capillary tube in a melting point apparatus.
  - Heat the sample at a controlled rate (e.g., 1-2 °C/min) near the expected melting point.
- Observation:
  - Record the temperature at which the first drop of liquid appears (onset of melting) and the temperature at which the last solid particle melts (completion of melting). The melting point is reported as this range.

## Biological Signaling Pathways

**Lenalidomide-6-F**, as a derivative of Lenalidomide, is designed to function as a molecular glue that hijacks the Cereblon (CRBN) E3 ubiquitin ligase complex. This leads to the ubiquitination and subsequent proteasomal degradation of specific "neosubstrate" proteins.

## Mechanism of Action: CRL4<sup>CRBN</sup> E3 Ubiquitin Ligase Complex

The canonical mechanism involves **Lenalidomide-6-F** binding to the substrate receptor CRBN, which is part of the CULLIN4-RING E3 ubiquitin ligase (CRL4) complex. This binding alters the substrate specificity of CRBN, enabling it to recognize and bind to neosubstrates that it would not normally interact with. This leads to the polyubiquitination of the neosubstrate, marking it for degradation by the 26S proteasome.

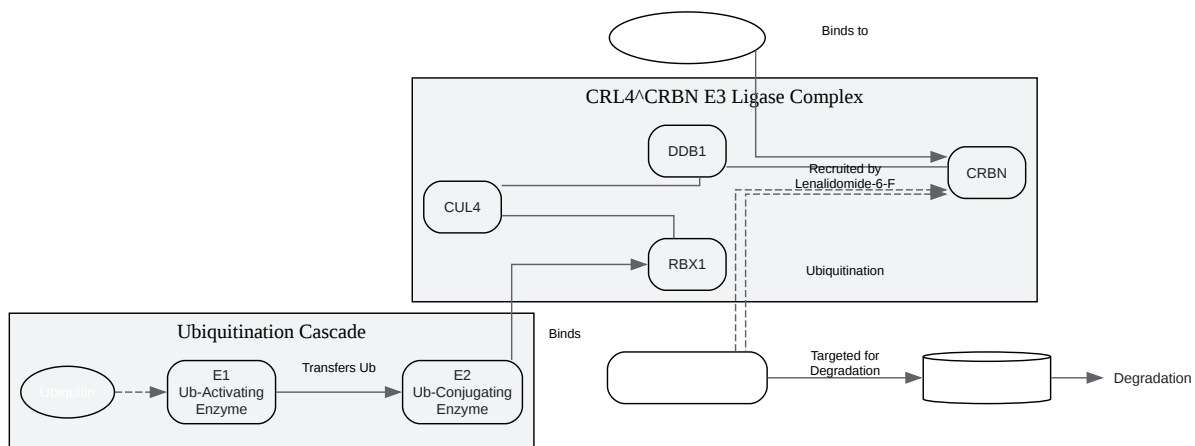

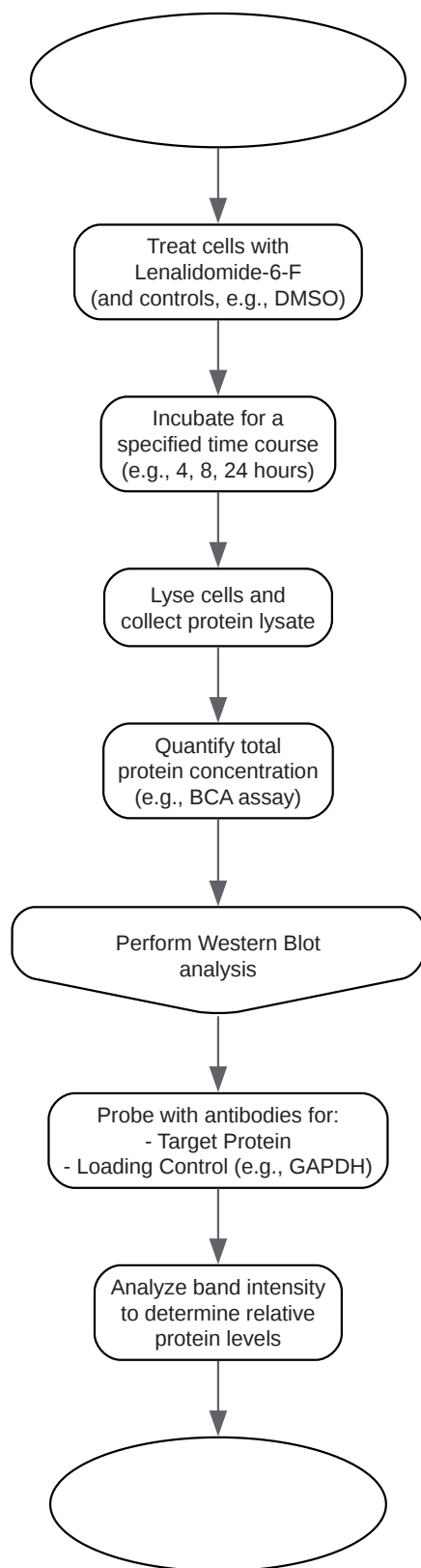

[Click to download full resolution via product page](#)

**Need Custom Synthesis?**

BenchChem offers custom synthesis for rare earth carbides and specific isotopic labeling.

Email: [info@benchchem.com](mailto:info@benchchem.com) or [Request Quote Online](#).

## References

- [1. Lenalidomide-6-F | TargetMol \[targetmol.com\]](#)
- [2. chemscene.com \[chemscene.com\]](#)
- [3. cdn.caymanchem.com \[cdn.caymanchem.com\]](#)
- [4. medkoo.com \[medkoo.com\]](#)
- [5. medchemexpress.cn \[medchemexpress.cn\]](#)
- [6. Lenalidomide | C13H13N3O3 | CID 216326 - PubChem \[pubchem.ncbi.nlm.nih.gov\]](#)
- [7. Stability of lenalidomide suspension after preparation by a simple suspension method for enteral tube administration - PubMed \[pubmed.ncbi.nlm.nih.gov\]](#)
- [8. researchgate.net \[researchgate.net\]](#)
- To cite this document: BenchChem. [Physicochemical Properties of Lenalidomide-6-F: An In-Depth Technical Guide]. BenchChem, [2026]. [Online PDF]. Available at: [\[https://www.benchchem.com/product/b15543292/docs#physicochemical-properties-of-lenalidomide-6-f-an-in-depth-technical-guide\]](https://www.benchchem.com/product/b15543292/docs#physicochemical-properties-of-lenalidomide-6-f-an-in-depth-technical-guide)

---

### Disclaimer & Data Validity:

The information provided in this document is for Research Use Only (RUO) and is strictly not intended for diagnostic or therapeutic procedures. While BenchChem strives to provide accurate protocols, we make no warranties, express or implied, regarding the fitness of this product for every specific experimental setup.

**Technical Support:** The protocols provided are for reference purposes. Unsure if this reagent suits your experiment?

**Need Industrial/Bulk Grade?** [Request Custom Synthesis Quote](#)

# BenchChem

Our mission is to be the trusted global source of essential and advanced chemicals, empowering scientists and researchers to drive progress in science and industry.

## Contact

Address: 3281 E Guasti Rd

Ontario, CA 91761, United States

Phone: (601) 213-4426

Email: [info@benchchem.com](mailto:info@benchchem.com)

[Contact our Ph.D. Support Team for a compatibility check](#)