

Determining Pralsetinib IC50 Values Using an MTT Assay: Application Notes and Protocols

Author: BenchChem Technical Support Team. **Date:** April 2026

Compound of Interest

Compound Name: *Pralsetinib*
CAS No.: 2097132-94-8
Cat. No.: B15543395

[Get Quote](#)

For Researchers, Scientists, and Drug Development Professionals

Abstract

Pralsetinib is a potent and selective inhibitor of the rearranged during transfection (RET) receptor tyrosine kinase, which is aberrantly activated in various cancers.[1][2] Determining the half-maximal inhibitory concentration (IC50) is a critical step in evaluating the efficacy of **Pralsetinib** against cancer cells harboring RET alterations. The MTT (3-(4,5-dimethylthiazol-2-yl)-2,5-diphenyltetrazolium bromide) assay is a widely used colorimetric method to assess cell viability and proliferation, providing a quantitative measure of a drug's cytotoxic or cytostatic effects.[3] This document provides a detailed protocol for determining the IC50 value of **Pralsetinib** in relevant cancer cell lines using the MTT assay.

Introduction

The RET proto-oncogene encodes a receptor tyrosine kinase that, upon binding to its ligands, activates several downstream signaling pathways crucial for cell growth, differentiation, and survival.[4][5] Genetic alterations such as gene fusions (e.g., KIF5B-RET, CCDC6-RET) and activating point mutations can lead to constitutive, ligand-independent activation of the RET

kinase.[1][4] This aberrant signaling drives oncogenesis in various malignancies, including non-small cell lung cancer (NSCLC) and medullary thyroid cancer (MTC).[4]

Pralsetinib selectively targets and inhibits the RET kinase by binding to its ATP-binding site, thereby blocking the phosphorylation of RET and the subsequent activation of downstream signaling cascades like the MAPK/ERK, PI3K/AKT, and JAK/STAT pathways.[1][6] This inhibition ultimately hampers the proliferation and survival of cancer cells driven by RET alterations.[1]

The MTT assay is a reliable method for quantifying the in vitro potency of **Pralsetinib**. The principle of this assay lies in the ability of mitochondrial dehydrogenases in living cells to reduce the yellow tetrazolium salt MTT to a purple formazan product.[7] The amount of formazan produced is directly proportional to the number of viable, metabolically active cells.[8] By measuring the absorbance of the dissolved formazan, the effect of different concentrations of **Pralsetinib** on cell viability can be determined, and the IC50 value can be calculated.

Pralsetinib Signaling Pathway

Constitutively active RET fusion proteins or mutant RET receptors trigger a cascade of intracellular signaling events. The primary pathways implicated in RET-driven cancers are the Ras/Raf/MEK/ERK (MAPK) pathway and the Phosphoinositide 3-kinase (PI3K)/AKT pathway. [4][5] Activation of these pathways leads to uncontrolled cell proliferation and survival.

Pralsetinib acts as a potent inhibitor of this aberrant signaling.

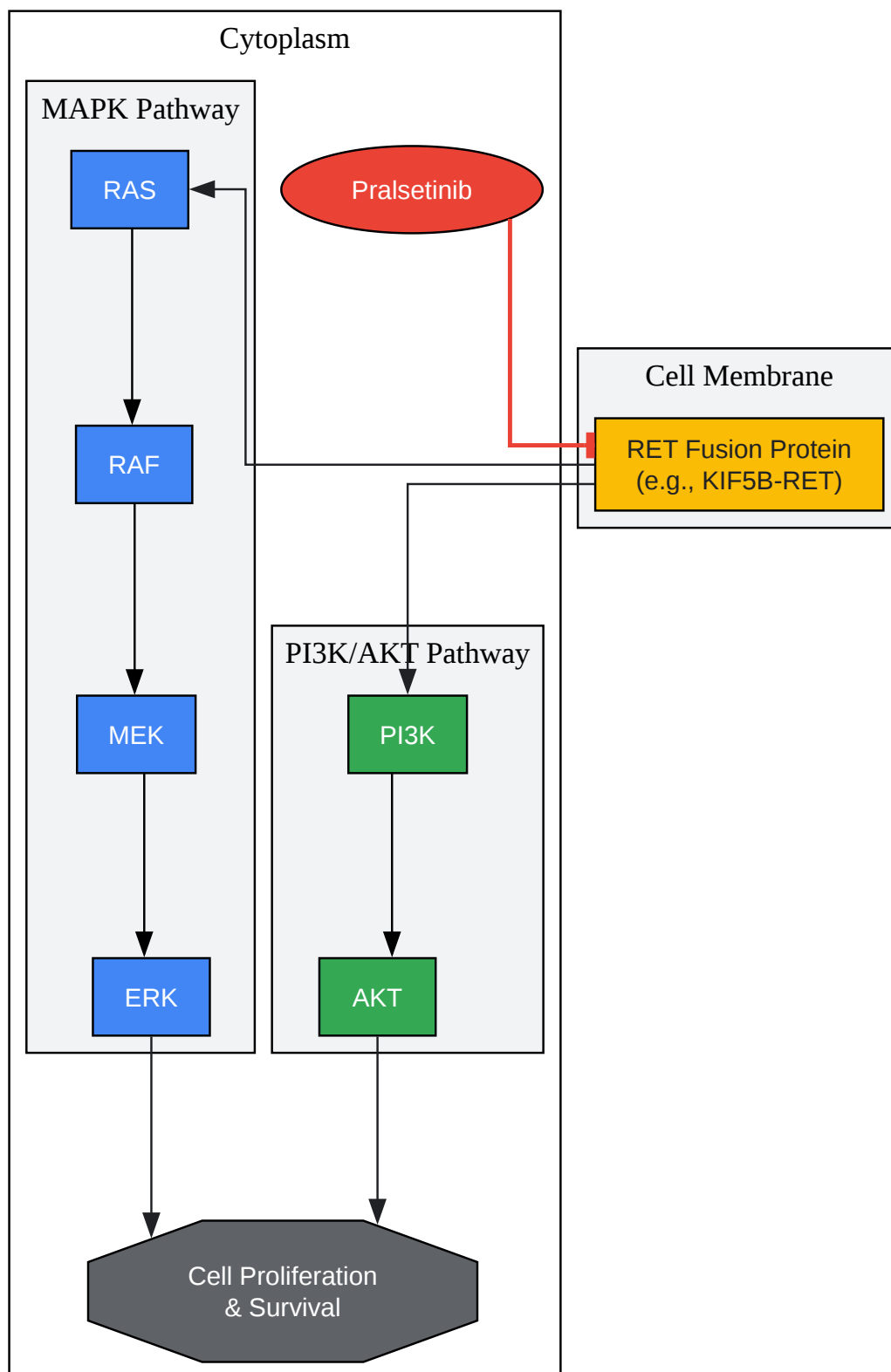

[Click to download full resolution via product page](#)

Pralsetinib inhibits the aberrant RET signaling pathway.

Experimental Protocol: MTT Assay for Pralsetinib IC50 Determination

This protocol outlines the steps for determining the IC50 value of **Pralsetinib** on adherent cancer cell lines with known RET alterations.

Materials and Reagents:

- **Pralsetinib** (powder)
- Dimethyl sulfoxide (DMSO)
- Cancer cell line with RET fusion (e.g., TPC-1, LC-2/ad)
- Complete cell culture medium (e.g., RPMI-1640 with 10% FBS and 1% Penicillin-Streptomycin)
- Phosphate-Buffered Saline (PBS), sterile
- Trypsin-EDTA (0.25%)
- MTT (3-(4,5-dimethylthiazol-2-yl)-2,5-diphenyltetrazolium bromide) solution (5 mg/mL in sterile PBS)
- Solubilization solution (e.g., DMSO or 0.01 M HCl in isopropanol)
- 96-well flat-bottom sterile cell culture plates
- Multichannel pipette
- Microplate reader (capable of measuring absorbance at 570 nm)
- Humidified incubator (37°C, 5% CO₂)

Experimental Workflow:

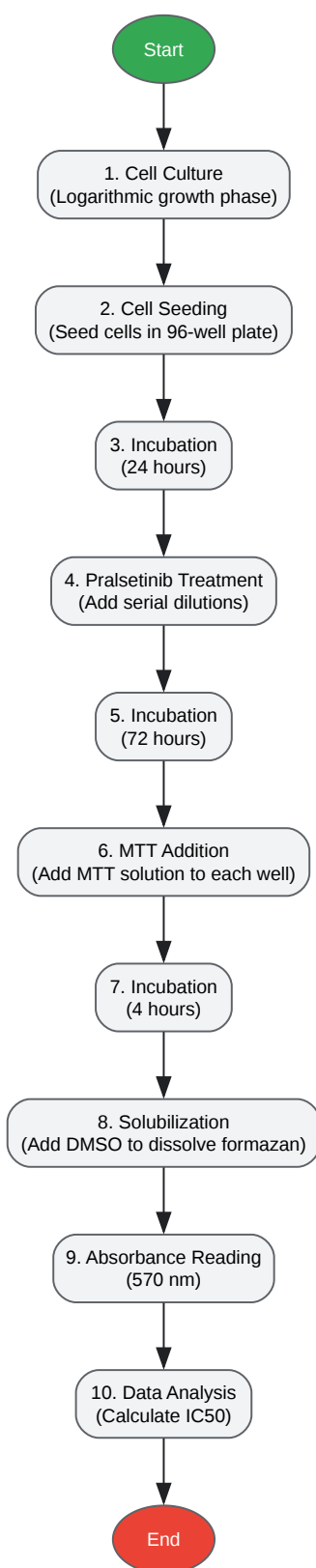

[Click to download full resolution via product page](#)

Workflow for determining **Pralsetinib** IC50 using the MTT assay.

Procedure:

- Preparation of **Pralsetinib** Stock Solution:
 - Dissolve **Pralsetinib** powder in DMSO to prepare a high-concentration stock solution (e.g., 10 mM).
 - Store the stock solution in aliquots at -20°C.
- Cell Culture and Seeding:
 - Culture the selected cancer cell line in complete medium in a humidified incubator at 37°C with 5% CO₂.
 - Ensure cells are in the logarithmic growth phase before starting the experiment.
 - Harvest the cells using trypsin-EDTA, resuspend in fresh complete medium, and perform a cell count.
 - Seed the cells into a 96-well plate at an optimized density (e.g., 5,000-10,000 cells/well in 100 µL of medium).
 - Include wells with medium only to serve as a blank control.
 - Incubate the plate for 24 hours to allow cells to adhere.
- **Pralsetinib** Treatment:
 - Prepare serial dilutions of **Pralsetinib** from the stock solution in complete medium. A common concentration range to test is 0.01 nM to 10 µM.
 - Include a vehicle control (medium with the same concentration of DMSO as the highest **Pralsetinib** concentration).
 - Carefully remove the medium from the wells and add 100 µL of the prepared **Pralsetinib** dilutions to the respective wells. Each concentration should be tested in triplicate.
 - Incubate the plate for 72 hours.

- MTT Assay:
 - After the 72-hour incubation, add 20 µL of 5 mg/mL MTT solution to each well.[7]
 - Incubate the plate for an additional 4 hours at 37°C. During this time, viable cells will convert the MTT into purple formazan crystals.
 - Carefully aspirate the medium containing MTT from each well without disturbing the formazan crystals.
 - Add 150 µL of DMSO to each well to dissolve the formazan crystals.[7]
 - Gently shake the plate on an orbital shaker for 15 minutes to ensure complete dissolution of the formazan.
- Data Acquisition and Analysis:
 - Measure the absorbance of each well at 570 nm using a microplate reader.
 - Calculate the percentage of cell viability for each **Pralsetinib** concentration using the following formula:
 - $\% \text{ Cell Viability} = \frac{[(\text{Absorbance of treated cells} - \text{Absorbance of blank}) / (\text{Absorbance of vehicle control} - \text{Absorbance of blank})] \times 100}$
 - Plot the percentage of cell viability against the log-transformed concentrations of **Pralsetinib**.
 - Use a non-linear regression analysis (sigmoidal dose-response curve) to determine the IC50 value, which is the concentration of **Pralsetinib** that inhibits cell viability by 50%.[9]

Data Presentation

The IC50 values of **Pralsetinib** can vary depending on the cell line and the specific RET alteration. The following table provides a summary of reported IC50 values for **Pralsetinib** in different cancer cell lines.

Cell Line	Cancer Type	RET Alteration	Reported IC50 (nM)
Ba/F3	Pro-B	KIF5B-RET	6
Ba/F3	Pro-B	CCDC6-RET	7
TT	Medullary Thyroid Carcinoma	RET C634W	0.5
MZ-CRC-1	Medullary Thyroid Carcinoma	RET M918T	<1
LC-2/ad	Non-Small Cell Lung Cancer	CCDC6-RET	1.8

Note: The IC50 values presented are examples and can vary between experiments and laboratories due to differences in experimental conditions.[6]

Conclusion

The MTT assay is a robust and reliable method for determining the IC50 value of **Pralsetinib**, providing valuable insights into its potency against cancer cells with specific RET alterations. This detailed protocol and the accompanying information serve as a comprehensive guide for researchers in the field of oncology and drug development to effectively evaluate the efficacy of **Pralsetinib** in a preclinical setting. Consistent and accurate determination of IC50 values is essential for the continued development and clinical application of targeted therapies like **Pralsetinib**.

Need Custom Synthesis?

BenchChem offers custom synthesis for rare earth carbides and specific isotopic labeling.

Email: info@benchchem.com or [Request Quote Online](#).

References

- 1. [What is the mechanism of Pralsetinib? \[synapse.patsnap.com\]](#)
- 2. [Pralsetinib - PubChem \[pubchem.ncbi.nlm.nih.gov\]](#)

- [3. Cytotoxicity MTT Assay Protocols and Methods | Springer Nature Experiments \[experiments.springernature.com\]](#)
- [4. benchchem.com \[benchchem.com\]](#)
- [5. RET signaling pathway and RET inhibitors in human cancer - PMC \[pmc.ncbi.nlm.nih.gov\]](#)
- [6. benchchem.com \[benchchem.com\]](#)
- [7. Protocol for Determining the IC50 of Drugs on Adherent Cells Using MTT Assay - Creative Bioarray | Creative Bioarray \[creative-bioarray.com\]](#)
- [8. merckmillipore.com \[merckmillipore.com\]](#)
- [9. researchgate.net \[researchgate.net\]](#)
- To cite this document: BenchChem. [Determining Pralsetinib IC50 Values Using an MTT Assay: Application Notes and Protocols]. BenchChem, [2026]. [Online PDF]. Available at: [\[https://www.benchchem.com/product/b15543395/docs#determining-pralsetinib-ic50-values-using-an-mtt-assay-application-notes-and-protocols\]](https://www.benchchem.com/product/b15543395/docs#determining-pralsetinib-ic50-values-using-an-mtt-assay-application-notes-and-protocols)

Disclaimer & Data Validity:

The information provided in this document is for Research Use Only (RUO) and is strictly not intended for diagnostic or therapeutic procedures. While BenchChem strives to provide accurate protocols, we make no warranties, express or implied, regarding the fitness of this product for every specific experimental setup.

Technical Support: The protocols provided are for reference purposes. Unsure if this reagent suits your experiment?

Need Industrial/Bulk Grade? [Request Custom Synthesis Quote](#)

BenchChem

Our mission is to be the trusted global source of essential and advanced chemicals, empowering scientists and researchers to drive progress in science and industry.

Contact

Address: 3281 E Guasti Rd
Ontario, CA 91761, United States
Phone: (601) 213-4426
Email: info@benchchem.com

Contact our Ph.D. Support Team for a compatibility check