

# Cell viability issues with MRT-83 treatment

**Author:** BenchChem Technical Support Team. **Date:** April 2026

## Compound of Interest

Compound Name: MRT-83  
Cat. No.: B15543520

[Get Quote](#)

## Technical Support Center: MRT-83 Treatment

This technical support center provides troubleshooting guidance and frequently asked questions for researchers encountering cell viability issues during experiments with **MRT-83**.

### Troubleshooting Guides

Researchers using **MRT-83** may encounter unexpected effects on cell viability. The following table summarizes common issues, their potential causes, and recommended solutions.

Issue	Potential Cause	Recommended Solution
Reduced Cell Viability at Expected Non-Toxic Doses	<p>1. Off-Target Effects: MRT-83, while targeting the Hedgehog signaling pathway, may have unintended effects on other cellular pathways crucial for survival. 2. Solvent Toxicity: The solvent used to dissolve MRT-83 (e.g., DMSO) may be at a cytotoxic concentration. 3. Cell Line Sensitivity: The specific cell line being used may be particularly sensitive to perturbations in the Hedgehog pathway or to the compound itself. 4. Incorrect Compound Concentration: Errors in dilution calculations can lead to higher-than-intended concentrations of MRT-83.</p>	<p>1. Perform Dose-Response Curve: Conduct a comprehensive dose-response experiment to determine the precise IC50 value for your cell line. 2. Vehicle Control: Always include a vehicle-only control (the solvent used for MRT-83) at the same final concentration used in the experimental wells. 3. Test Alternative Cell Lines: If possible, test the effect of MRT-83 on a different cell line to determine if the observed toxicity is cell-type specific. 4. Verify Concentration: Double-check all dilution calculations and ensure the stock solution concentration is accurate.</p>
Inconsistent Results Between Experiments	<p>1. Cell Passage Number: Cells at high passage numbers can exhibit altered growth rates and drug sensitivities. 2. Inconsistent Seeding Density: Variations in the initial number of cells seeded can lead to variability in the final viability readout. 3. Compound Degradation: Improper storage of MRT-83 stock solutions can lead to loss of potency. 4. Assay Variability: Different viability assays measure different cellular parameters (e.g., metabolic activity vs.</p>	<p>1. Use Low-Passage Cells: Maintain a consistent and low passage number for your cell lines. 2. Optimize Seeding Density: Ensure a uniform single-cell suspension and consistent seeding density across all wells and experiments. 3. Proper Compound Storage: Aliquot and store MRT-83 stock solutions at the recommended temperature and protect from light. 4. Use Orthogonal Assays: Confirm viability results with a second,</p>

	membrane integrity) and can yield different results.	mechanistically different assay (e.g., an ATP-based assay in addition to an MTT assay).
High Background Signal in Viability Assay	<p>1. Compound Interference: MRT-83 may directly react with the assay reagent (e.g., reducing MTT to formazan).</p> <p>2. Media Components: Phenol red or other components in the culture medium can interfere with absorbance or fluorescence readings.</p> <p>3. Contamination: Microbial contamination can lead to false signals in metabolic assays.</p>	<p>1. Include Compound-Only Control: Test for direct interaction by adding MRT-83 to cell-free media with the assay reagent.</p> <p>2. Use Phenol Red-Free Media: For colorimetric or fluorescent assays, consider using phenol red-free medium during the assay incubation period.</p> <p>3. Microbial Contamination Check: Regularly check cell cultures for any signs of contamination.</p>

## Frequently Asked Questions (FAQs)

Q1: What is the mechanism of action of **MRT-83**?

A1: **MRT-83** is a potent antagonist of the Smoothed (Smo) receptor, a key component of the Hedgehog (Hh) signaling pathway.<sup>[1]</sup> By inhibiting Smo, **MRT-83** blocks the downstream signaling cascade that is often aberrantly activated in certain types of cancer.<sup>[1]</sup>

Q2: My cell viability results with **MRT-83** are not what I expected. What are some common pitfalls with viability assays?

A2: Inconsistent results in cell viability assays can arise from several factors, including direct interference of the compound with the assay reagents, effects on cellular metabolism that alter the assay readout, or inherent cytotoxicity that varies with experimental conditions.<sup>[2]</sup> It's also possible for different viability assays to produce conflicting results for the same compound.<sup>[2]</sup>

Q3: Can **MRT-83** directly interfere with common viability assay reagents like MTT or resazurin?

A3: While specific data for **MRT-83** is not available, compounds can have reducing potential and directly reduce tetrazolium salts (like MTT) or resazurin, leading to a false positive signal of higher viability.[2] Conversely, some compounds might inhibit the enzymes responsible for reducing these dyes, causing an underestimation of viability.[2]

Q4: How does the choice of viability assay impact the interpretation of **MRT-83**'s effects?

A4: Many viability assays, such as those using MTT, XTT, and resazurin, measure metabolic activity as a proxy for cell viability.[2] If **MRT-83** affects mitochondrial function or the cellular redox state, it could lead to an over- or underestimation of viability that is not directly correlated with the number of living cells.[2] Therefore, it is advisable to use a secondary assay that measures a different parameter, such as an ATP-based assay (e.g., CellTiter-Glo®) or a dye-exclusion assay (e.g., Trypan Blue).

Q5: What is the role of the Hedgehog signaling pathway in cell viability?

A5: The Hedgehog signaling pathway plays a crucial role in embryonic development and tissue homeostasis. In some cancers, the pathway is reactivated, promoting cell proliferation and survival. By inhibiting this pathway with antagonists like **MRT-83**, the aim is to reduce the viability of cancer cells that are dependent on this signaling.

## Experimental Protocols

### MTT Cell Viability Assay Protocol

This protocol is for assessing cell viability by measuring the metabolic activity of cells.

- Cell Seeding:
  - Harvest and count cells.
  - Seed cells in a 96-well plate at a predetermined optimal density.
  - Incubate for 24 hours to allow for cell attachment.
- Compound Treatment:
  - Prepare serial dilutions of **MRT-83** in culture medium.

- Remove the old medium from the wells and add the medium containing different concentrations of **MRT-83**.
- Include vehicle-only controls.[2]
- Incubate for the desired time period (e.g., 24, 48, or 72 hours).[2]
- MTT Addition:
  - Prepare a 5 mg/mL stock solution of MTT in sterile PBS.
  - Dilute the stock solution to 0.5 mg/mL in serum-free medium.[2]
  - Remove the treatment medium and add 100  $\mu$ L of the MTT solution to each well.[2]
  - Incubate for 2-4 hours at 37°C.[2]
- Formazan Solubilization:
  - Carefully remove the MTT solution.
  - Add 100  $\mu$ L of a solubilization solution (e.g., DMSO) to each well.[2]
- Absorbance Measurement:
  - Gently shake the plate to ensure complete dissolution of the formazan crystals.
  - Measure the absorbance at 570 nm using a microplate reader.

## ATP-Based Cell Viability Assay (e.g., CellTiter-Glo®) Protocol

This protocol measures cell viability by quantifying ATP, an indicator of metabolically active cells.

- Cell Seeding and Treatment:
  - Follow steps 1 and 2 from the MTT protocol.

- Reagent Preparation:
  - Equilibrate the CellTiter-Glo® reagent to room temperature.
- Assay Procedure:
  - Remove the plate from the incubator and allow it to cool to room temperature for about 30 minutes.
  - Add a volume of CellTiter-Glo® reagent equal to the volume of culture medium in each well.
  - Mix the contents for 2 minutes on an orbital shaker to induce cell lysis.
  - Incubate at room temperature for 10 minutes to stabilize the luminescent signal.
- Luminescence Measurement:
  - Measure the luminescence using a plate-reading luminometer.

## Visualizations

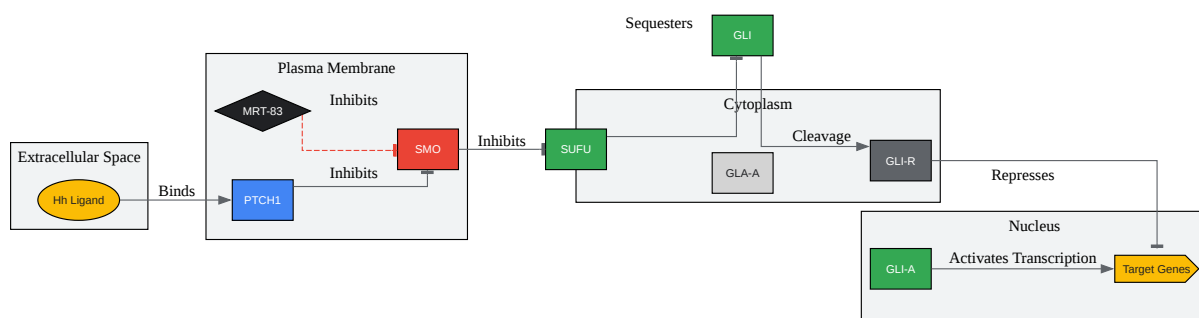

[Click to download full resolution via product page](#)

Caption: Hedgehog signaling pathway with **MRT-83** inhibition.

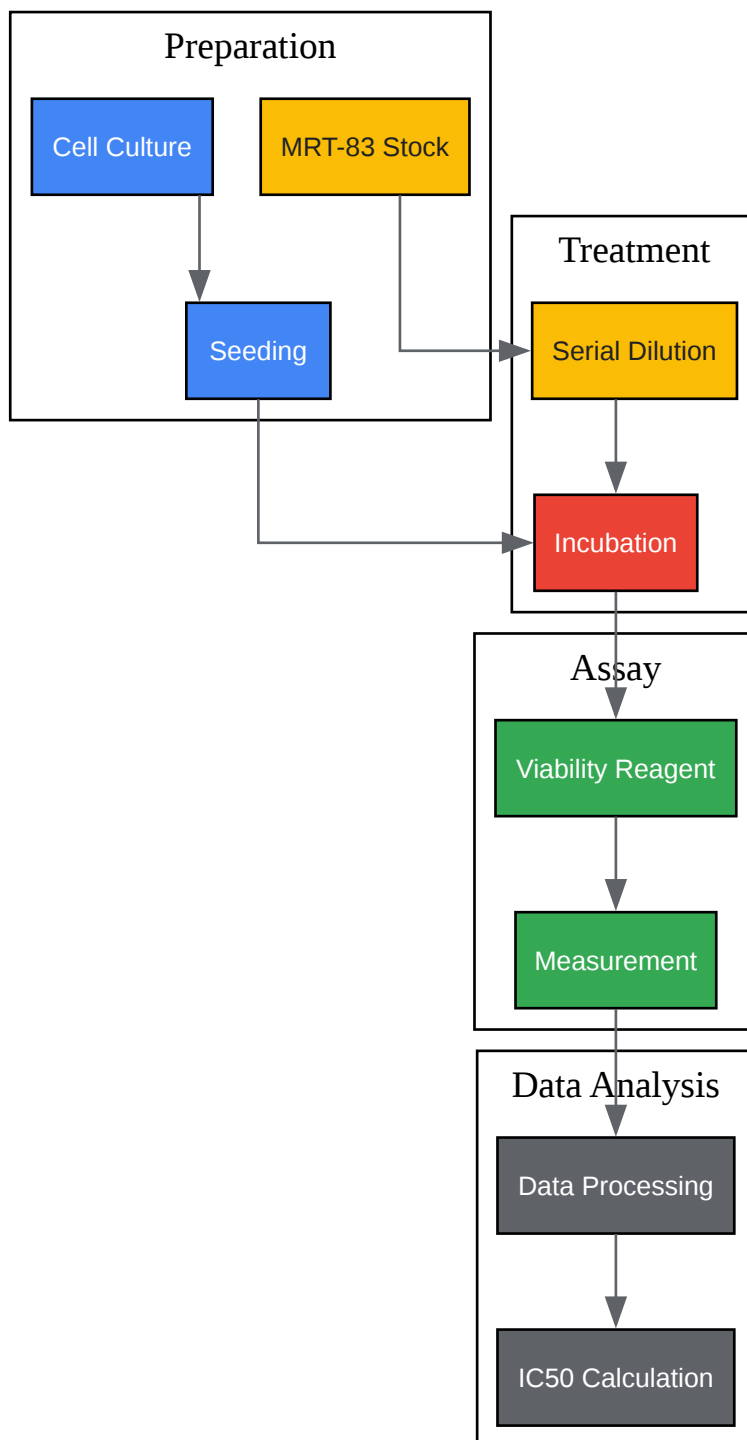

[Click to download full resolution via product page](#)

Caption: Workflow for assessing **MRT-83** cell viability.

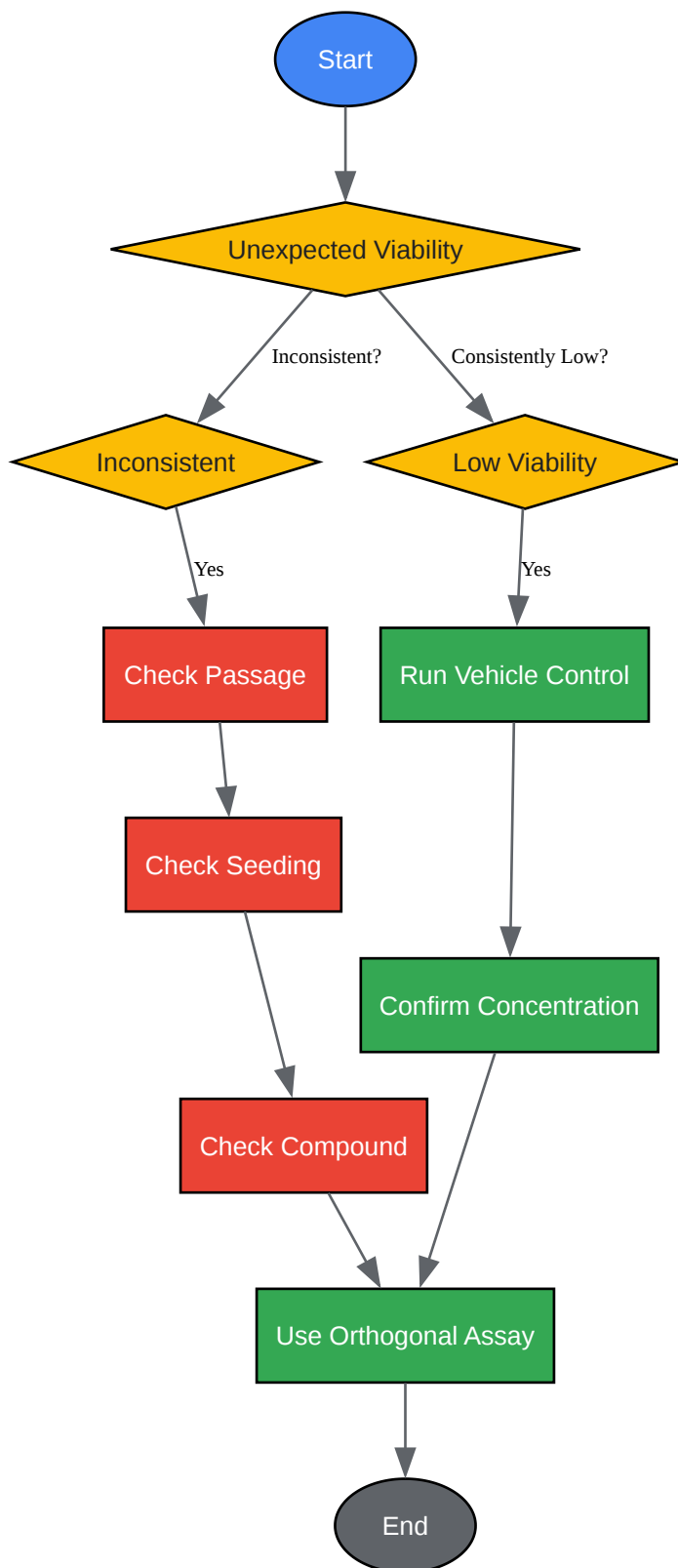

[Click to download full resolution via product page](#)

Caption: Troubleshooting decision tree for viability assays.

### Need Custom Synthesis?

BenchChem offers custom synthesis for rare earth carbides and specific isotopic labeling.

Email: [info@benchchem.com](mailto:info@benchchem.com) or [Request Quote Online](#).

## References

- [1. Identification and mechanism of action of the acylguanidine MRT-83, a novel potent Smoothed antagonist - PubMed \[pubmed.ncbi.nlm.nih.gov\]](#)
- [2. benchchem.com \[benchchem.com\]](#)
- To cite this document: BenchChem. [Cell viability issues with MRT-83 treatment]. BenchChem, [2026]. [Online PDF]. Available at: [\[https://www.benchchem.com/product/b15543520/docs#cell-viability-issues-with-mrt-83-treatment\]](https://www.benchchem.com/product/b15543520/docs#cell-viability-issues-with-mrt-83-treatment)

---

### Disclaimer & Data Validity:

The information provided in this document is for Research Use Only (RUO) and is strictly not intended for diagnostic or therapeutic procedures. While BenchChem strives to provide accurate protocols, we make no warranties, express or implied, regarding the fitness of this product for every specific experimental setup.

**Technical Support:** The protocols provided are for reference purposes. Unsure if this reagent suits your experiment?

**Need Industrial/Bulk Grade?** [Request Custom Synthesis Quote](#)

# BenchChem

Our mission is to be the trusted global source of essential and advanced chemicals, empowering scientists and researchers to drive progress in science and industry.

## Contact

Address: 3281 E Guasti Rd

Ontario, CA 91761, United States

Phone: (601) 213-4426

Email: [info@benchchem.com](mailto:info@benchchem.com)

[Contact our Ph.D. Support Team for a compatibility check](#)