

Application Notes and Protocols for m-PEG2-azide Bioconjugation

Author: BenchChem Technical Support Team. **Date:** April 2026

Compound of Interest

Compound Name: *m*-PEG2-azide

CAS No.: 89485-61-0

Cat. No.: B15543973

[Get Quote](#)

For Researchers, Scientists, and Drug Development Professionals

These application notes provide a detailed guide for the bioconjugation of molecules using **m-PEG2-azide**, a short, hydrophilic linker containing a terminal azide group. This versatile reagent is a cornerstone of "click chemistry," enabling the efficient and specific covalent attachment of the polyethylene glycol (PEG) moiety to biomolecules. The protocols outlined below cover the two most common and powerful azide-alkyne cycloaddition reactions: the copper(I)-catalyzed reaction (CuAAC) and the strain-promoted, copper-free reaction (SPAAC).

[\[1\]](#)[\[2\]](#)

The introduction of a PEG spacer can enhance the solubility, stability, and pharmacokinetic properties of the resulting bioconjugate, making it a valuable tool in drug delivery, diagnostics, and proteomics.[\[3\]](#)

Overview of m-PEG2-azide Bioconjugation Chemistry

m-PEG2-azide participates in highly selective and bioorthogonal cycloaddition reactions with alkyne-containing molecules to form a stable triazole linkage.[1] The choice between the two primary methods, CuAAC and SPAAC, depends on the specific application and the sensitivity of the biomolecule to the reaction conditions.

- **Copper(I)-Catalyzed Azide-Alkyne Cycloaddition (CuAAC):** This highly efficient reaction utilizes a copper(I) catalyst to join a terminal alkyne with an azide.[4] It is known for its rapid kinetics and high yields. However, the copper catalyst can be cytotoxic, making this method more suitable for in vitro applications.[5]
- **Strain-Promoted Azide-Alkyne Cycloaddition (SPAAC):** This is a copper-free click chemistry reaction that relies on the high ring strain of a cyclooctyne to react with an azide.[1][2] The absence of a cytotoxic catalyst makes SPAAC ideal for bioconjugation in living systems and for sensitive biomolecules.[2]

Quantitative Data Summary

The following tables summarize key quantitative parameters for both CuAAC and SPAAC reactions to facilitate experimental design and comparison.

Table 1: Reaction Parameters for **m-PEG2-azide** Bioconjugation

Parameter	Copper-Catalyzed Azide-Alkyne Cycloaddition (CuAAC)	Strain-Promoted Azide-Alkyne Cycloaddition (SPAAC)
Alkyne Partner	Terminal Alkyne	Strained Cyclooctyne (e.g., DBCO, BCN)
m-PEG2-azide Molar Excess	1.1 - 2.0 equivalents	5 - 20 fold molar excess
Copper(I) Source	Copper(II) Sulfate (with reducing agent)	Not Applicable
Copper(II) Sulfate Conc.	0.05 - 1 mM	Not Applicable
Reducing Agent	Sodium Ascorbate (freshly prepared)	Not Applicable
Sodium Ascorbate Conc.	1 - 5 mM (typically 4-10 fold excess over copper)	Not Applicable
Copper Ligand (optional)	e.g., THPTA, TBTA (to stabilize Cu(I) and protect biomolecule)	Not Applicable
Ligand Concentration	0.1 mM (typically 5:1 ligand to copper ratio)	Not Applicable
Reaction Temperature	Room Temperature (can be heated to 40-50°C to increase rate)	4°C to 37°C
Reaction Time	1 - 4 hours	1 - 12 hours (overnight at 4°C is common)
Typical Solvents	Aqueous buffers (e.g., PBS, pH 7.4), DMSO, DMF	Aqueous buffers (e.g., PBS, pH 7.4), DMSO, DMF

Table 2: Second-Order Rate Constants for SPAAC Reactions with Benzyl Azide*

Strained Alkyne	Second-Order Rate Constant ($M^{-1}s^{-1}$)
DBCO	~0.1 - 1.0
BCN	Varies depending on isomer
DIBAC	~0.3

*Note: These values are for benzyl azide and serve as an estimate. The presence of a PEG linker can influence reaction kinetics.

Experimental Protocols

The following are detailed step-by-step protocols for performing CuAAC and SPAAC reactions with **m-PEG2-azide**.

Protocol 1: Copper(I)-Catalyzed Azide-Alkyne Cycloaddition (CuAAC)

This protocol describes the conjugation of **m-PEG2-azide** to a terminal alkyne-modified biomolecule.

Materials:

- Alkyne-modified biomolecule (e.g., protein, peptide)
- **m-PEG2-azide**
- Copper(II) Sulfate ($CuSO_4$)
- Sodium Ascorbate
- Copper Ligand (e.g., THPTA or TBTA) (optional but recommended)
- Reaction Buffer: Phosphate-buffered saline (PBS), pH 7.4, or other amine-free buffer.
- Organic Solvent: Anhydrous Dimethyl sulfoxide (DMSO) or Dimethylformamide (DMF) for dissolving reagents.

- Degassing equipment (e.g., nitrogen or argon gas line)

Experimental Procedure:

- Prepare Stock Solutions:
 - Dissolve the alkyne-modified biomolecule in the reaction buffer to a desired concentration (e.g., 1-10 mg/mL).
 - Prepare a 10-20 mM stock solution of **m-PEG2-azide** in DMSO or DMF.
 - Prepare a 50 mM stock solution of CuSO₄ in deionized water.
 - Immediately before use, prepare a fresh 50 mM stock solution of Sodium Ascorbate in deionized water.
 - If using a ligand, prepare a 10 mM stock solution of the copper ligand in DMSO.
- Reaction Setup:
 - In a reaction tube, add the alkyne-modified biomolecule solution.
 - Add the **m-PEG2-azide** stock solution to achieve the desired molar excess (typically 1.1-2.0 equivalents).
 - If using a ligand, add the stock solution to a final concentration of 0.1 mM.[5]
 - Gently mix the solution.
- Degassing (Crucial Step):
 - Degas the reaction mixture by bubbling with an inert gas (nitrogen or argon) for 15-30 minutes to remove dissolved oxygen, which can oxidize the Cu(I) catalyst.[6]
- Initiate the Reaction:
 - Add the CuSO₄ stock solution to a final concentration of 1 mM.[5]

- Immediately add the freshly prepared Sodium Ascorbate stock solution to a final concentration of 1 mM.[5]
- Gently mix the reaction.
- Incubation:
 - Incubate the reaction at room temperature for 1-4 hours. Protect the reaction from light.[7]
 - Monitor the reaction progress using an appropriate analytical technique (e.g., SDS-PAGE, LC-MS).
- Purification:
 - Once the reaction is complete, purify the **m-PEG2-azide**-conjugated biomolecule to remove excess reagents and catalyst.
 - Common purification methods include size-exclusion chromatography (SEC), ion-exchange chromatography (IEX), or dialysis.

Protocol 2: Strain-Promoted Azide-Alkyne Cycloaddition (SPAAC)

This protocol details the copper-free conjugation of **m-PEG2-azide** to a strained alkyne (e.g., DBCO)-modified biomolecule.

Materials:

- Strained alkyne-modified biomolecule (e.g., DBCO-protein)
- **m-PEG2-azide**
- Reaction Buffer: Phosphate-buffered saline (PBS), pH 7.4, or other suitable amine-free buffer.
- Organic Solvent: Anhydrous Dimethyl sulfoxide (DMSO) or Dimethylformamide (DMF) for dissolving **m-PEG2-azide**.

Experimental Procedure:

- Prepare Stock Solutions:
 - Dissolve the strained alkyne-modified biomolecule in the reaction buffer to a desired concentration (e.g., 1-5 mg/mL).[3]
 - Prepare a 10-20 mM stock solution of **m-PEG2-azide** in DMSO or DMF.
- Reaction Setup:
 - In a reaction tube, add the strained alkyne-modified biomolecule solution.
 - Add the **m-PEG2-azide** stock solution to achieve the desired molar excess (typically 5-20 fold).[3] The final concentration of the organic solvent should be kept low (<10%) to avoid protein denaturation.[3]
 - Gently mix the solution.
- Incubation:
 - Incubate the reaction mixture at room temperature or 37°C for 1-4 hours. Alternatively, the reaction can be performed at 4°C overnight.[3][8]
 - Monitor the reaction progress by an appropriate method (e.g., SDS-PAGE, LC-MS, or by monitoring the disappearance of the DBCO absorbance at ~310 nm).[8]
- Purification:
 - After the reaction is complete, purify the **m-PEG2-azide**-conjugated biomolecule from excess linker.
 - Purification can be achieved using methods such as size-exclusion chromatography (SEC), dialysis, or spin desalting columns.

Characterization of the Bioconjugate

After purification, it is essential to characterize the final bioconjugate to confirm successful conjugation and assess its properties.

Table 3: Common Characterization Techniques

Technique	Purpose
SDS-PAGE	To visualize the increase in molecular weight of the biomolecule after PEGylation.
Mass Spectrometry (e.g., ESI-MS, MALDI-TOF)	To determine the precise molecular weight of the conjugate and confirm the degree of labeling.[9]
HPLC (e.g., RP-HPLC, SEC-HPLC)	To assess the purity of the conjugate and separate it from unreacted starting materials.[9]
UV-Vis Spectroscopy	To quantify the concentration of the biomolecule and, in the case of SPAAC with DBCO, to monitor the reaction progress.[10]
Functional Assays	To ensure that the biological activity of the biomolecule is retained after conjugation.

Troubleshooting

Low yields or incomplete reactions can occur. The following table provides guidance on common issues and potential solutions.

Table 4: Troubleshooting Guide for **m-PEG2-azide** Bioconjugation

Symptom	Potential Cause	Suggested Solution
Low or no yield in CuAAC	Oxidation of Cu(I) catalyst to inactive Cu(II).	Ensure thorough degassing of all solutions. Use a freshly prepared solution of sodium ascorbate. Work under an inert atmosphere.[6]
Poor quality of reagents.	Verify the purity and integrity of m-PEG2-azide and the alkyne-modified biomolecule.	
Presence of chelating agents in the buffer.	Avoid buffers containing EDTA or other strong chelators.	
Low or no yield in SPAAC	Steric hindrance.	Increase reaction temperature, prolong reaction time, or consider a linker with a longer PEG chain.[6]
Hydrolysis of the strained alkyne.	Ensure appropriate pH and storage conditions for the alkyne-modified biomolecule.	
Multiple products observed	Side reactions.	For CuAAC, ensure the use of a stabilizing ligand to protect the biomolecule. For SPAAC, ensure the buffer conditions are optimal to prevent side reactions with the biomolecule.
Difficulty in purification	Aggregation of the conjugate.	The PEG linker should improve solubility, but if aggregation occurs, consider optimizing buffer conditions (e.g., adding mild detergents).

Visualizing the Workflow

The following diagrams illustrate the experimental workflows for CuAAC and SPAAC bioconjugation with **m-PEG2-azide**.

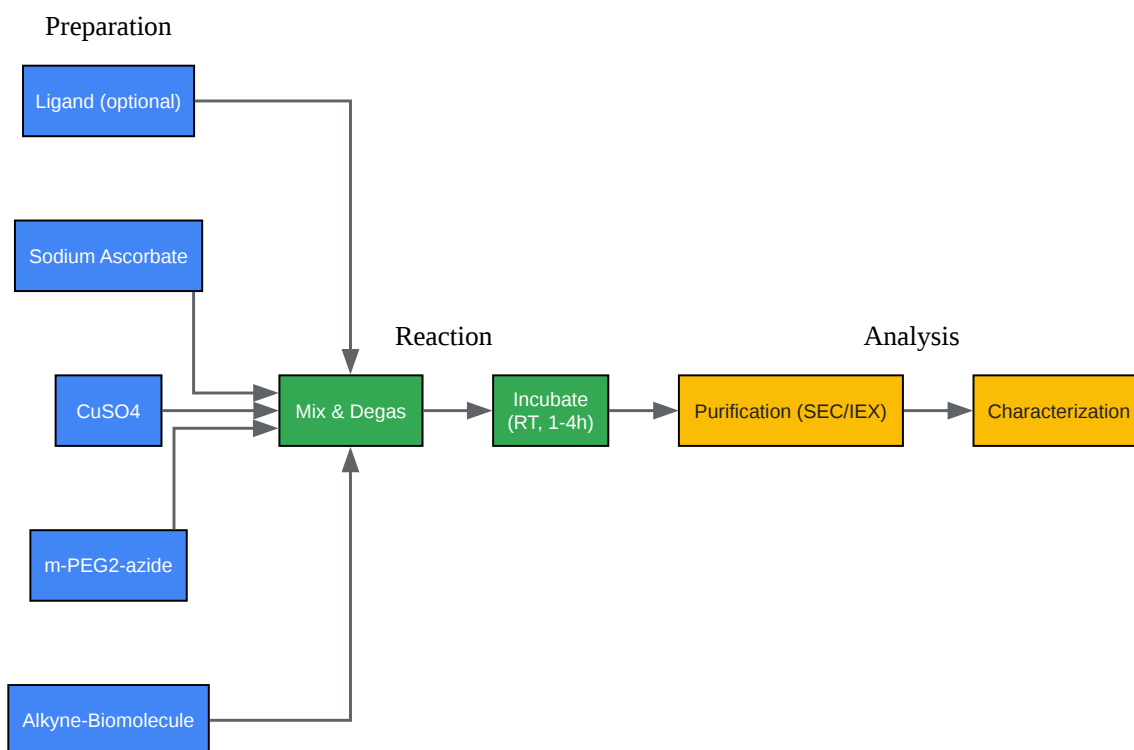

[Click to download full resolution via product page](#)

Caption: Workflow for Copper-Catalyzed Azide-Alkyne Cycloaddition (CuAAC).

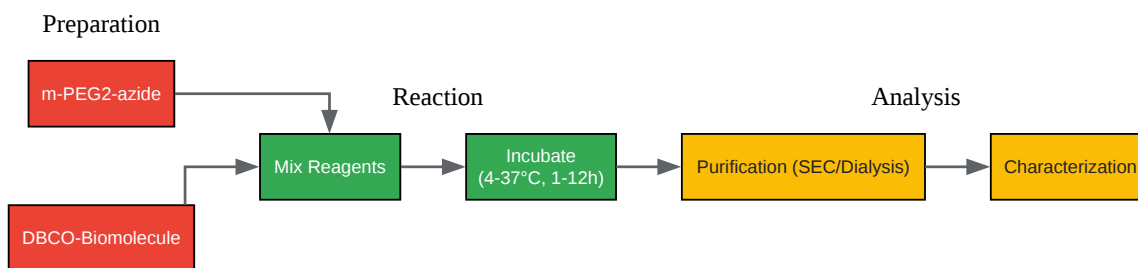

[Click to download full resolution via product page](#)

Caption: Workflow for Strain-Promoted Azide-Alkyne Cycloaddition (SPAAC).

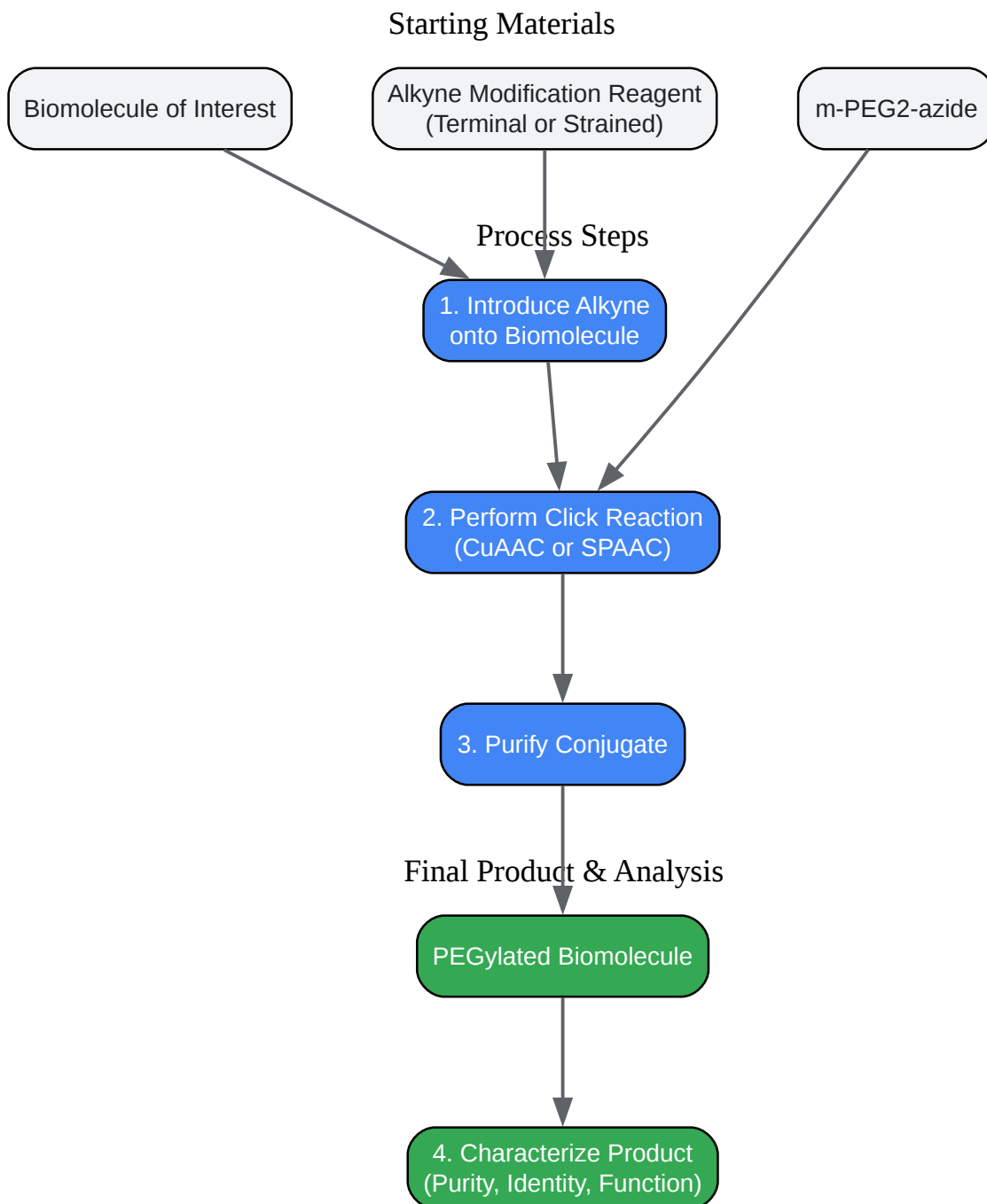

[Click to download full resolution via product page](#)

Need Custom Synthesis?

BenchChem offers custom synthesis for rare earth carbides and specific isotopic labeling.

Email: info@benchchem.com or [Request Quote Online](#).

References

- 1. Practical Considerations, Challenges, and Limitations of Bioconjugation via Azide-Alkyne Cycloaddition - PMC [[pmc.ncbi.nlm.nih.gov](https://pubmed.ncbi.nlm.nih.gov)]
- 2. vectorlabs.com [vectorlabs.com]
- 3. benchchem.com [benchchem.com]
- 4. Bioconjugation by copper(I)-catalyzed azide-alkyne [3 + 2] cycloaddition - PubMed [pubmed.ncbi.nlm.nih.gov]
- 5. benchchem.com [benchchem.com]
- 6. benchchem.com [benchchem.com]
- 7. benchchem.com [benchchem.com]
- 8. docs.aatbio.com [docs.aatbio.com]
- 9. From Synthesis to Characterization of Site-Selective PEGylated Proteins - PMC [[pmc.ncbi.nlm.nih.gov](https://pubmed.ncbi.nlm.nih.gov)]
- 10. d-nb.info [d-nb.info]
- To cite this document: BenchChem. [Application Notes and Protocols for m-PEG2-azide Bioconjugation]. BenchChem, [2026]. [Online PDF]. Available at: [<https://www.benchchem.com/product/b15543973/docs#application-notes-and-protocols-for-m-peg2-azide-bioconjugation>]

Disclaimer & Data Validity:

The information provided in this document is for Research Use Only (RUO) and is strictly not intended for diagnostic or therapeutic procedures. While BenchChem strives to provide accurate protocols, we make no warranties, express or implied, regarding the fitness of this product for every specific experimental setup.

Technical Support: The protocols provided are for reference purposes. Unsure if this reagent suits your experiment?

Need Industrial/Bulk Grade? [Request Custom Synthesis Quote](#)

BenchChem

Our mission is to be the trusted global source of essential and advanced chemicals, empowering scientists and researchers to drive progress in science and industry.

Contact

Address: 3281 E Guasti Rd
Ontario, CA 91761, United States
Phone: (601) 213-4426
Email: info@benchchem.com

[Contact our Ph.D. Support Team for a compatibility check](#)