

A Technical Guide to Bioorthogonal Ligation in Live Cells

Author: BenchChem Technical Support Team. **Date:** April 2026

Compound of Interest

Compound Name: TCO-PEG6-NHS ester

Cat. No.: B15543264

[Get Quote](#)

For Researchers, Scientists, and Drug Development Professionals

Introduction to Bioorthogonal Chemistry

Bioorthogonal chemistry refers to a class of chemical reactions that can occur within living systems without interfering with or being perturbed by the native biochemical processes of the cell.^{[1][2]} Coined by Carolyn R. Bertozzi in 2003, this concept has revolutionized the study of biomolecules in their native environments.^[1] The core principle involves a two-step process: first, a biomolecule of interest is tagged with a "chemical reporter," a small, inert functional group like an azide.^{[1][3]} Second, a probe molecule carrying a complementary functional group is introduced, which then selectively reacts with the reporter in a process called ligation.^[1]

This technology enables the precise labeling, visualization, and manipulation of a wide array of biomolecules—including glycans, proteins, and lipids—in real time and within the complexity of living cells and even whole organisms.^{[1][4][5]} Its applications are vast, ranging from fundamental cell biology and proteomics to the development of targeted drug delivery systems and advanced in vivo imaging techniques.^{[6][7][8][9]}

To be considered truly bioorthogonal, a reaction must meet several stringent criteria^[1]:

- **Selectivity:** The reacting partners must be mutually and exclusively reactive, ignoring the vast array of other functional groups present in a cell.
- **Biocompatibility:** The chemical reporter, the probe, and the resulting linkage must be non-toxic and not disrupt the cell's normal physiology.
- **Kinetics:** The reaction must proceed at a reasonable rate at physiological conditions (temperature, pH, and aqueous environment) and at low, biologically relevant concentrations.
- **Stability:** The reactants and the resulting covalent bond must be stable in the cellular environment.

This guide provides an in-depth overview of the core bioorthogonal ligation reactions, their quantitative characteristics, detailed experimental protocols for their application in live cells, and their use in cutting-edge research and drug development.

Core Principle of Bioorthogonal Labeling

The general workflow of a bioorthogonal labeling experiment involves two key stages, as depicted below.

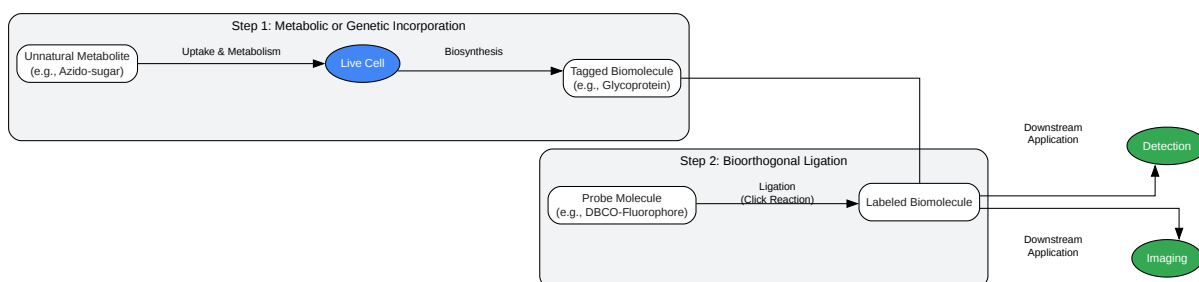

[Click to download full resolution via product page](#)

Caption: General workflow of a two-step bioorthogonal labeling experiment.

Core Bioorthogonal Ligation Reactions

Several distinct chemistries have been developed that meet the criteria for bioorthogonality. The most prominent among these are the Staudinger ligation, Strain-Promoted Alkyne-Azide Cycloaddition (SPAAC), and the Inverse-Electron-Demand Diels-Alder (IEDDA) reaction.

Staudinger Ligation

The Staudinger ligation was one of the first bioorthogonal reactions to be developed for use in living systems.^{[5][10]} It is based on the classic Staudinger reaction between an azide and a phosphine.^{[2][11]} In the bioorthogonal version, the phosphine is engineered with an electrophilic trap (typically a methyl ester) that intercepts the aza-ylide intermediate to form a stable amide bond.^{[10][12]}

While foundational, the Staudinger ligation suffers from relatively slow reaction kinetics and the potential for phosphine oxidation in the cellular environment, which has led to it being largely

superseded by faster "click chemistry" reactions for many applications.[13]

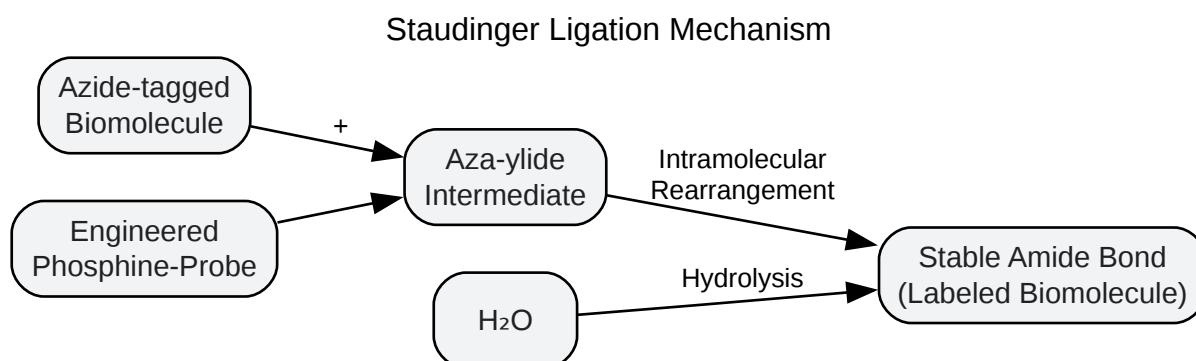

[Click to download full resolution via product page](#)

Caption: Simplified mechanism of the Staudinger Ligation.

Strain-Promoted Alkyne-Azide Cycloaddition (SPAAC)

Strain-Promoted Alkyne-Azide Cycloaddition (SPAAC), also known as copper-free click chemistry, is a cornerstone of bioorthogonal ligation.[14] This reaction involves a [3+2] dipolar cycloaddition between an azide and a strained cyclooctyne to form a stable triazole linkage.[14] [15] The key innovation of SPAAC is the use of ring strain in the cyclooctyne to lower the activation energy of the reaction, thereby eliminating the need for the cytotoxic copper(I) catalyst required in the original "click" reaction (CuAAC).[4][14]

The reaction kinetics of SPAAC are highly dependent on the structure of the cyclooctyne.[14] Significant research has gone into developing cyclooctynes with enhanced reactivity and stability, leading to several generations of reagents.

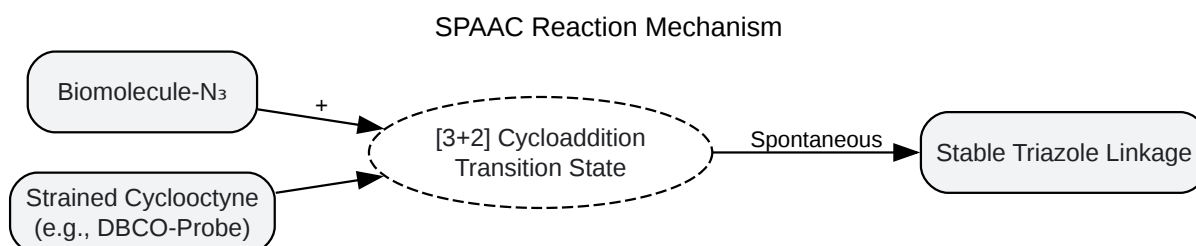

[Click to download full resolution via product page](#)

Caption: Mechanism of Strain-Promoted Alkyne-Azide Cycloaddition (SPAAC).

Inverse-Electron-Demand Diels-Alder (IEDDA) Reaction

The Inverse-Electron-Demand Diels-Alder (IEDDA) reaction is currently the fastest known bioorthogonal reaction, with second-order rate constants that can be several orders of magnitude higher than SPAAC.[1][16][17] This exceptional speed makes it ideal for labeling low-abundance biomolecules and for in vivo applications where rapid clearance of probes is a concern.[18]

The reaction occurs between an electron-poor diene, most commonly a tetrazine, and an electron-rich dienophile, such as a strained trans-cyclooctene (TCO) or norbornene.[16][19][20] The reaction proceeds via a [4+2] cycloaddition, followed by an irreversible retro-Diels-Alder step that releases dinitrogen gas, driving the reaction to completion.[19][20]

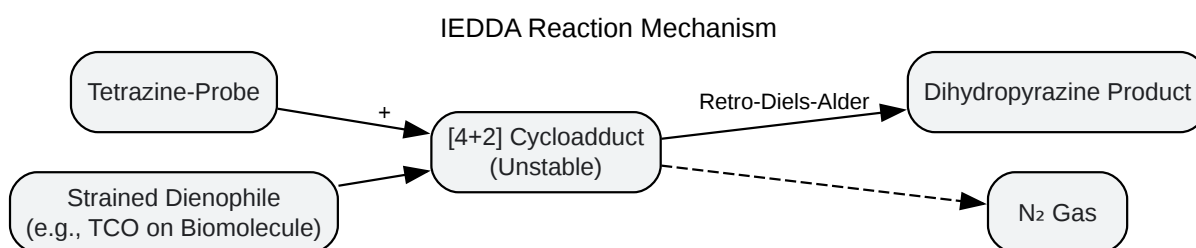

[Click to download full resolution via product page](#)

Caption: Mechanism of the Tetrazine-TCO IEDDA ligation.

Quantitative Data Summary

The choice of bioorthogonal reaction is often dictated by its kinetic properties. The second-order rate constant (k_2) is a critical parameter for comparing different ligation chemistries. The tables below summarize kinetic data for commonly used bioorthogonal reactants.

Table 1: Comparison of Second-Order Rate Constants (k_2) for Bioorthogonal Reactions

Reaction Type	Reactant 1 (on Biomolecule)	Reactant 2 (Probe)	k_2 ($M^{-1}s^{-1}$)	Notes
Staudinger Ligation	Azide	Triarylphosphine	~0.002 - 0.01	Slow kinetics, prone to oxidation.[13]
SPAAC	Azide	Cyclooctyne (OCT)	~0.003	First generation cyclooctyne.[21]
Azide	DIFO	~0.07	Fluorinated, improved kinetics.[4][21]	
Azide	DIBO	~0.1	Dibenzocyclooctyne derivative. [21]	
Azide	DBCO/DIBAC	~0.3 - 1.0	Widely used due to good balance of reactivity and stability.	
Azide	BCN	~0.6 - 1.0	Bicyclononyne, highly stable.[22]	
Azide	BARAC	~0.9	Azacyclooctyne with enhanced reactivity.[22]	
IEDDA	Norbornene	Pyridyl-s-Tetrazine	~1 - 8	Relatively slow for IEDDA but highly specific. [17]
trans-cyclooctene (TCO)	Pyridyl-s-Tetrazine	~300 - 1,000	Very fast reaction rates.[1]	
sTCO (axial TCO)	Monosubstituted Tetrazine	>3,000	Among the fastest bioorthogonal	

			reactions available.[23]
Methylcyclopropene	Pyridyl-s-Tetrazine	~12 - 40	Small, minimally-perturbing dienophile.[19]
Vinylboronic Acid (VBA)	3,6-dipyridyl-s-tetrazine	~2.3	Coordination-assisted reactivity.

Note: Rate constants are approximate and can vary based on solvent, temperature, and the specific molecular context of the reactants.

Applications in Live Cells

Bioorthogonal ligations have unlocked numerous applications for studying and manipulating cellular processes.

Live-Cell Imaging

The most widespread application of bioorthogonal chemistry is in biological imaging.[1] By metabolically incorporating a chemical reporter into a class of biomolecules (e.g., using an azido-sugar to label glycoproteins), researchers can then use a probe conjugated to a fluorophore to visualize their localization and dynamics in living cells with high specificity.[4][24] This approach overcomes the limitations of genetically encoded tags like GFP, as it can be applied to non-protein species like glycans and lipids.[4] Advanced microscopy techniques, such as STED nanoscopy, have been combined with bioorthogonal labeling to achieve super-resolution imaging in live cells.[25][26]

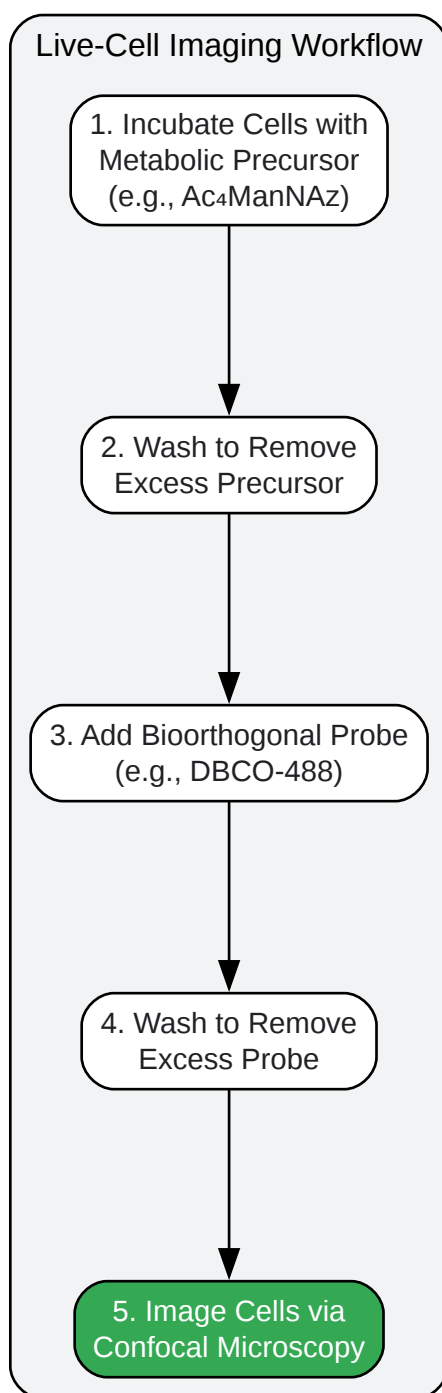

[Click to download full resolution via product page](#)

Caption: A typical experimental workflow for live-cell fluorescence imaging.

Proteomics and Target Identification

Bioorthogonal chemistry is a powerful tool for activity-based protein profiling and identifying the cellular targets of drugs. By attaching a reporter group (e.g., an azide) to a drug candidate or metabolite, researchers can allow it to bind to its target proteins in a live cell. After cell lysis, a probe containing an affinity tag (like biotin) is ligated to the reporter. The tagged proteins can then be enriched using streptavidin beads and identified by mass spectrometry. This technique, known as bioorthogonal non-canonical amino-acid tagging (BONCAT) when applied to newly synthesized proteins, provides a snapshot of the proteome under specific conditions.[27]

Drug Delivery and Therapeutics

Bioorthogonal reactions are being developed for innovative "click-to-release" prodrug strategies and targeted drug delivery systems.[9][28] In one approach, a non-toxic prodrug is activated at a specific site (e.g., a tumor) by an in situ bioorthogonal reaction.[9] Another strategy, known as pre-targeting, involves two steps: first, an antibody modified with a bioorthogonal reactant is administered to target a specific cell type (e.g., cancer cells).[6][20] After the antibody has localized and unbound antibody has cleared from circulation, a second component—a drug or imaging agent carrying the complementary reactant—is administered. This second component then rapidly "clicks" onto the pre-localized antibody, concentrating the therapeutic or diagnostic payload at the desired site and minimizing systemic toxicity.[6][7][8]

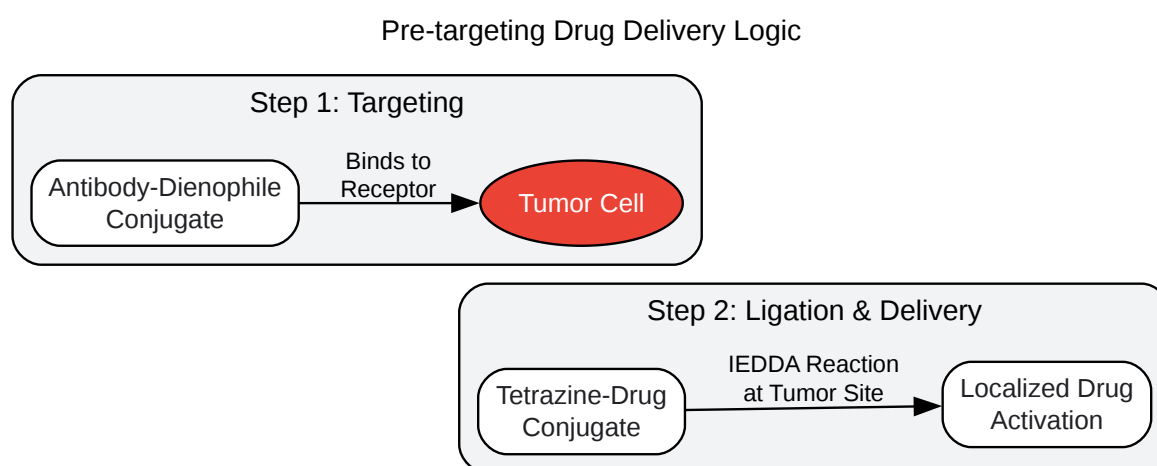

[Click to download full resolution via product page](#)

Need Custom Synthesis?

BenchChem offers custom synthesis for rare earth carbides and specific isotopic labeling.

Email: info@benchchem.com or [Request Quote Online](#).

References

- [1. Bioorthogonal chemistry - Wikipedia \[en.wikipedia.org\]](#)
- [2. Staudinger Ligation Reaction Chemistry | Thermo Fisher Scientific - DE \[thermofisher.com\]](#)
- [3. researchgate.net \[researchgate.net\]](#)
- [4. pnas.org \[pnas.org\]](#)
- [5. Research News: The First Engineering of Cell Surfaces in Living Animals \[www2.lbl.gov\]](#)
- [6. Bioorthogonal, two-component delivery systems based on antibody and drug-loaded nanocarriers for enhanced internalization of nanotherapeutics - PMC \[pmc.ncbi.nlm.nih.gov\]](#)
- [7. Recent advances in developing active targeting and multi-functional drug delivery systems via bioorthogonal chemistry - PubMed \[pubmed.ncbi.nlm.nih.gov\]](#)
- [8. Recent advances in developing active targeting and multi-functional drug delivery systems via bioorthogonal chemistry - ProQuest \[proquest.com\]](#)
- [9. jocpr.com \[jocpr.com\]](#)
- [10. Investigating cellular metabolism of synthetic azidosugars with the Staudinger ligation - PubMed \[pubmed.ncbi.nlm.nih.gov\]](#)
- [11. oipub.com \[oipub.com\]](#)
- [12. pubs.acs.org \[pubs.acs.org\]](#)
- [13. pubs.acs.org \[pubs.acs.org\]](#)
- [14. benchchem.com \[benchchem.com\]](#)
- [15. bioconjugation.bocsci.com \[bioconjugation.bocsci.com\]](#)
- [16. Inverse Electron Demand Diels-Alder Reaction - Creative Biolabs \[creative-biolabs.com\]](#)
- [17. IEDDA: An Attractive Bioorthogonal Reaction for Biomedical Applications - PMC \[pmc.ncbi.nlm.nih.gov\]](#)
- [18. Inverse electron demand Diels–Alder reactions in chemical biology - Chemical Society Reviews \(RSC Publishing\) \[pubs.rsc.org\]](#)

- [19. Application of the Inverse-Electron-Demand Diels-Alder Reaction for Metabolic Glycoengineering - PMC \[pmc.ncbi.nlm.nih.gov\]](#)
- [20. Tetrazine-Based Cycloadditions: Application to Pretargeted Live Cell Imaging - PMC \[pmc.ncbi.nlm.nih.gov\]](#)
- [21. Strain-Promoted Alkyne-Azide Cycloadditions \(SPAAC\) Reveal New Features of Glycoconjugate Biosynthesis - PMC \[pmc.ncbi.nlm.nih.gov\]](#)
- [22. pubs.acs.org \[pubs.acs.org\]](#)
- [23. Systematic Evaluation of Bioorthogonal Reactions in Live Cells with Clickable HaloTag Ligands: Implications for Intracellular Imaging - PMC \[pmc.ncbi.nlm.nih.gov\]](#)
- [24. Bioorthogonal chemical reporters for analyzing protein lipidation and lipid trafficking - PMC \[pmc.ncbi.nlm.nih.gov\]](#)
- [25. Click Chemistry with Cell-Permeable Fluorophores Expands the Choice of Bioorthogonal Markers for Two-Color Live-Cell STED Nanoscopy - PubMed \[pubmed.ncbi.nlm.nih.gov\]](#)
- [26. mdpi.com \[mdpi.com\]](#)
- [27. collaborate.princeton.edu \[collaborate.princeton.edu\]](#)
- [28. Bioorthogonal chemistry based on-demand drug delivery system in cancer therapy \[journal.hep.com.cn\]](#)
- To cite this document: BenchChem. [A Technical Guide to Bioorthogonal Ligation in Live Cells]. BenchChem, [2026]. [Online PDF]. Available at: [\[https://www.benchchem.com/product/b15543264/docs#a-technical-guide-to-bioorthogonal-ligation-in-live-cells\]](https://www.benchchem.com/product/b15543264/docs#a-technical-guide-to-bioorthogonal-ligation-in-live-cells)

Disclaimer & Data Validity:

The information provided in this document is for Research Use Only (RUO) and is strictly not intended for diagnostic or therapeutic procedures. While BenchChem strives to provide accurate protocols, we make no warranties, express or implied, regarding the fitness of this product for every specific experimental setup.

Technical Support: The protocols provided are for reference purposes. Unsure if this reagent suits your experiment?

Need Industrial/Bulk Grade? [Request Custom Synthesis Quote](#)

BenchChem

Our mission is to be the trusted global source of essential and advanced chemicals, empowering scientists and researchers to drive progress in science and industry.

Contact

Address: 3281 E Guasti Rd

Ontario, CA 91761, United States

Phone: (601) 213-4426

Email: info@benchchem.com

[Contact our Ph.D. Support Team for a compatibility check](#)