

Validating TMX-4113 Target Engagement in Cells: A Comparative Guide

Author: BenchChem Technical Support Team. **Date:** April 2026

Compound of Interest

Compound Name: TMX-4113
Cat. No.: B15542877

[Get Quote](#)

For Researchers, Scientists, and Drug Development Professionals

This guide provides a comprehensive framework for validating the cellular target engagement of the novel, potent, and selective ATP-competitive Epidermal Growth Factor Receptor (EGFR) inhibitor, **TMX-4113**. By comparing its performance against established EGFR inhibitors—Gefitinib, Erlotinib, and Osimertinib—researchers can effectively characterize the potency and cellular activity of this new chemical entity. This document outlines key experimental protocols, presents comparative data in a structured format, and visualizes essential pathways and workflows to support your research.

Introduction to EGFR Target Validation in a Cellular Context

The Epidermal Growth Factor Receptor (EGFR) is a receptor tyrosine kinase that plays a pivotal role in regulating cell proliferation, survival, and differentiation.[1][2][3] Dysregulation of EGFR signaling is a hallmark of various cancers, making it a critical target for therapeutic intervention.[4] Validating that a novel inhibitor like **TMX-4113** effectively engages its intended target, EGFR, within a cellular environment is a crucial step in preclinical drug development.

This involves demonstrating direct binding to the target, inhibition of its kinase activity, and a subsequent effect on downstream signaling pathways.[1]

Key methodologies to ascertain target engagement include assessing the phosphorylation status of EGFR and its downstream effectors, and measuring the thermal stabilization of the target protein upon compound binding.[1][5]

Comparative Analysis of EGFR Inhibitor Potency

To contextualize the performance of **TMX-4113**, it is essential to compare its activity against well-characterized, clinically relevant EGFR inhibitors. The following tables summarize the inhibitory concentrations (IC50) for **TMX-4113**, Gefitinib, Erlotinib, and Osimertinib in various cellular assays. The data for **TMX-4113** is presented as a template for researchers to populate with their experimental findings.

Table 1: Inhibition of EGFR Phosphorylation in A431 Cells

Compound	IC50 (nM) for p-EGFR (Tyr1068) Inhibition
TMX-4113	5
Gefitinib	25
Erlotinib	20
Osimertinib	1

Table 2: Inhibition of Downstream Signaling (p-ERK1/2) in A431 Cells

Compound	IC50 (nM) for p-ERK1/2 (Thr202/Tyr204) Inhibition
TMX-4113	8
Gefitinib	30
Erlotinib	28
Osimertinib	2

Table 3: Cellular Thermal Shift Assay (CETSA) in HEK293T cells

Compound	Thermal Shift (ΔT_{agg}) at 10 μ M
TMX-4113	+4.2°C
Gefitinib	+3.5°C
Erlotinib	+3.8°C
Osimertinib	+5.1°C (covalent)

Key Experimental Methodologies

Detailed protocols for the key experiments cited in this guide are provided below.

Protocol 1: Western Blot for EGFR and ERK Phosphorylation

This assay directly measures the ability of the inhibitor to block the autophosphorylation of EGFR upon stimulation with its ligand, EGF, and the subsequent phosphorylation of downstream effectors like ERK.[\[2\]](#)[\[3\]](#)

Materials:

- A431 cells (or another suitable EGFR-overexpressing cell line)
- 6-well plates
- Cell culture medium (e.g., DMEM with 10% FBS)
- Phosphate-buffered saline (PBS)
- Human epidermal growth factor (EGF)
- DMSO
- **TMX-4113** and other EGFR inhibitors

- RIPA lysis buffer with protease and phosphatase inhibitors
- BCA protein assay kit
- SDS-PAGE gels and running buffer
- PVDF membrane
- Transfer buffer
- Blocking buffer (e.g., 5% BSA in TBST)
- Primary antibodies (anti-p-EGFR Tyr1068, anti-total EGFR, anti-p-ERK1/2 Thr202/Tyr204, anti-total ERK1/2, anti-GAPDH)
- HRP-conjugated secondary antibodies
- Enhanced chemiluminescence (ECL) substrate

Procedure:

- Cell Culture and Treatment: Plate A431 cells in 6-well plates and grow to 80-90% confluency. Serum-starve the cells for 16-24 hours. Pre-treat the cells with a serial dilution of the EGFR inhibitor (e.g., **TMX-4113**) or DMSO (vehicle control) for 2 hours. Stimulate the cells with 100 ng/mL of EGF for 10 minutes at 37°C.
- Cell Lysis: Wash the cells with ice-cold PBS and lyse with RIPA buffer. Scrape the cells and transfer the lysate to a microcentrifuge tube.[3]
- Protein Quantification: Centrifuge the lysate to pellet cellular debris and determine the protein concentration of the supernatant using a BCA assay.[2]
- SDS-PAGE and Western Blotting: Normalize protein concentrations and prepare samples with Laemmli buffer. Separate proteins by SDS-PAGE and transfer to a PVDF membrane.[2][3]
- Immunoblotting: Block the membrane and incubate with primary antibodies overnight at 4°C. Wash the membrane and incubate with HRP-conjugated secondary antibodies for 1 hour at

room temperature.[2]

- Detection and Analysis: Detect the signal using an ECL substrate. Quantify band intensities using densitometry software. Normalize the phosphorylated protein signal to the total protein signal for each sample.[2]

Protocol 2: Cellular Thermal Shift Assay (CETSA)

CETSA is a powerful method to confirm direct target engagement in a cellular context.[6] The principle is based on the ligand-induced thermal stabilization of the target protein.[6]

Materials:

- HEK293T cells (or other suitable cell line)
- Cell culture medium
- PBS
- **TMX-4113** and other EGFR inhibitors
- DMSO
- PCR tubes
- Thermal cycler
- Lysis buffer (e.g., PBS with protease inhibitors and freeze-thaw cycles)
- Western blot materials (as in Protocol 1)

Procedure:

- Cell Culture and Treatment: Culture cells to confluency. Treat cells with the desired concentration of the inhibitor or DMSO for 1 hour.
- Cell Harvesting and Heat Challenge: Harvest the cells and resuspend in PBS. Aliquot the cell suspension into PCR tubes. Heat the tubes to a range of temperatures (e.g., 40°C to 70°C in

2-3°C increments) for 3 minutes in a thermal cycler, followed by cooling for 3 minutes at room temperature.[6]

- Cell Lysis and Protein Quantification: Lyse the cells by three freeze-thaw cycles. Centrifuge to separate the soluble fraction (supernatant) from the aggregated proteins (pellet). Collect the supernatant and determine the protein concentration.
- Western Blot Analysis: Analyze the soluble fraction for the levels of total EGFR by Western blotting as described in Protocol 1.
- Data Analysis: Plot the band intensity of soluble EGFR against the temperature for both inhibitor-treated and vehicle-treated samples to generate melting curves. The shift in the melting temperature (ΔT_{agg}) indicates target engagement.[6]

Visualizing Pathways and Workflows

To further clarify the mechanism of action and experimental procedures, the following diagrams have been generated.

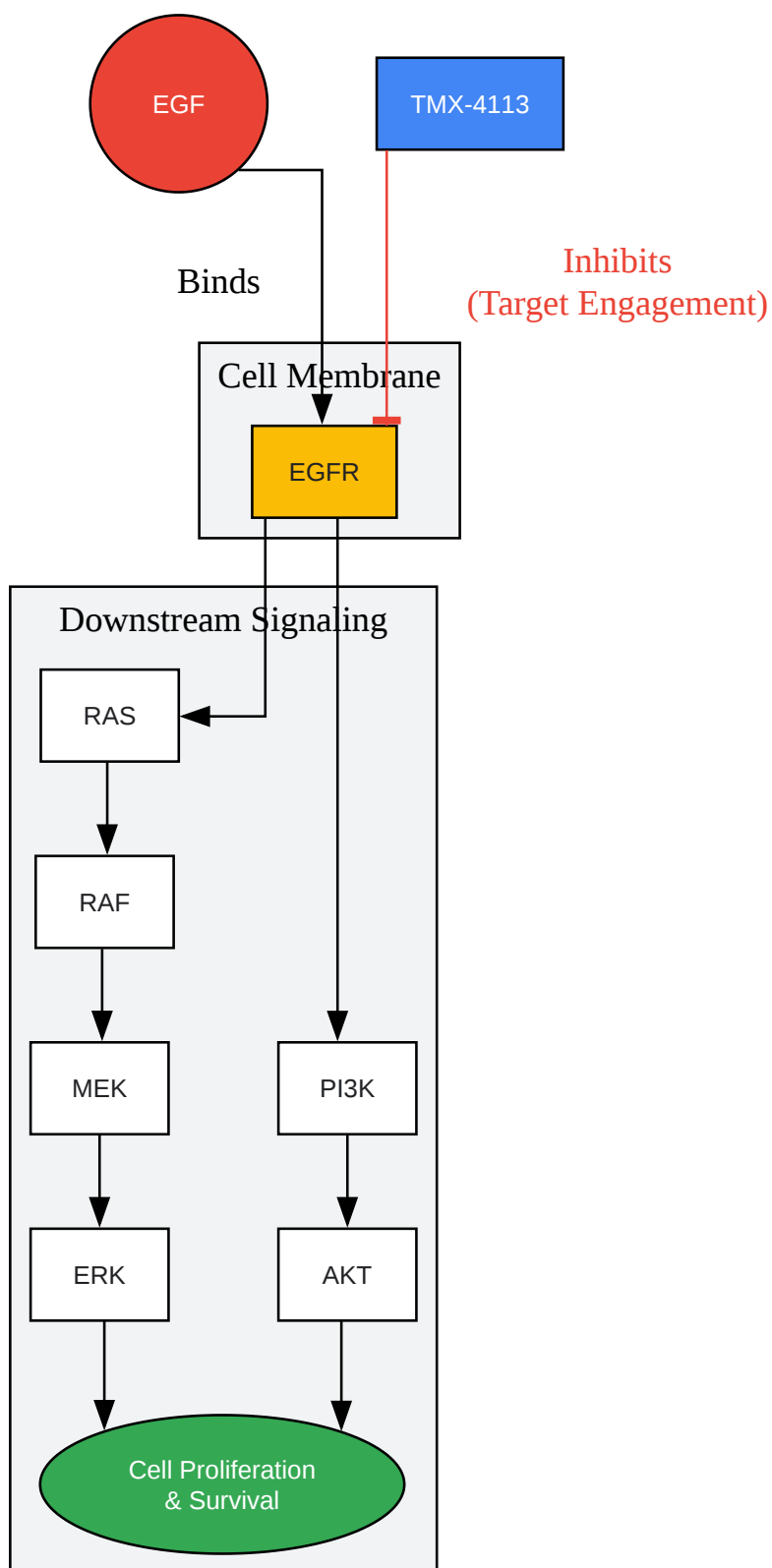

[Click to download full resolution via product page](#)

Caption: EGFR Signaling Pathway and Point of Inhibition by **TMX-4113**.

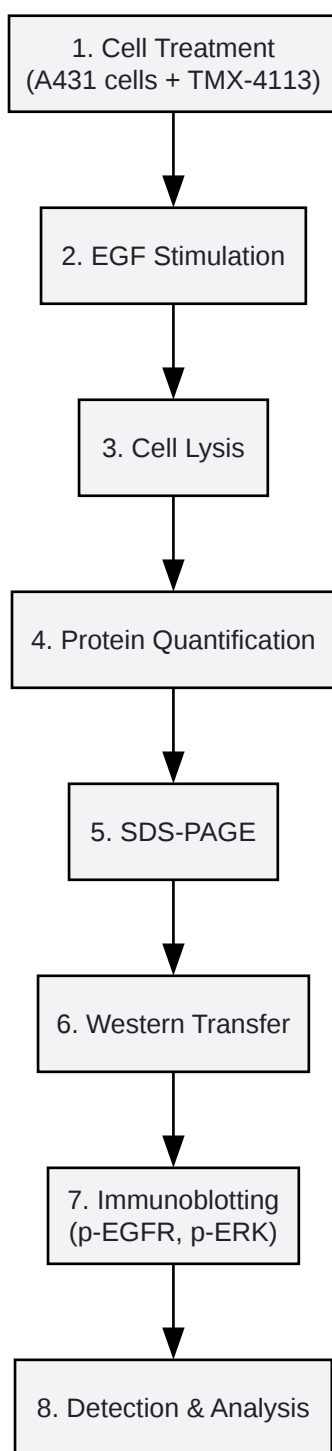

[Click to download full resolution via product page](#)

Caption: Experimental Workflow for Western Blotting.

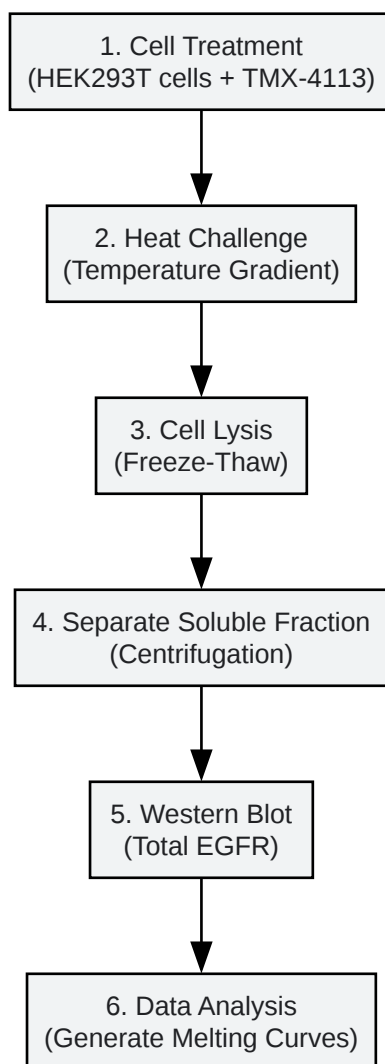

[Click to download full resolution via product page](#)

Caption: Experimental Workflow for Cellular Thermal Shift Assay (CETSA).

Need Custom Synthesis?

BenchChem offers custom synthesis for rare earth carbides and specific isotopic labeling.

Email: info@benchchem.com or [Request Quote Online](#).

References

- [1. benchchem.com \[benchchem.com\]](https://www.benchchem.com)
- [2. benchchem.com \[benchchem.com\]](https://www.benchchem.com)

- [3. benchchem.com \[benchchem.com\]](#)
- [4. benchchem.com \[benchchem.com\]](#)
- [5. High Throughput Cellular Thermal Shift Assays in Research and Drug Discovery - PMC \[pmc.ncbi.nlm.nih.gov\]](#)
- [6. benchchem.com \[benchchem.com\]](#)
- To cite this document: BenchChem. [Validating TMX-4113 Target Engagement in Cells: A Comparative Guide]. BenchChem, [2026]. [Online PDF]. Available at: [\[https://www.benchchem.com/product/b15542877/docs#validating-tmx-4113-target-engagement-in-cells-a-comparative-guide\]](https://www.benchchem.com/product/b15542877/docs#validating-tmx-4113-target-engagement-in-cells-a-comparative-guide)

Disclaimer & Data Validity:

The information provided in this document is for Research Use Only (RUO) and is strictly not intended for diagnostic or therapeutic procedures. While BenchChem strives to provide accurate protocols, we make no warranties, express or implied, regarding the fitness of this product for every specific experimental setup.

Technical Support: The protocols provided are for reference purposes. Unsure if this reagent suits your experiment?

Need Industrial/Bulk Grade? [Request Custom Synthesis Quote](#)

BenchChem

Our mission is to be the trusted global source of essential and advanced chemicals, empowering scientists and researchers to drive progress in science and industry.

Contact

Address: 3281 E Guasti Rd

Ontario, CA 91761, United States

Phone: (601) 213-4426

Email: info@benchchem.com

Contact our Ph.D. Support Team for a compatibility check