

Validating PTPN2 Degradation: A Comparative Guide to Mass Spectrometry and Alternative Methods

Author: BenchChem Technical Support Team. **Date:** April 2026

Compound of Interest

Compound Name: *Protac ptpn2 degrader-1*

Cat. No.: *B15542569*

[Get Quote](#)

For researchers, scientists, and drug development professionals, this guide provides an objective comparison of mass spectrometry-based proteomics with other widely used techniques for validating the degradation of Protein Tyrosine Phosphatase Non-Receptor Type 2 (PTPN2). This guide includes supporting experimental data, detailed methodologies, and visual workflows to aid in the selection of the most appropriate validation strategy.

PTPN2 has emerged as a critical therapeutic target in immuno-oncology and autoimmune diseases. As a negative regulator of inflammatory signaling pathways, its targeted degradation holds immense promise for novel therapeutic interventions. The development of molecules that induce PTPN2 degradation, such as Proteolysis Targeting Chimeras (PROTACs), necessitates robust and accurate methods to validate their efficacy and selectivity. This guide focuses on mass spectrometry as a primary validation tool and compares it with traditional and newer alternative methods.

Data Presentation: Quantitative Comparison of PTPN2 Degradation

The following table summarizes quantitative data from studies validating PTPN2 degradation using different techniques. This allows for a direct comparison of the potency and efficacy of various PTPN2 degraders as measured by different platforms.

Degrader	Method	Cell Line	Key Quantitative Readout	Reference
Compound 1 (Dual PTPN2/N1 Degrader)	Mass Spectrometry (LC-MS/MS)	B16F10	PTPN2 Protein Level Reduction: ~50% at 1 μ M	--INVALID-LINK--
PVD-06 (Selective PTPN2 Degrader)	Western Blot	293T-PTPN2- Flag	DC50: ~10 nM	[1]
PROTAC PTPN2 degrader-1	HiBiT Assay	293T (HiBiT- PTPN2)	DC50: 10-50 nM, Dmax: >90%	

Note: DC50 (half-maximal degradation concentration) is the concentration of a degrader at which 50% of the target protein is degraded. Dmax is the maximum percentage of protein degradation achievable.

Experimental Protocols: Detailed Methodologies

Reproducibility and accuracy are paramount in validating protein degradation. Below are detailed protocols for the key experimental methods discussed in this guide.

Mass Spectrometry-Based Proteomics for PTPN2 Degradation

Mass spectrometry offers a highly sensitive and unbiased approach to globally quantify changes in the proteome, making it the gold standard for assessing both on-target efficacy and off-target effects of a degrader.

1. Sample Preparation:

- **Cell Culture and Treatment:** Plate a suitable cell line (e.g., B16F10 murine melanoma cells) and treat with the PTPN2 degrader at various concentrations and time points. Include a vehicle control (e.g., DMSO).
- **Cell Lysis:** Harvest cells and lyse in a buffer containing protease and phosphatase inhibitors to prevent protein degradation and dephosphorylation. A common lysis buffer is RIPA buffer.
- **Protein Quantification:** Determine the protein concentration of each lysate using a BCA or Bradford assay to ensure equal protein loading for subsequent steps.
- **Protein Digestion:** Reduce and alkylate the protein extracts, followed by enzymatic digestion (typically with trypsin) to generate peptides.
- **Peptide Cleanup:** Desalt the peptide samples using C18 solid-phase extraction (SPE) to remove contaminants that can interfere with mass spectrometry analysis.

2. LC-MS/MS Analysis:

- **Liquid Chromatography (LC):** Separate the peptides using a nano-flow or capillary-flow high-performance liquid chromatography (HPLC) system with a C18 reverse-phase column. A gradient of increasing organic solvent (e.g., acetonitrile) is used to elute the peptides.
- **Mass Spectrometry (MS):** Analyze the eluted peptides using a high-resolution mass spectrometer (e.g., Orbitrap or Q-TOF).
- **Data-Dependent Acquisition (DDA):** The mass spectrometer acquires a full MS scan to measure the mass-to-charge ratio (m/z) of intact peptides, followed by MS/MS scans of the most abundant precursor ions to generate fragmentation spectra for peptide identification.
- **Data-Independent Acquisition (DIA):** The mass spectrometer systematically fragments all peptides within a defined m/z range, providing a comprehensive digital map of the proteome.

3. Data Analysis:

- **Peptide and Protein Identification:** Search the raw mass spectrometry data against a protein database (e.g., UniProt) using a search engine like MaxQuant, Sequest, or Mascot to identify peptides and the proteins they originate from.
- **Protein Quantification:** Quantify the relative abundance of proteins across different samples. For label-free quantification (LFQ), this is typically based on the intensity of the peptide precursor ions.
- **Statistical Analysis:** Perform statistical tests to identify proteins that are significantly up- or down-regulated upon treatment with the PTPN2 degrader.

Western Blot Analysis for PTPN2 Degradation

Western blotting is a widely used, antibody-based technique for the semi-quantitative analysis of protein levels.

1. Sample Preparation and SDS-PAGE:

- Prepare cell lysates as described for mass spectrometry.
- Separate the proteins by size using sodium dodecyl sulfate-polyacrylamide gel electrophoresis (SDS-PAGE).

2. Protein Transfer:

- Transfer the separated proteins from the gel to a membrane (e.g., nitrocellulose or PVDF).

3. Immunodetection:

- **Blocking:** Block the membrane with a protein solution (e.g., bovine serum albumin or non-fat milk) to prevent non-specific antibody binding.
- **Primary Antibody Incubation:** Incubate the membrane with a primary antibody specific for PTPN2.
- **Secondary Antibody Incubation:** Wash the membrane and incubate with a horseradish peroxidase (HRP)-conjugated secondary antibody that recognizes the primary antibody.
- **Detection:** Add a chemiluminescent substrate and detect the signal using an imaging system.

4. Analysis:

- Quantify the band intensities using densitometry software.
- Normalize the PTPN2 band intensity to a loading control protein (e.g., GAPDH or β -actin) to account for variations in protein loading.

HiBiT Assay for PTPN2 Degradation

The HiBiT assay is a sensitive, bioluminescence-based method for quantifying protein abundance in live cells.

1. Cell Line Generation:

- Use CRISPR/Cas9 to insert the 11-amino-acid HiBiT tag into the endogenous PTPN2 gene in the desired cell line. This creates a fusion protein without the need for overexpression.

2. Assay Procedure:

- Plate the HiBiT-PTPN2 cells in a multi-well plate.
- Treat the cells with the PTPN2 degrader.
- Add a detection reagent containing the LgBiT protein and a luciferase substrate. The binding of HiBiT and LgBiT reconstitutes a functional NanoLuc luciferase, generating a luminescent signal.

3. Data Analysis:

- Measure the luminescence using a plate reader. The signal intensity is directly proportional to the amount of HiBiT-PTPN2 protein.
- Calculate the percentage of PTPN2 degradation relative to the vehicle control.

Mandatory Visualizations

To further clarify the concepts and workflows discussed, the following diagrams have been generated using the DOT language.

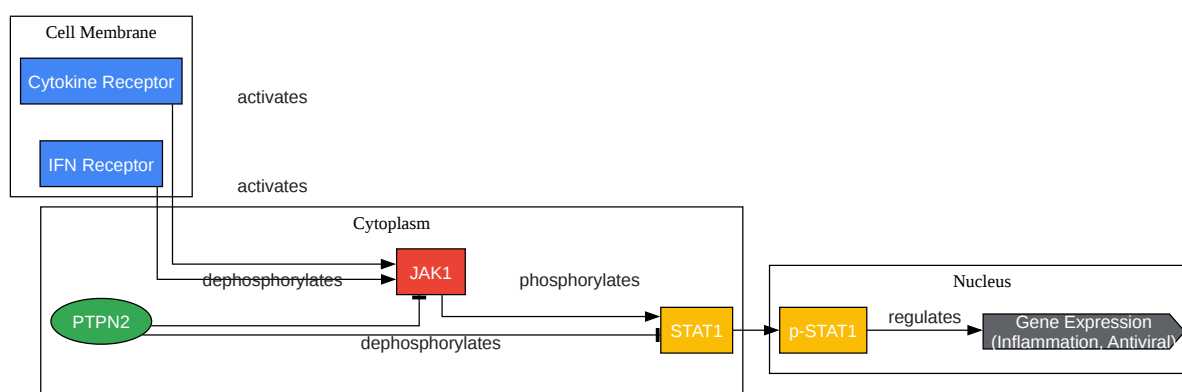

[Click to download full resolution via product page](#)

Caption: PTPN2 negatively regulates the JAK/STAT signaling pathway.

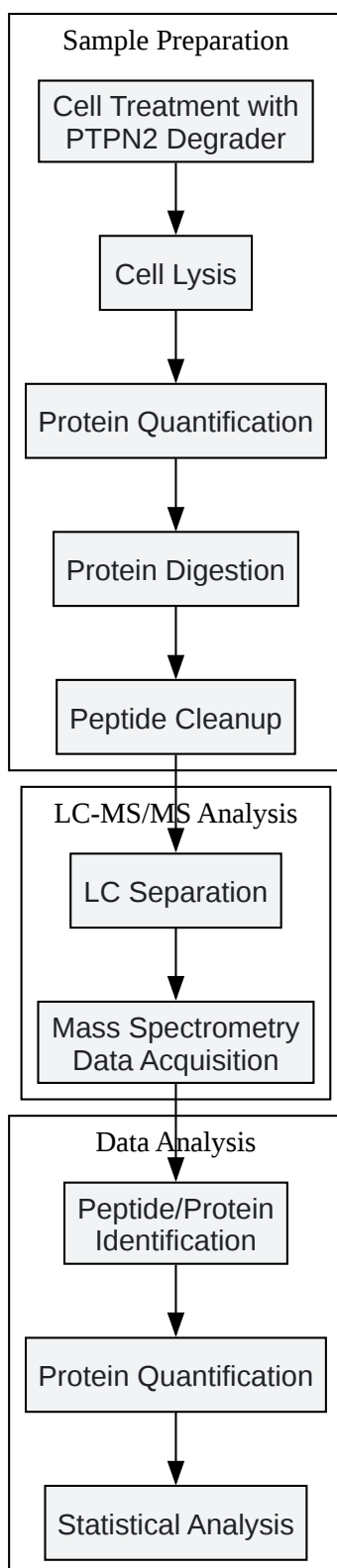

[Click to download full resolution via product page](#)

Caption: Experimental workflow for PTPN2 degradation validation by mass spectrometry.

Caption: Comparison of methods for validating PTPN2 degradation.

Need Custom Synthesis?

BenchChem offers custom synthesis for rare earth carbides and specific isotopic labeling.

Email: info@benchchem.com or [Request Quote Online](#).

References

- [1. Discovery of PVD-06 as a Subtype-Selective and Efficient PTPN2 Degradator - PubMed \[pubmed.ncbi.nlm.nih.gov\]](#)
- To cite this document: BenchChem. [Validating PTPN2 Degradation: A Comparative Guide to Mass Spectrometry and Alternative Methods]. BenchChem, [2026]. [Online PDF]. Available at: [<https://www.benchchem.com/product/b15542569/docs#validating-ptpn2-degradation-a-comparative-guide-to-mass-spectrometry-and-alternative-methods>]

Disclaimer & Data Validity:

The information provided in this document is for Research Use Only (RUO) and is strictly not intended for diagnostic or therapeutic procedures. While BenchChem strives to provide accurate protocols, we make no warranties, express or implied, regarding the fitness of this product for every specific experimental setup.

Technical Support: The protocols provided are for reference purposes. Unsure if this reagent suits your experiment?

Need Industrial/Bulk Grade? [Request Custom Synthesis Quote](#)

BenchChem

Our mission is to be the trusted global source of essential and advanced chemicals, empowering scientists and researchers to drive progress in science and industry.

Contact

Address: 3281 E Guasti Rd

Ontario, CA 91761, United States

Phone: (601) 213-4426

Email: info@benchchem.com

[Contact our Ph.D. Support Team for a compatibility check](#)