

The Role of CSNK2 Inhibition in the DNA Damage Response: A Technical Guide

Author: BenchChem Technical Support Team. **Date:** April 2026

Compound of Interest

Compound Name: *Csnk2-IN-1*

Cat. No.: *B15542652*

[Get Quote](#)

Disclaimer: Extensive searches for the specific inhibitor "**Csnk2-IN-1**" did not yield any publicly available scientific literature, quantitative data, or detailed experimental protocols. Therefore, this guide will focus on the well-characterized role of the target protein, Casein Kinase 2 (CK2), in the DNA Damage Response (DDR). The potent and clinically evaluated CK2 inhibitor, CX-4945 (Silmitasertib), will be used as a representative example to provide specific data and illustrate the mechanistic principles of CK2 inhibition in the context of DNA repair and cancer therapy.

Executive Summary

Casein Kinase 2 (CK2), a highly conserved serine/threonine kinase, is a critical regulator of numerous cellular processes, including cell proliferation, survival, and the DNA Damage Response (DDR).[1][2] Its catalytic subunit, CSNK2A1, is frequently overexpressed in a wide range of human cancers, making it a compelling target for therapeutic intervention.[3][4] Inhibition of CK2 has emerged as a promising strategy to compromise the ability of cancer cells to repair DNA damage, thereby sensitizing them to genotoxic agents and radiation therapy. This technical guide provides an in-depth overview of the role of CK2 in the DDR and the therapeutic potential of its inhibition, using the well-documented inhibitor CX-4945 as a primary example.

The Central Role of CK2 in the DNA Damage Response

CK2 is intricately involved in multiple DNA repair pathways through the phosphorylation of key DDR proteins. Its inhibition can therefore simultaneously disrupt several avenues of DNA damage repair, creating a state of synthetic lethality in cancer cells, particularly in combination with DNA-damaging agents.

CK2's involvement spans across:

- **Single-Strand Break Repair (SSBR):** CK2 phosphorylates the scaffold protein XRCC1, a crucial step for the assembly and activity of the SSBR machinery.^{[5][6]} Inhibition of CK2 prevents this phosphorylation, leading to the accumulation of single-strand breaks.
- **Non-Homologous End Joining (NHEJ):** CK2-mediated phosphorylation of XRCC4 is necessary for the repair of DNA double-strand breaks (DSBs) via the NHEJ pathway.^[1]
- **Homologous Recombination (HR):** CK2 phosphorylates RAD51, a key protein in the HR pathway, which facilitates its recruitment to sites of DNA damage.^[1]
- **DDR Signaling Cascade:** CK2 phosphorylates the mediator of DNA damage checkpoint 1 (MDC1), which is essential for the retention of the MRE11-RAD50-NBS1 (MRN) complex at DSBs, a critical early step in the DDR signaling cascade.^{[1][5]}

The inhibition of these processes by a CK2 inhibitor like CX-4945 leads to an accumulation of unrepaired DNA damage, ultimately triggering cell cycle arrest and apoptosis in cancer cells.

Quantitative Data on CK2 Inhibition by CX-4945

The following table summarizes key quantitative data for the representative CK2 inhibitor, CX-4945 (Silmitasertib).

Parameter	Value	Reference(s)
Target	CSNK2A1 (CK2 α) / CSNK2A2 (CK2 α')	[5]
Mechanism of Action	ATP-competitive inhibitor	[5]
IC50 (in vitro)	1 nM	[5]
Ki	0.38 nM	[5]
Cellular Potency	Dose-dependent inhibition of CK2 substrates (e.g., p-EIF2S2) observed from 4 hours of treatment with 30 μ M in U2OS cells.	
Combination Synergy	Synergistic induction of apoptosis with cisplatin and gemcitabine in ovarian cancer cells.	[6]

Key Experimental Protocols

Detailed methodologies for assessing the impact of CK2 inhibition on the DNA damage response are provided below.

Western Blotting for DDR Protein Phosphorylation

This protocol is used to detect changes in the phosphorylation status of key DDR proteins following treatment with a CK2 inhibitor.

A. Solutions and Reagents:

- Cell Lysis Buffer: 1X SDS Sample Buffer (e.g., from Cell Signaling Technology).
- Wash Buffer: 1X Tris-Buffered Saline with 0.1% Tween® 20 (TBST).
- Blocking Buffer: 5% w/v nonfat dry milk or Bovine Serum Albumin (BSA) in TBST.

- Primary Antibodies: Diluted in blocking buffer as per manufacturer's recommendations. Examples include antibodies against p-XRCC1, p-MDC1, p-CHK2, and total protein controls.
- Secondary Antibody: HRP-conjugated anti-rabbit or anti-mouse IgG, diluted in blocking buffer.
- Detection Reagent: Enhanced Chemiluminescence (ECL) substrate.

B. Protocol:

- Cell Treatment: Plate cells and treat with the CK2 inhibitor (e.g., CX-4945) and/or a DNA-damaging agent for the desired time.
- Lysis: Wash cells with ice-cold PBS and lyse with 1X SDS sample buffer.
- Protein Quantification: Determine protein concentration using a standard assay (e.g., BCA assay).
- SDS-PAGE: Load equal amounts of protein onto a polyacrylamide gel and separate by electrophoresis.
- Transfer: Transfer proteins to a PVDF or nitrocellulose membrane.
- Blocking: Block the membrane with blocking buffer for 1 hour at room temperature.
- Primary Antibody Incubation: Incubate the membrane with the primary antibody overnight at 4°C with gentle agitation.
- Washing: Wash the membrane three times for 5 minutes each with TBST.
- Secondary Antibody Incubation: Incubate the membrane with the HRP-conjugated secondary antibody for 1 hour at room temperature.
- Washing: Repeat the washing step.
- Detection: Incubate the membrane with ECL reagent and visualize the protein bands using a chemiluminescence imaging system.

Immunofluorescence for DNA Damage Foci (γ H2AX)

This method visualizes the formation of nuclear foci of phosphorylated H2AX (γ H2AX), a marker of DNA double-strand breaks.

A. Solutions and Reagents:

- Fixation Solution: 4% Paraformaldehyde (PFA) in PBS.
- Permeabilization Solution: 0.5% Triton™ X-100 in PBS.
- Blocking Solution: 5% BSA in PBS.
- Primary Antibody: Anti- γ H2AX antibody diluted in 1% BSA in PBS.
- Secondary Antibody: Alexa Fluor®-conjugated secondary antibody diluted in 1% BSA in PBS.
- Nuclear Stain: DAPI (4',6-diamidino-2-phenylindole).
- Mounting Medium: Antifade mounting medium.

B. Protocol:

- Cell Culture: Grow cells on glass coverslips and treat with the CK2 inhibitor and/or DNA-damaging agent.
- Fixation: Wash cells with PBS and fix with 4% PFA for 15 minutes at room temperature.
- Permeabilization: Wash with PBS and permeabilize with 0.5% Triton™ X-100 for 10 minutes.
- Blocking: Wash with PBS and block with 5% BSA for 1 hour.
- Primary Antibody Incubation: Incubate with the primary anti- γ H2AX antibody for 1-2 hours at room temperature or overnight at 4°C.
- Washing: Wash three times with PBS.

- Secondary Antibody Incubation: Incubate with the fluorescently labeled secondary antibody for 1 hour in the dark.
- Washing and Staining: Wash three times with PBS, then stain with DAPI for 5 minutes.
- Mounting: Wash with PBS and mount the coverslips onto microscope slides using mounting medium.
- Imaging: Visualize and quantify the γ H2AX foci using a fluorescence microscope.

Clonogenic Survival Assay

This assay assesses the long-term proliferative capacity of cells after treatment, providing a measure of cytotoxicity.

A. Materials:

- Cell culture dishes (6-well or 10 cm).
- Complete growth medium.
- Trypsin-EDTA.
- Fixative: 6% glutaraldehyde.
- Staining solution: 0.5% crystal violet.

B. Protocol:

- Cell Seeding: Plate a known number of cells into culture dishes and allow them to attach overnight.
- Treatment: Treat the cells with the CK2 inhibitor and/or DNA-damaging agent for a specified duration.
- Incubation: Remove the treatment medium, wash with PBS, and add fresh complete medium. Incubate the cells for 1-3 weeks, depending on the cell line, to allow for colony formation (a colony is typically defined as ≥ 50 cells).

- **Fixation and Staining:** Aspirate the medium, wash with PBS, and fix the colonies with glutaraldehyde for 30 minutes. Stain with crystal violet for 30 minutes.
- **Colony Counting:** Wash the dishes with water and allow them to air dry. Count the number of colonies in each dish.
- **Data Analysis:** Calculate the plating efficiency and survival fraction for each treatment condition relative to the untreated control.

Signaling Pathways and Experimental Workflows

The following diagrams, generated using the DOT language for Graphviz, illustrate key signaling pathways and experimental workflows relevant to the study of CK2 inhibition in the DNA damage response.

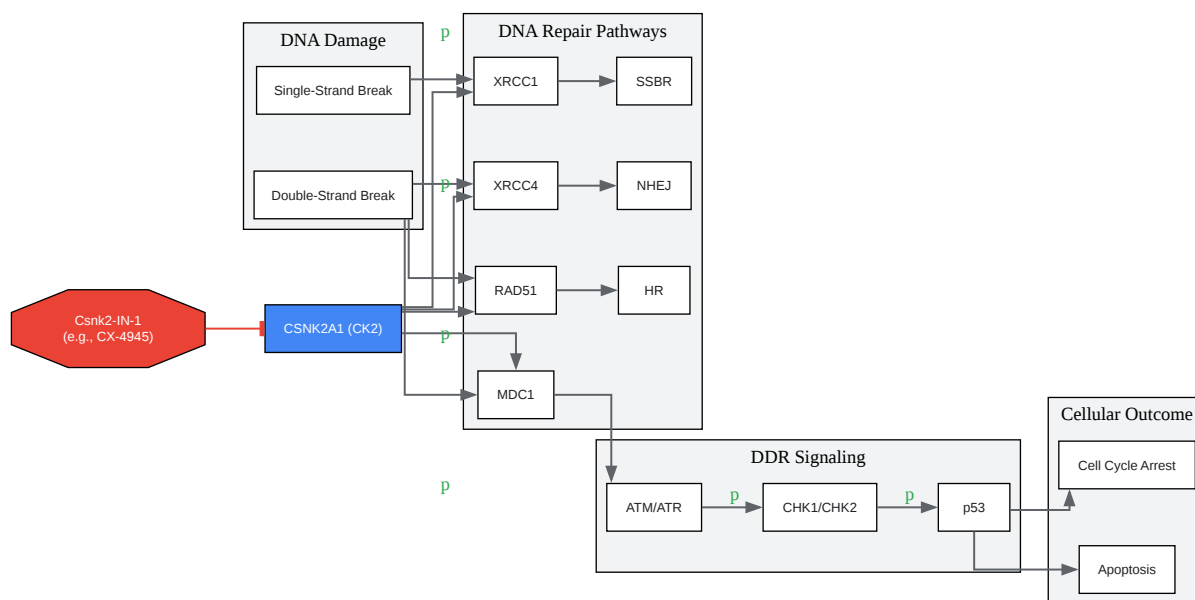

[Click to download full resolution via product page](#)

Caption: CK2's role in DDR and the effect of its inhibition.

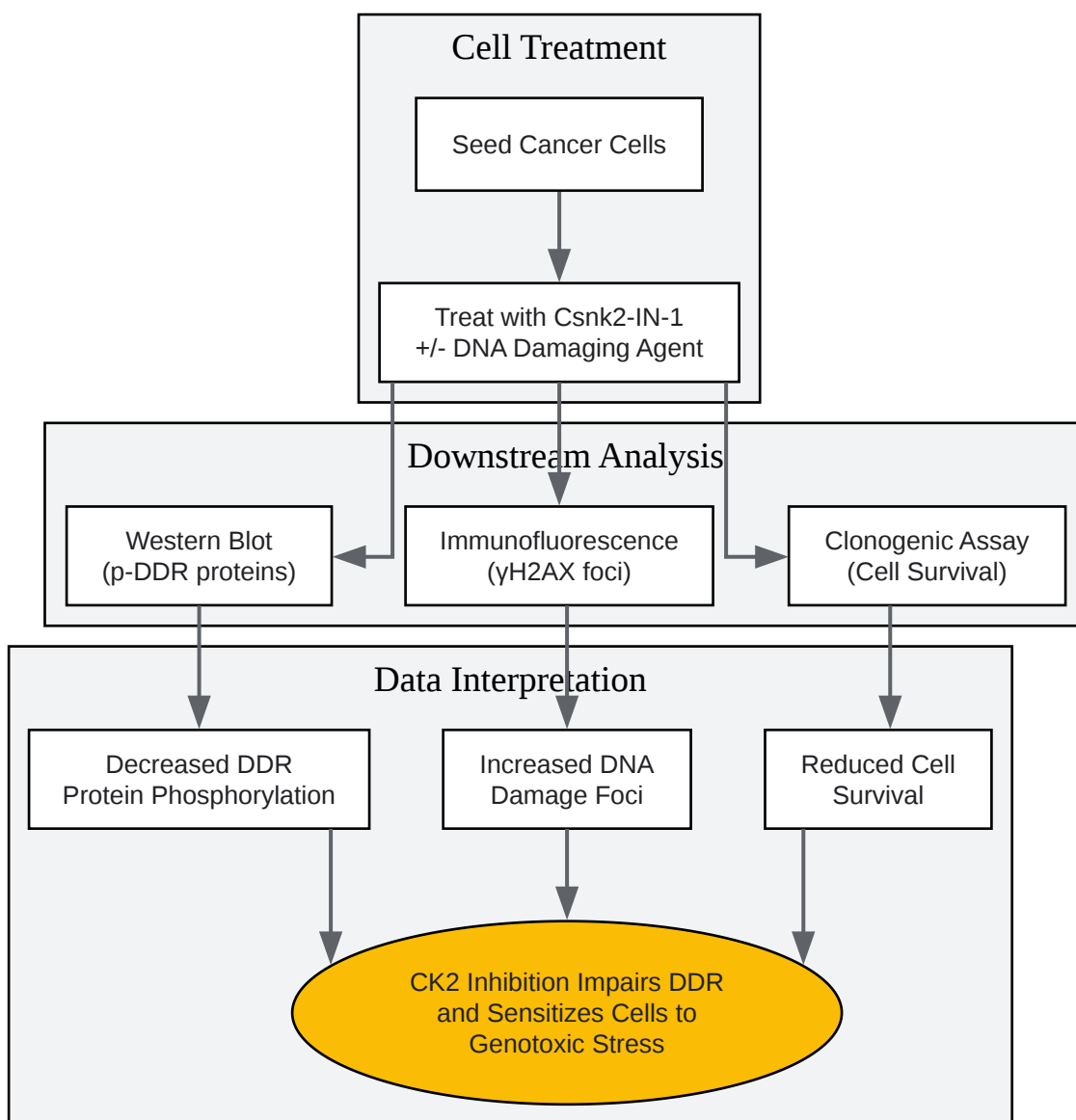

[Click to download full resolution via product page](#)

Caption: Workflow for evaluating **Csk2-IN-1**'s effect on DDR.

Conclusion

The inhibition of Casein Kinase 2 presents a compelling therapeutic strategy for the treatment of cancer. By targeting a key regulator of multiple DNA repair pathways, CK2 inhibitors like CX-4945 can effectively cripple the ability of cancer cells to respond to and repair DNA damage. This not only has the potential for single-agent efficacy in tumors with high replicative stress but also offers a powerful synergistic approach when combined with traditional chemotherapy and

radiotherapy. Further research into novel and more specific CK2 inhibitors is warranted to fully realize the clinical potential of targeting this central node in the DNA damage response network.

Need Custom Synthesis?

BenchChem offers custom synthesis for rare earth carbides and specific isotopic labeling.

Email: info@benchchem.com or [Request Quote Online](#).

References

- [1. ir.lib.uwo.ca](http://ir.lib.uwo.ca) [ir.lib.uwo.ca]
- [2. What are CSNK2A1 inhibitors and how do they work?](http://synapse.patsnap.com) [synapse.patsnap.com]
- [3. CSNK2 in cancer: pathophysiology and translational applications](https://pubmed.ncbi.nlm.nih.gov) - PubMed [pubmed.ncbi.nlm.nih.gov]
- [4. aacrjournals.org](http://aacrjournals.org) [aacrjournals.org]
- [5. aacrjournals.org](http://aacrjournals.org) [aacrjournals.org]
- [6. Frontiers | Chemical Genetic Validation of CSNK2 Substrates Using an Inhibitor-Resistant Mutant in Combination with Triple SILAC Quantitative Phosphoproteomics](https://frontiersin.org) [frontiersin.org]
- To cite this document: BenchChem. [The Role of CSNK2 Inhibition in the DNA Damage Response: A Technical Guide]. BenchChem, [2026]. [Online PDF]. Available at: [<https://www.benchchem.com/product/b15542652/docs#the-role-of-csnk2-inhibition-in-the-dna-damage-response-a-technical-guide>]

Disclaimer & Data Validity:

The information provided in this document is for Research Use Only (RUO) and is strictly not intended for diagnostic or therapeutic procedures. While BenchChem strives to provide accurate protocols, we make no warranties, express or implied, regarding the fitness of this product for every specific experimental setup.

Technical Support: The protocols provided are for reference purposes. Unsure if this reagent suits your experiment?

Need Industrial/Bulk Grade? [Request Custom Synthesis Quote](#)

BenchChem

Our mission is to be the trusted global source of essential and advanced chemicals, empowering scientists and researchers to drive progress in science and industry.

Contact

Address: 3281 E Guasti Rd
Ontario, CA 91761, United States
Phone: (601) 213-4426
Email: info@benchchem.com

[Contact our Ph.D. Support Team for a compatibility check](#)