

# Technical Support Center: Optimizing Linker Length for VH032 Thiol-Based PROTACs

**Author:** BenchChem Technical Support Team. **Date:** April 2026

## Compound of Interest

Compound Name: *VH032 thiol*

Cat. No.: *B15542991*

[Get Quote](#)

Welcome to the technical support center for researchers, scientists, and drug development professionals working on the optimization of linker length for **VH032 thiol**-based Proteolysis Targeting Chimeras (PROTACs). This resource provides troubleshooting guides, frequently asked questions (FAQs), detailed experimental protocols, and data summaries to assist you in your research.

## Frequently Asked Questions (FAQs)

Q1: What is the role of the linker in a **VH032 thiol**-based PROTAC?

A PROTAC is a heterobifunctional molecule composed of a ligand that binds to a target protein, a ligand that recruits an E3 ubiquitin ligase (in this case, a VH032-based ligand for VHL), and a linker connecting the two. The linker's primary function is to position the target protein and the E3 ligase in a conformation that facilitates the transfer of ubiquitin to the target protein, marking it for degradation by the proteasome. The length, composition, and attachment points of the linker are critical parameters that dictate the efficacy of a PROTAC.

Q2: Why is linker length optimization crucial for **VH032 thiol**-based PROTACs?

Optimizing the linker length is essential for the formation of a stable and productive ternary complex (Target Protein-PROTAC-E3 Ligase). If the linker is too short, it can cause steric hindrance, preventing the simultaneous binding of the target protein and the E3 ligase. Conversely, if the linker is too long, it may not effectively bring the two proteins into close enough proximity for efficient ubiquitination, leading to an unstable ternary complex. Therefore, finding the optimal linker length is a critical step in developing a potent PROTAC.

Q3: What are common thiol-reactive groups used in PROTAC linkers?

Common thiol-reactive functional groups that can be incorporated into PROTAC linkers to react with cysteine residues on a target protein include:

- Maleimides: React with thiols via a Michael addition to form a stable thioether bond.
- Haloacetyl groups (e.g., iodoacetyl, bromoacetyl): React with thiols through nucleophilic substitution.
- Acrylamides: Can undergo a Michael addition with thiols. Reversible covalent PROTACs can be designed using cyanoacrylamides.[\[1\]](#)
- Vinyl sulfones: Another group that reacts with thiols via Michael addition.

Q4: What is the "hook effect" in PROTAC experiments and how can linker optimization help?

The "hook effect" is a phenomenon where the degradation of the target protein decreases at high PROTAC concentrations. This occurs because at excessive concentrations, the PROTAC is more likely to form binary complexes with either the target protein or the E3 ligase, rather than the productive ternary complex required for degradation. A well-designed linker can promote positive cooperativity, where the binding of the first protein increases the affinity for the second, making the ternary complex more stable and thus mitigating the hook effect. Modifying linker flexibility, for instance by making it more rigid, can also pre-organize the PROTAC into a conformation more favorable for ternary complex formation.

## Troubleshooting Guide

Problem	Potential Cause	Troubleshooting Steps & Solutions
Low or no degradation of the target protein.	Inefficient Ternary Complex Formation: The linker length or geometry is suboptimal, preventing the productive association of the target protein and VHL.	<ul style="list-style-type: none"> <li>- Synthesize a library of PROTACs with varying linker lengths (e.g., PEG, alkyl chains of different lengths) to identify the optimal distance.</li> <li>- Modify the linker's composition to alter its flexibility and conformational properties.</li> </ul>
Poor Cell Permeability: The PROTAC is not efficiently crossing the cell membrane to reach its intracellular target.	<ul style="list-style-type: none"> <li>- Modify the linker to improve physicochemical properties, such as by incorporating more hydrophilic (e.g., PEG) or rigid elements.</li> <li>- Perform cell permeability assays (e.g., PAMPA) to assess the impact of linker modifications.</li> </ul>	
Inefficient Covalent Reaction: The thiol-reactive warhead is not efficiently forming a covalent bond with the target cysteine residue.	<ul style="list-style-type: none"> <li>- Confirm target engagement using cellular thermal shift assay (CETSA) or LC-MS-based binding assays.</li> <li>- Consider using a more reactive thiol-reactive group or optimizing the reaction conditions (e.g., pH, incubation time).</li> </ul>	
Off-target protein degradation.	Non-specific Binding of the Warhead: The ligand for the target protein has affinity for other proteins.	<ul style="list-style-type: none"> <li>- Use a more selective warhead for your protein of interest.</li> </ul>
Promiscuous Ternary Complex Formation: The linker allows for the recruitment and	<ul style="list-style-type: none"> <li>- Systematically vary the linker length and composition.</li> <li>Sometimes, a subtle change in the linker can alter the</li> </ul>	

ubiquitination of proteins other than the intended target.

geometry of the ternary complex and improve selectivity.

Off-target Reactivity of the Thiol-reactive Group: The thiol-reactive group is reacting with cysteines on other proteins.

- Consider using a reversible covalent warhead to reduce the potential for permanent off-target modifications. - Perform proteomics studies to identify off-target proteins and guide linker redesign to minimize these interactions.

"Hook Effect" observed at high concentrations.

Formation of Unproductive Binary Complexes: At high concentrations, the PROTAC sequesters the target protein and E3 ligase in separate binary complexes.

- Perform a wide dose-response experiment to identify the optimal concentration range for degradation. - Redesign the linker to enhance the cooperativity of ternary complex formation. A more rigid linker might pre-organize the PROTAC in a favorable conformation.

## Quantitative Data on Linker Length and PROTAC Efficacy

The optimal linker length is highly dependent on the specific target protein and the E3 ligase being recruited. Below are examples from the literature illustrating the impact of linker length on the degradation of different target proteins. While not all examples use VH032 with a thiol-based linker, they provide valuable insights into the principles of linker optimization.

Table 1: Effect of Linker Length on BTK Degradation (Covalent PROTACs)

PROTAC	Linker Composition	DC50 (Mino cells)	Dmax (Mino cells)	Reference
IR-1	Acrylamide-based	~10 nM	>90%	[1]
IR-2	Acrylamide-based	~3 nM	>95%	[1]
RC-1	Cyanoacrylamide-based	~30 nM	>90%	[1]
NC-1	Non-covalent	~1 nM	>95%	[1]

Note: This table summarizes data for Bruton's tyrosine kinase (BTK) degraders. While not all are VH032-based, they illustrate the potency of covalent PROTACs.

Table 2: Effect of Linker Length on EGFR Degradation

PROTAC	Target EGFR Mutant	DC50	Dmax	Reference
CP17	EGFRL858R/T790M	1.56 nM	~80%	[2]
CP17	EGFRdel19	0.49 nM	~80%	[2]
PROTAC 3	EGFRdel19	11.7 nM	>90%	[3]
PROTAC 3	EGFRL858R	22.3 nM	>90%	[3]
PROTAC 5	EGFRdel19	5.0 nM	>95%	[3]
PROTAC 5	EGFRL858R	3.3 nM	>95%	[3]

Note: These EGFR degraders utilize different E3 ligase ligands and warheads, but the data highlights the high potency achievable with optimized linkers.

## Experimental Protocols

## Protocol 1: Synthesis of a VH032-PEG-Maleimide PROTAC

This protocol provides a general outline for the synthesis of a VH032-based PROTAC with a PEG linker and a maleimide thiol-reactive group.

### Step 1: Synthesis of VH032-Linker Intermediate

- To a solution of VH032 amine (1 equivalent) in a suitable solvent such as DMF, add a Boc-protected amino-PEG-acid linker (1.1 equivalents).
- Add a coupling agent such as HATU (1.2 equivalents) and a base such as DIPEA (2 equivalents).
- Stir the reaction at room temperature for 2-4 hours, monitoring by LC-MS.
- Upon completion, dilute the reaction with ethyl acetate and wash with saturated sodium bicarbonate solution and brine.
- Dry the organic layer over sodium sulfate, filter, and concentrate under reduced pressure.
- Purify the crude product by flash column chromatography to obtain the Boc-protected VH032-PEG intermediate.
- Deprotect the Boc group using TFA in DCM (1:1) for 1 hour at room temperature.
- Concentrate the reaction mixture under reduced pressure to obtain the VH032-PEG-amine intermediate.

### Step 2: Conjugation of the Maleimide Group

- Dissolve the VH032-PEG-amine intermediate (1 equivalent) in DMF.
- Add maleimidocaproic acid N-hydroxysuccinimide ester (1.1 equivalents) and DIPEA (2 equivalents).
- Stir the reaction at room temperature for 2-4 hours, monitoring by LC-MS.

- Upon completion, purify the reaction mixture directly by preparative HPLC to obtain the final VH032-PEG-maleimide PROTAC.

## Protocol 2: Western Blot for PROTAC-Induced Protein Degradation

This is a standard protocol for quantifying the reduction in target protein levels following PROTAC treatment.<sup>[1][4]</sup>

### 1. Cell Culture and Treatment:

- Plate cells at an appropriate density and allow them to attach overnight.
- Treat cells with a range of PROTAC concentrations (e.g., 0.1 nM to 10  $\mu$ M) and a vehicle control (e.g., DMSO).
- Incubate for a predetermined time (e.g., 6, 12, or 24 hours).

### 2. Cell Lysis:

- Wash cells with ice-cold PBS.
- Lyse cells in RIPA buffer supplemented with protease and phosphatase inhibitors.
- Incubate on ice for 30 minutes.
- Centrifuge to pellet cell debris and collect the supernatant.

### 3. Protein Quantification:

- Determine the protein concentration of each lysate using a BCA or Bradford assay.

### 4. SDS-PAGE and Western Blotting:

- Normalize protein amounts, add Laemmli buffer, and boil the samples.
- Load equal amounts of protein per lane on an SDS-PAGE gel.
- Transfer the separated proteins to a PVDF or nitrocellulose membrane.
- Block the membrane with 5% non-fat milk or BSA in TBST for 1 hour.
- Incubate the membrane with a primary antibody against the target protein overnight at 4°C.
- Wash the membrane with TBST and incubate with an HRP-conjugated secondary antibody for 1 hour at room temperature.
- Wash the membrane again and detect the signal using an ECL substrate and an imaging system.

- Quantify band intensities using densitometry software and normalize to a loading control (e.g., GAPDH,  $\beta$ -actin).

## Visualizations

### Signaling Pathways and Experimental Workflows

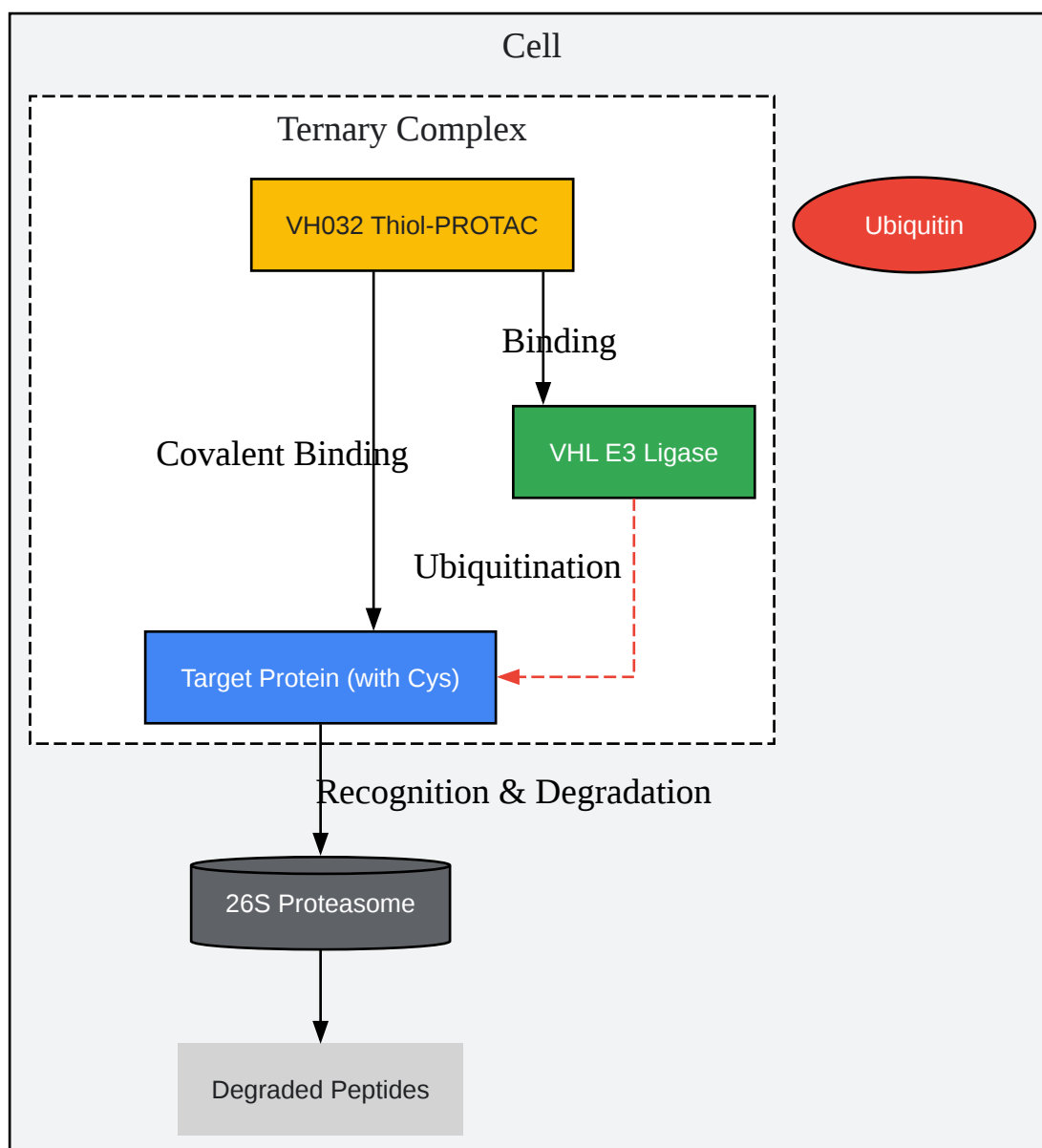

[Click to download full resolution via product page](#)

Caption: Mechanism of action for a **VH032 thiol**-based PROTAC.

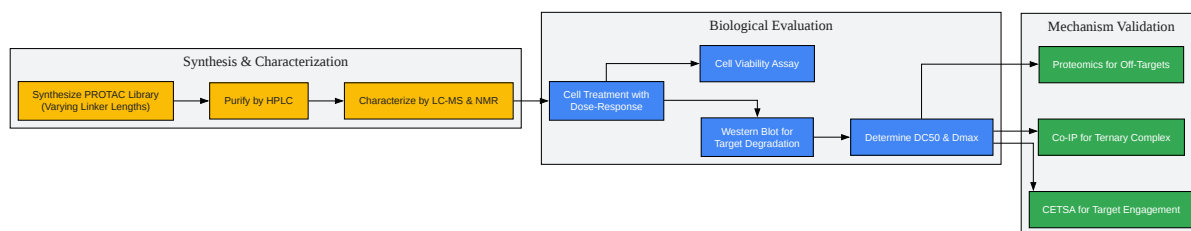

[Click to download full resolution via product page](#)

Caption: Experimental workflow for optimizing **VH032 thiol**-based PROTACs.

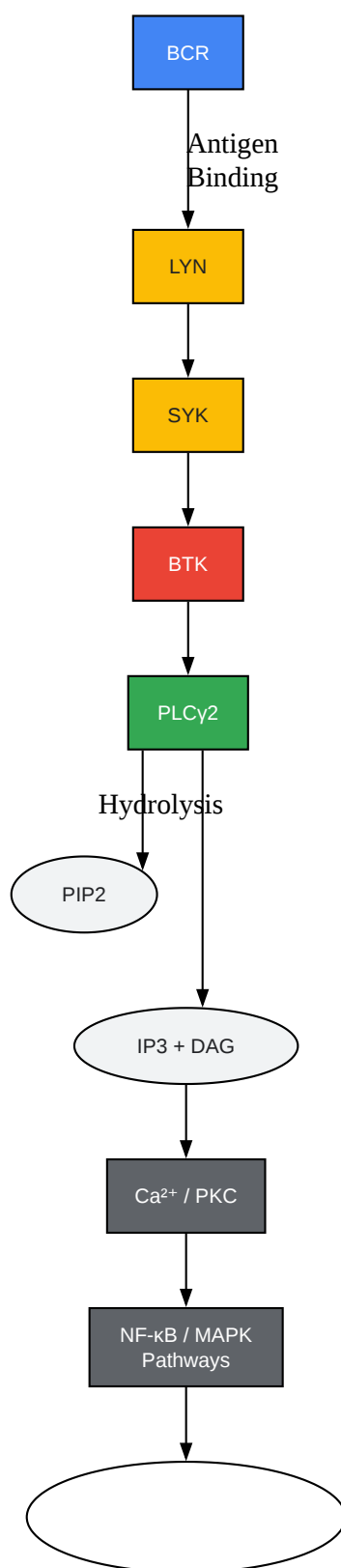

[Click to download full resolution via product page](#)

Caption: Simplified Bruton's Tyrosine Kinase (BTK) signaling pathway.

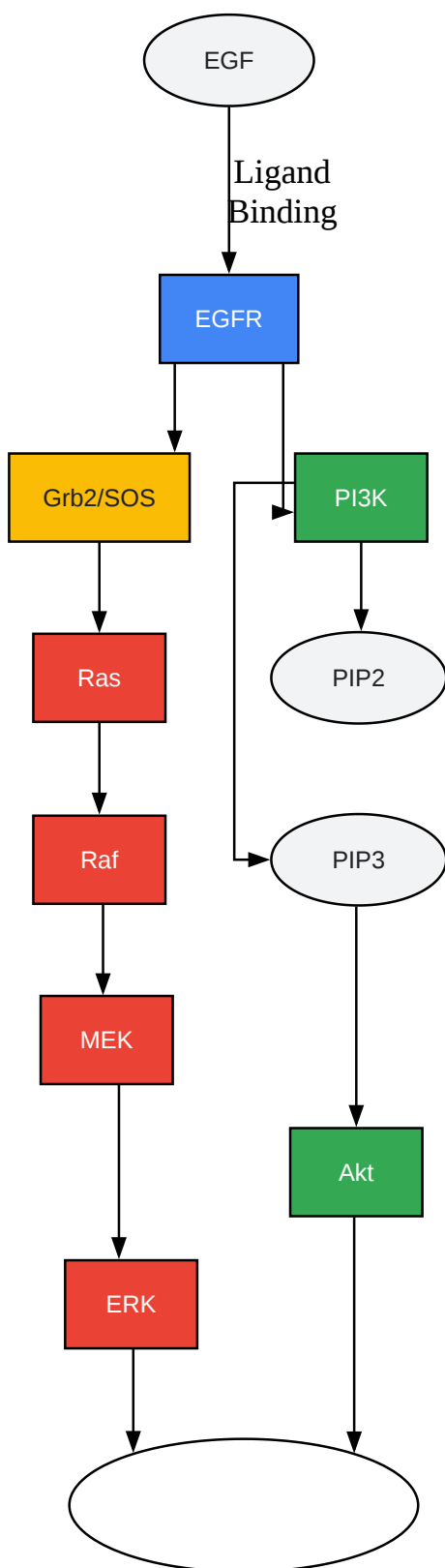

[Click to download full resolution via product page](#)

Caption: Simplified Epidermal Growth factor Receptor (EGFR) signaling pathway.

### Need Custom Synthesis?

BenchChem offers custom synthesis for rare earth carbides and specific isotopic labeling.

Email: [info@benchchem.com](mailto:info@benchchem.com) or [Request Quote Online](#).

## References

- [1. benchchem.com \[benchchem.com\]](#)
- [2. A comprehensive pathway map of epidermal growth factor receptor signaling - PMC \[pmc.ncbi.nlm.nih.gov\]](#)
- [3. benchchem.com \[benchchem.com\]](#)
- [4. benchchem.com \[benchchem.com\]](#)
- To cite this document: BenchChem. [Technical Support Center: Optimizing Linker Length for VH032 Thiol-Based PROTACs]. BenchChem, [2026]. [Online PDF]. Available at: [\[https://www.benchchem.com/product/b15542991/docs#technical-support-center-optimizing-linker-length-for-vh032-thiol-based-protacs\]](https://www.benchchem.com/product/b15542991/docs#technical-support-center-optimizing-linker-length-for-vh032-thiol-based-protacs)

---

### Disclaimer & Data Validity:

The information provided in this document is for Research Use Only (RUO) and is strictly not intended for diagnostic or therapeutic procedures. While BenchChem strives to provide accurate protocols, we make no warranties, express or implied, regarding the fitness of this product for every specific experimental setup.

**Technical Support:** The protocols provided are for reference purposes. Unsure if this reagent suits your experiment?

**Need Industrial/Bulk Grade?** [Request Custom Synthesis Quote](#)

# BenchChem

Our mission is to be the trusted global source of essential and advanced chemicals, empowering scientists and researchers to drive progress in science and industry.

## Contact

Address: 3281 E Guasti Rd

Ontario, CA 91761, United States

Phone: (601) 213-4426

Email: [info@benchchem.com](mailto:info@benchchem.com)

[Contact our Ph.D. Support Team for a compatibility check](#)