

Strategies to reduce non-specific binding of YD23

Author: BenchChem Technical Support Team. **Date:** April 2026

Compound of Interest

Compound Name: PROTAC SMARCA2 degrader-23

Cat. No.: B15542596

[Get Quote](#)

Technical Support Center: YD23

Welcome to the technical support center for YD23. This resource provides researchers, scientists, and drug development professionals with troubleshooting guides and frequently asked questions (FAQs) to address common issues encountered during experiments with YD23, a potent and selective PROTAC (Proteolysis-Targeting Chimera) degrader of the SMARCA2 protein.

Understanding YD23 and its Target

YD23 is a heterobifunctional molecule designed to induce the degradation of SMARCA2 (SWI/SNF-related, matrix-associated, actin-dependent regulator of chromatin, subfamily A, member 2). It achieves this by simultaneously binding to SMARCA2 and an E3 ubiquitin ligase, leading to the ubiquitination and subsequent proteasomal degradation of the SMARCA2 protein. SMARCA2 is a key component of the SWI/SNF chromatin remodeling complex, which plays a crucial role in regulating gene expression.^{[1][2][3][4][5]}

Diagram: The SWI/SNF Chromatin Remodeling Complex

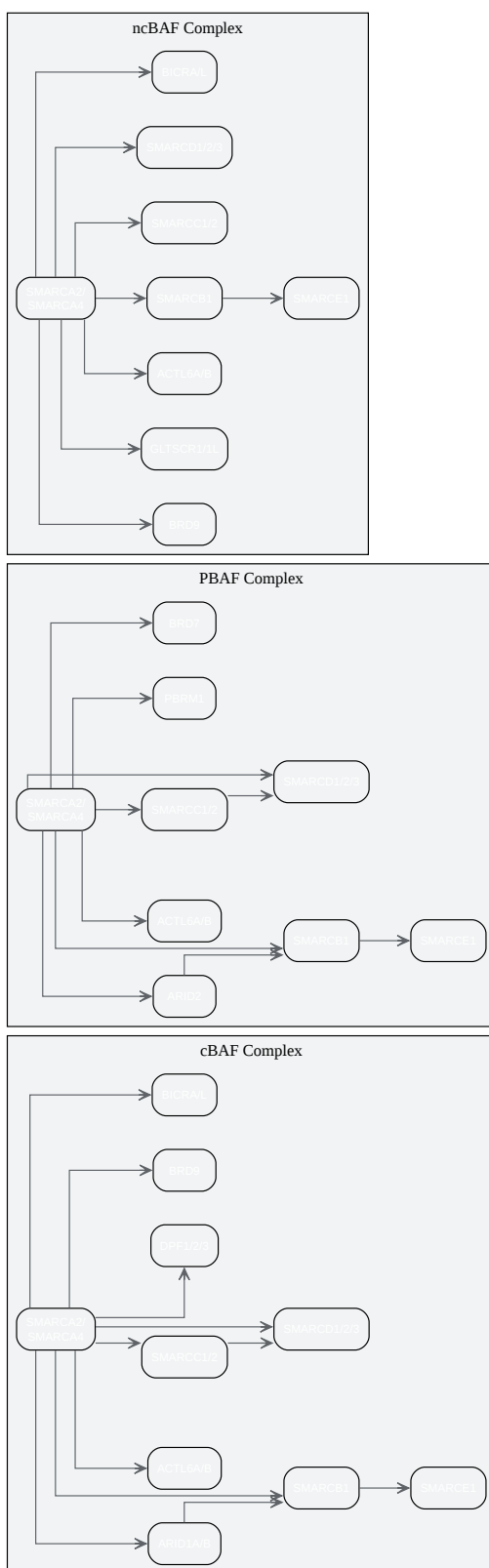

[Click to download full resolution via product page](#)

Caption: The three major mammalian SWI/SNF complexes: cBAF, PBAF, and ncBAF.[1][2][4]

Troubleshooting Guide: Non-Specific Binding of YD23

Non-specific binding (NSB) can be a significant issue in experiments involving PROTACs like YD23, leading to off-target effects and confounding results. This guide provides strategies to minimize NSB in your in vitro assays.

Frequently Asked Questions (FAQs)

Q1: What causes non-specific binding of YD23?

A1: Non-specific binding of small molecules like YD23 is primarily driven by non-covalent interactions such as:

- **Hydrophobic interactions:** The hydrophobic regions of YD23 can interact with hydrophobic surfaces of proteins or plasticware.
- **Ionic interactions:** Charged moieties on YD23 can interact with oppositely charged surfaces.
- **Hydrogen bonding and van der Waals forces:** These weaker interactions can also contribute to non-specific binding.

Q2: How can I detect non-specific binding of YD23 in my assay?

A2: A simple preliminary test is to run your experiment with a control that lacks the primary target (SMARCA2) or by using a structurally similar but inactive control compound. If you still observe a signal or effect, it is likely due to non-specific binding. Techniques like Surface Plasmon Resonance (SPR) can also be used to assess binding to a bare sensor surface as a measure of NSB.^[6]

Q3: What are the initial steps to reduce non-specific binding?

A3: Optimizing your assay buffer is the first and most crucial step. This can involve adjusting the pH, ionic strength, and including blocking agents or detergents.

Strategies to Reduce Non-Specific Binding

The following table summarizes common additives and conditions to mitigate non-specific binding. It is recommended to test a range of concentrations to find the optimal condition for your specific experimental setup.

Strategy	Agent	Typical Concentration Range	Mechanism of Action	Considerations
Protein Blocking	Bovine Serum Albumin (BSA)	0.1% - 1% (w/v) [6][7][8]	Coats surfaces and other proteins, preventing YD23 from binding non-specifically through hydrophobic and ionic interactions. [6][7]	Can sometimes interfere with the primary interaction. Use high-purity, fatty acid-free BSA.
Detergent Addition	Tween-20	0.01% - 0.1% (v/v)[9][10][11] [12][13][14]	A non-ionic detergent that disrupts hydrophobic interactions.[9] [10]	Higher concentrations can disrupt specific binding and protein structure.
Ionic Strength Adjustment	Sodium Chloride (NaCl)	150 mM - 500 mM[15]	Shields electrostatic charges, reducing non-specific ionic interactions.	High salt concentrations can sometimes affect protein stability and specific binding.
pH Optimization	Buffer Selection	pH 6.0 - 8.0	Alters the charge of YD23 and interacting proteins, which can minimize ionic interactions.	Ensure the chosen pH is compatible with the stability and activity of your target protein.

Experimental Protocols

Here are detailed methodologies for key experiments to assess and troubleshoot YD23 binding.

Protocol 1: General Assay Buffer Optimization

This protocol provides a systematic approach to optimizing your assay buffer to reduce non-specific binding.

Workflow Diagram:

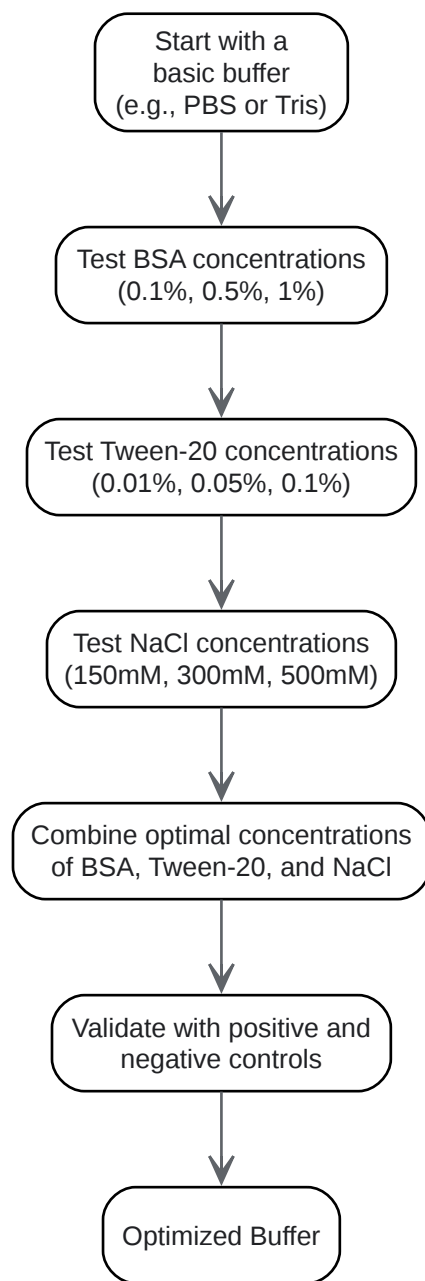

[Click to download full resolution via product page](#)

Caption: A stepwise workflow for optimizing assay buffer conditions.

Methodology:

- Baseline Measurement: Perform your assay with YD23 in a simple buffer (e.g., PBS, pH 7.4) to establish a baseline for non-specific binding. Include a "no target" control.

- **BSA Titration:** Prepare a series of buffers containing increasing concentrations of BSA (e.g., 0.1%, 0.5%, 1.0%). Repeat the assay with each buffer and compare the signal in the "no target" control to the baseline.
- **Tween-20 Titration:** In parallel, prepare buffers with varying concentrations of Tween-20 (e.g., 0.01%, 0.05%, 0.1%). Perform the assay and assess the reduction in non-specific signal.
- **Salt Titration:** Test the effect of ionic strength by adding different concentrations of NaCl (e.g., 150 mM, 300 mM, 500 mM) to your basic buffer.
- **Combination Matrix:** Based on the individual results, design a small matrix of experiments combining the most effective concentrations of BSA, Tween-20, and NaCl to identify the optimal buffer composition.
- **Validation:** Once an optimized buffer is selected, validate it by running your full experiment with appropriate positive and negative controls to ensure that the specific interaction is not compromised.

Protocol 2: Cellular Thermal Shift Assay (CETSA)

CETSA is a powerful method to verify target engagement of YD23 with SMARCA2 in a cellular context.[\[3\]](#)[\[16\]](#)[\[17\]](#)[\[18\]](#)[\[19\]](#)[\[20\]](#)[\[21\]](#)

Workflow Diagram:

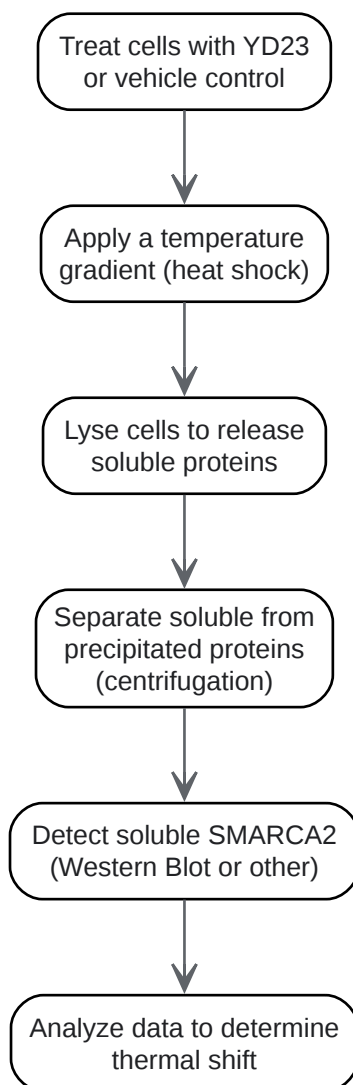

[Click to download full resolution via product page](#)

Caption: Experimental workflow for the Cellular Thermal Shift Assay (CETSA).[3][16][17][18][19][20][21]

Methodology:

- **Cell Treatment:** Culture cells to an appropriate confluency. Treat one set of cells with the desired concentration of YD23 and another set with a vehicle control (e.g., DMSO) for a specified time.
- **Heat Treatment:** Aliquot the cell suspensions into PCR tubes. Heat the tubes at a range of different temperatures for 3 minutes (e.g., 40°C to 70°C in 2°C increments).

- **Cell Lysis:** Immediately after heating, lyse the cells using freeze-thaw cycles or a suitable lysis buffer.
- **Separation of Soluble Fraction:** Centrifuge the lysates at high speed (e.g., 20,000 x g) for 20 minutes at 4°C to pellet the aggregated, denatured proteins.
- **Protein Detection:** Carefully collect the supernatant containing the soluble proteins. Analyze the amount of soluble SMARCA2 at each temperature point by Western Blotting or another quantitative proteomic method.
- **Data Analysis:** Plot the percentage of soluble SMARCA2 as a function of temperature for both the YD23-treated and vehicle-treated samples. A shift in the melting curve to a higher temperature in the presence of YD23 indicates target engagement.

Protocol 3: Isothermal Titration Calorimetry (ITC)

ITC directly measures the heat change upon binding, providing a complete thermodynamic profile of the YD23-SMARCA2 interaction.[\[22\]](#)[\[23\]](#)[\[24\]](#)[\[25\]](#)[\[26\]](#)

Methodology:

- **Sample Preparation:**
 - Prepare a solution of purified SMARCA2 protein (typically 10-50 μM) in a well-defined buffer.
 - Prepare a solution of YD23 (typically 10-20 times the protein concentration) in the exact same buffer. Thoroughly degas both solutions.
- **Instrument Setup:**
 - Clean the ITC cell and syringe thoroughly with the experimental buffer.
 - Load the SMARCA2 solution into the sample cell and the YD23 solution into the injection syringe.
 - Equilibrate the instrument to the desired temperature (e.g., 25°C).

- Titration:
 - Perform a series of small injections (e.g., 2 μ L) of the YD23 solution into the SMARCA2 solution, with sufficient time between injections for the signal to return to baseline.
 - A typical experiment consists of 20-30 injections.
- Control Experiment: Perform a control titration by injecting YD23 into the buffer alone to measure the heat of dilution.
- Data Analysis:
 - Subtract the heat of dilution from the experimental data.
 - Fit the resulting binding isotherm to a suitable binding model (e.g., one-site binding) to determine the binding affinity (K_d), stoichiometry (n), and enthalpy of binding (ΔH).

Protocol 4: Surface Plasmon Resonance (SPR)

SPR is a label-free technique for real-time monitoring of binding kinetics and affinity between YD23 and SMARCA2.^{[6][9][17][18][27]}

Methodology:

- Sensor Chip Preparation:
 - Immobilize purified SMARCA2 protein onto a suitable sensor chip (e.g., CM5 chip via amine coupling).
 - Activate a reference flow cell without immobilizing the protein to serve as a control for non-specific binding and bulk refractive index changes.
- Analyte Preparation: Prepare a series of dilutions of YD23 in an optimized running buffer (determined from Protocol 1).
- Binding Measurement:

- Inject the different concentrations of YD23 over both the SMARCA2-immobilized and reference flow cells at a constant flow rate.
- Monitor the change in the response units (RU) over time to obtain association and dissociation curves.
- Regeneration: After each YD23 injection, regenerate the sensor surface using a suitable regeneration solution (e.g., a low pH buffer) to remove the bound analyte.
- Data Analysis:
 - Subtract the reference flow cell data from the active flow cell data to obtain the specific binding signal.
 - Fit the resulting sensorgrams to a kinetic model (e.g., 1:1 Langmuir binding) to determine the association rate constant (k_a), dissociation rate constant (k_d), and the equilibrium dissociation constant (K_D).

This document is intended for research use only. Please refer to the specific product datasheet for YD23 for detailed storage and handling instructions.

Need Custom Synthesis?

BenchChem offers custom synthesis for rare earth carbides and specific isotopic labeling.

Email: info@benchchem.com or [Request Quote Online](#).

References

- [1. researchgate.net \[researchgate.net\]](#)
- [2. SWI/SNF Family - Creative BioMart \[creativebiomart.net\]](#)
- [3. A Shift in Thinking: Cellular Thermal Shift Assay-Enabled Drug Discovery - PMC \[pmc.ncbi.nlm.nih.gov\]](#)
- [4. mdpi.com \[mdpi.com\]](#)
- [5. medchemexpress.com \[medchemexpress.com\]](#)
- [6. charnwooddiscovery.com \[charnwooddiscovery.com\]](#)

- [7. Adsorption of small molecules to bovine serum albumin studied by the spin-probe method - PubMed \[pubmed.ncbi.nlm.nih.gov\]](#)
- [8. Bovine serum albumin as a universal suppressor of non-specific peptide binding in vials prior to nano-chromatography coupled mass-spectrometry analysis - PubMed \[pubmed.ncbi.nlm.nih.gov\]](#)
- [9. pubs.acs.org \[pubs.acs.org\]](#)
- [10. researchgate.net \[researchgate.net\]](#)
- [11. bosterbio.com \[bosterbio.com\]](#)
- [12. Tween-20 increases the immunoreactivity of apolipoprotein A-I in plasma - PubMed \[pubmed.ncbi.nlm.nih.gov\]](#)
- [13. medchemexpress.com \[medchemexpress.com\]](#)
- [14. researchgate.net \[researchgate.net\]](#)
- [15. Impact of linker length on the activity of PROTACs - Molecular BioSystems \(RSC Publishing\) \[pubs.rsc.org\]](#)
- [16. DARTS vs CETSA: Choosing the Right Assay for Target Validation - Creative Proteomics \[creative-proteomics.com\]](#)
- [17. SPR-Measured Dissociation Kinetics of PROTAC Ternary Complexes Influence Target Degradation Rate - PMC \[pmc.ncbi.nlm.nih.gov\]](#)
- [18. \[PDF\] SPR-Measured Dissociation Kinetics of PROTAC Ternary Complexes Influence Target Degradation Rate | Semantic Scholar \[semanticscholar.org\]](#)
- [19. pelagobio.com \[pelagobio.com\]](#)
- [20. pelagobio.com \[pelagobio.com\]](#)
- [21. youtube.com \[youtube.com\]](#)
- [22. Assays and technologies for developing proteolysis targeting chimera degraders - PMC \[pmc.ncbi.nlm.nih.gov\]](#)
- [23. news-medical.net \[news-medical.net\]](#)
- [24. pure.johnshopkins.edu \[pure.johnshopkins.edu\]](#)
- [25. tainstruments.com \[tainstruments.com\]](#)
- [26. Characterization of protein-protein interactions by isothermal titration calorimetry - PubMed \[pubmed.ncbi.nlm.nih.gov\]](#)
- [27. researchgate.net \[researchgate.net\]](#)

- To cite this document: BenchChem. [Strategies to reduce non-specific binding of YD23]. BenchChem, [2026]. [Online PDF]. Available at: [<https://www.benchchem.com/product/b15542596/docs#strategies-to-reduce-non-specific-binding-of-yd23>]

Disclaimer & Data Validity:

The information provided in this document is for Research Use Only (RUO) and is strictly not intended for diagnostic or therapeutic procedures. While BenchChem strives to provide accurate protocols, we make no warranties, express or implied, regarding the fitness of this product for every specific experimental setup.

Technical Support: The protocols provided are for reference purposes. Unsure if this reagent suits your experiment?

Need Industrial/Bulk Grade? [Request Custom Synthesis Quote](#)

BenchChem

Our mission is to be the trusted global source of essential and advanced chemicals, empowering scientists and researchers to drive progress in science and industry.

Contact

Address: 3281 E Guasti Rd
Ontario, CA 91761, United States
Phone: (601) 213-4426
Email: info@benchchem.com

[Contact our Ph.D. Support Team for a compatibility check](#)