

# Negative Control Experiments for p62-ZZ Ligand 1: A Comparative Guide

**Author:** BenchChem Technical Support Team. **Date:** April 2026

## Compound of Interest

Compound Name: p62-ZZ ligand 1

Cat. No.: B15542964

[Get Quote](#)

For Researchers, Scientists, and Drug Development Professionals

This guide provides a comparative framework for designing and interpreting negative control experiments for a hypothetical small molecule, "**p62-ZZ Ligand 1**," which targets the ZZ domain of the p62/SQSTM1 protein to modulate autophagy. Robust negative controls are critical for validating the specificity of the ligand's action and ensuring that observed effects are directly attributable to its interaction with the p62 ZZ domain.

The p62 protein is a multifunctional scaffold protein that plays a crucial role in various cellular processes, including selective autophagy, inflammation, and signaling pathways like NF- $\kappa$ B and mTORC1.[1][2][3] The ZZ domain of p62 is a zinc finger domain that recognizes and binds to N-terminal arginine (Nt-R) residues on target proteins, a key step in initiating the autophagic clearance of specific cellular components.[1][4][5] Ligands that bind to the p62 ZZ domain can mimic this natural interaction, leading to the self-oligomerization of p62, its interaction with LC3 on autophagic membranes, and ultimately, the induction of autophagosome biogenesis.[6]

## Comparative Analysis of Negative Controls

To validate the on-target activity of **p62-ZZ Ligand 1**, a series of negative control experiments are essential. This guide compares three key types of negative controls: an inactive structural

analog, a non-responsive mutant cell line, and a vehicle control.

Negative Control	Principle	Primary Endpoint	Advantages	Limitations
Inactive Analog	A molecule structurally similar to p62-ZZ Ligand 1 but lacking the ability to bind to the p62 ZZ domain.	Lack of target engagement and downstream signaling.	- Directly assesses the structure-activity relationship.- Controls for off-target effects of the chemical scaffold.	- Availability of a suitable inactive analog.- Potential for the analog to have its own off-target effects.
p62 ZZ-Mutant Cells	Cells expressing a mutant form of p62 (e.g., D129K) where the ZZ domain is incapable of binding to ligands.[5][7]	Absence of ligand-induced p62-dependent autophagy in mutant cells compared to wild-type cells.	- Provides direct genetic evidence of on-target activity.- Highly specific for the intended target.	- Requires generation and validation of stable mutant cell lines.- Potential for compensatory mechanisms in mutant cells.
Vehicle Control	The solvent used to dissolve p62-ZZ Ligand 1 (e.g., DMSO).	No change in basal autophagy levels.	- Simple and essential for all experiments.- Controls for effects of the solvent on cellular processes.	- Does not control for off-target effects of the ligand itself.

## Experimental Protocols

Below are detailed methodologies for key experiments to compare the activity of **p62-ZZ Ligand 1** with the proposed negative controls.

## Co-Immunoprecipitation (Co-IP) for p62-LC3 Interaction

This assay determines if **p62-ZZ Ligand 1** promotes the interaction between p62 and LC3, a key step in autophagy.

Protocol:

- **Cell Culture and Treatment:** Culture wild-type and p62 ZZ-mutant cells to 70-80% confluency. Treat cells with **p62-ZZ Ligand 1**, the inactive analog, or vehicle for the desired time.
- **Cell Lysis:** Wash cells with ice-cold PBS and lyse in NP-40 buffer containing protease inhibitors.
- **Immunoprecipitation:** Incubate cell lysates with anti-p62 antibody overnight at 4°C. Add protein A/G magnetic beads and incubate for an additional 2 hours.
- **Washing:** Collect the beads using a magnetic stand and wash three times with lysis buffer.
- **Elution and Western Blotting:** Elute the bound proteins and analyze by Western blotting using antibodies against p62 and LC3.

## Immunofluorescence for p62 Puncta Formation

This experiment visualizes the ligand-induced aggregation of p62 into puncta, a hallmark of its activation.

Protocol:

- **Cell Culture and Treatment:** Seed cells on glass coverslips and treat with **p62-ZZ Ligand 1**, the inactive analog, or vehicle.
- **Fixation and Permeabilization:** Fix cells with 4% paraformaldehyde and permeabilize with 0.1% Triton X-100.
- **Immunostaining:** Block with 5% BSA and incubate with a primary antibody against p62, followed by a fluorescently labeled secondary antibody.

- Imaging: Mount coverslips and visualize p62 puncta using a fluorescence microscope. Quantify the number and size of puncta per cell.

## Autophagic Flux Assay using tandem mRFP-GFP-LC3

This assay measures the overall efficiency of the autophagy process from autophagosome formation to lysosomal degradation.

Protocol:

- Transfection: Transfect cells with a plasmid encoding the mRFP-GFP-LC3 tandem construct.
- Treatment: Treat the transfected cells with **p62-ZZ Ligand 1**, the inactive analog, or vehicle, in the presence or absence of a lysosomal inhibitor (e.g., bafilomycin A1).
- Imaging and Analysis: Acquire images using a confocal microscope. In autophagosomes (neutral pH), both GFP and mRFP fluoresce (yellow puncta). In autolysosomes (acidic pH), GFP is quenched, and only mRFP fluoresces (red puncta). Autophagic flux is determined by the increase in red puncta upon treatment.

## Expected Quantitative Data Summary

Experiment	p62-ZZ Ligand 1	Inactive Analog	p62 ZZ-Mutant Cells + Ligand 1	Vehicle Control
Co-IP (p62-LC3)	Increased interaction	No change from baseline	No change from baseline	Baseline interaction
p62 Puncta/Cell	Significant increase	No significant change	No significant change	Baseline level
Autophagic Flux	Increased red puncta	No change from baseline	No change from baseline	Baseline flux

## Visualizing the Experimental Logic and Signaling Pathway

To further clarify the experimental design and the underlying biological pathway, the following diagrams are provided.

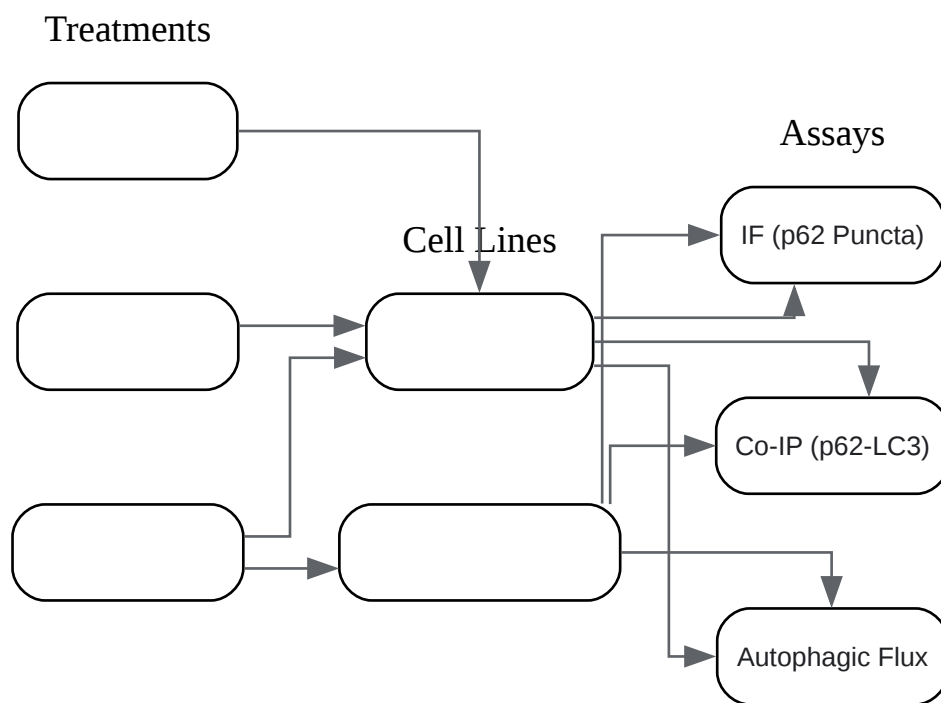

[Click to download full resolution via product page](#)

Caption: Experimental workflow for negative controls.

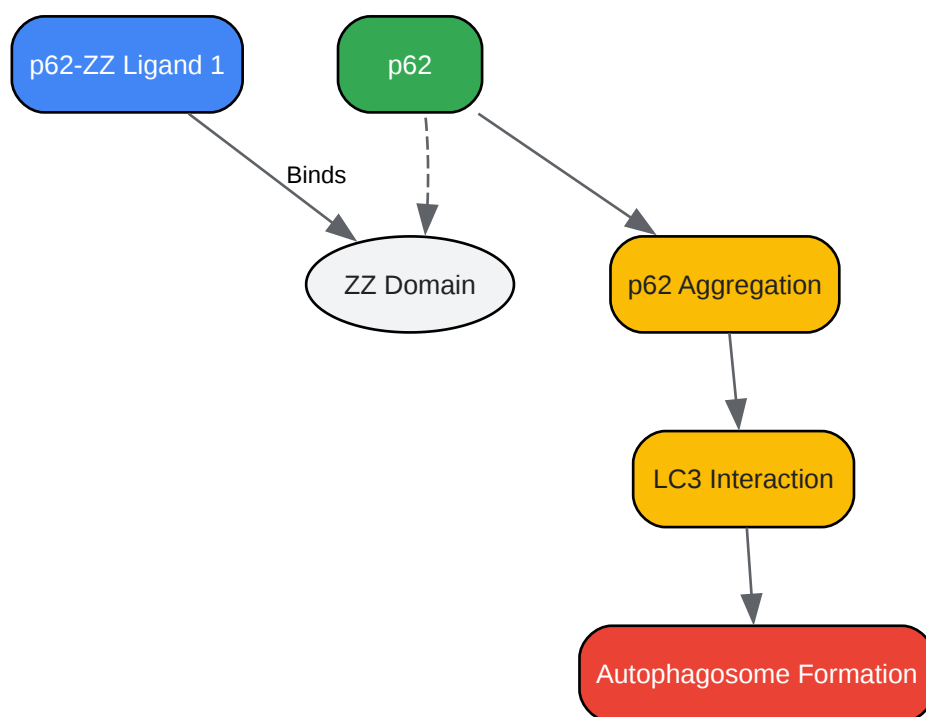

[Click to download full resolution via product page](#)

Caption: **p62-ZZ Ligand 1** signaling pathway.

### Need Custom Synthesis?

BenchChem offers custom synthesis for rare earth carbides and specific isotopic labeling.

Email: [info@benchchem.com](mailto:info@benchchem.com) or [Request Quote Online](#).

## References

- 1. [Frontiers | Selective Autophagy Receptor p62/SQSTM1, a Pivotal Player in Stress and Aging \[frontiersin.org\]](#)
- 2. [The Pathways Underlying the Multiple Roles of p62 in Inflammation and Cancer - PMC \[pmc.ncbi.nlm.nih.gov\]](#)
- 3. [p62/SQSTM1 functions as a signaling hub and an autophagy adaptor - PubMed \[pubmed.ncbi.nlm.nih.gov\]](#)

- [4. ZZ-dependent regulation of p62/SQSTM1 in autophagy - PubMed \[pubmed.ncbi.nlm.nih.gov\]](#)
- [5. researchgate.net \[researchgate.net\]](#)
- [6. p62/SQSTM1/Sequestosome-1 is an N-recognin of the N-end rule pathway which modulates autophagosome biogenesis - PMC \[pmc.ncbi.nlm.nih.gov\]](#)
- [7. Mechanistic insight into the regulation of SQSTM1/p62 - PMC \[pmc.ncbi.nlm.nih.gov\]](#)
- To cite this document: BenchChem. [Negative Control Experiments for p62-ZZ Ligand 1: A Comparative Guide]. BenchChem, [2026]. [Online PDF]. Available at: [\[https://www.benchchem.com/product/b15542964/docs#negative-control-experiments-for-p62-zz-ligand-1-a-comparative-guide\]](https://www.benchchem.com/product/b15542964/docs#negative-control-experiments-for-p62-zz-ligand-1-a-comparative-guide)

---

### Disclaimer & Data Validity:

The information provided in this document is for Research Use Only (RUO) and is strictly not intended for diagnostic or therapeutic procedures. While BenchChem strives to provide accurate protocols, we make no warranties, express or implied, regarding the fitness of this product for every specific experimental setup.

**Technical Support:** The protocols provided are for reference purposes. Unsure if this reagent suits your experiment?

**Need Industrial/Bulk Grade?** [Request Custom Synthesis Quote](#)

## BenchChem

Our mission is to be the trusted global source of essential and advanced chemicals, empowering scientists and researchers to drive progress in science and industry.

### Contact

Address: 3281 E Guasti Rd  
Ontario, CA 91761, United States  
Phone: (601) 213-4426  
Email: [info@benchchem.com](mailto:info@benchchem.com)

Contact our Ph.D. Support Team for a compatibility check