

Control experiments for PROTAC BTK Degradation-12 studies

Author: BenchChem Technical Support Team. **Date:** April 2026

Compound of Interest

Compound Name: PROTAC BTK Degradation-12

Cat. No.: B15542953

[Get Quote](#)

Technical Support Center: PROTAC BTK Degradation-12

Welcome to the technical support center for **PROTAC BTK Degradation-12**. This resource provides troubleshooting guides and answers to frequently asked questions (FAQs) to help researchers and scientists optimize their experiments.

Frequently Asked Questions (FAQs) & Troubleshooting

Q1: My PROTAC BTK Degradation-12 isn't causing any degradation of BTK. What are the common reasons for this and how can I troubleshoot it?

Answer:

Lack of degradation is a common issue when working with new PROTACs. The problem can often be traced to one of several key steps in the PROTAC's mechanism of action. A

systematic troubleshooting approach is recommended to identify the bottleneck.

Troubleshooting Workflow:

The following workflow can help diagnose the reason for a lack of degradation.

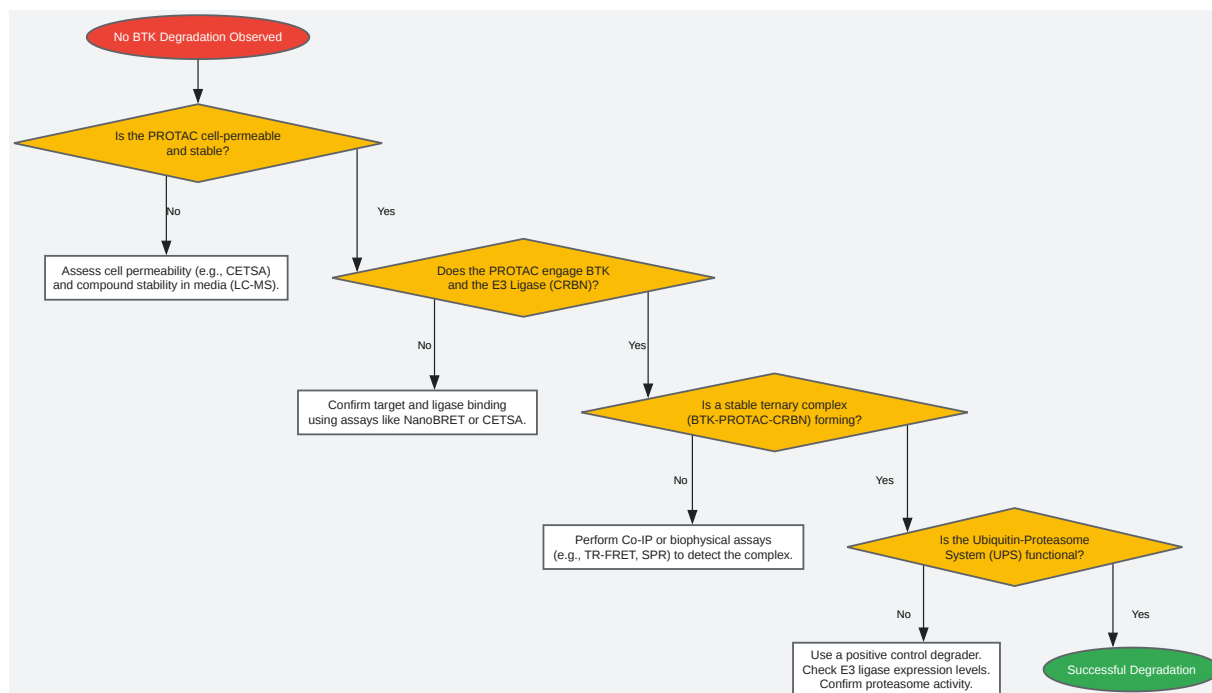

[Click to download full resolution via product page](#)

Caption: Troubleshooting workflow for lack of PROTAC activity.

Key Considerations & Experiments:

- Cell Permeability and Stability: PROTACs are large molecules and may have poor cell permeability.[1] Additionally, the compound could be unstable in your cell culture medium.
 - Solution: Assess intracellular accumulation using methods like the Cellular Thermal Shift Assay (CETSA) or mass spectrometry.[1][2] Check compound stability in media over time via LC-MS/MS.[3]

- Target and E3 Ligase Engagement: The PROTAC must bind to both BTK and the E3 ligase (Cereblon, or CRBN, for this degrader) inside the cell.
 - Solution: Confirm target engagement using cellular assays like NanoBRET™ or CETSA. [1][2]
- Ternary Complex Formation: Successful degradation depends on the formation of a productive ternary complex between BTK, the PROTAC, and the E3 ligase.[4]
 - Solution: Use biophysical assays like TR-FRET, Surface Plasmon Resonance (SPR), or co-immunoprecipitation (Co-IP) to confirm that the PROTAC induces the formation of the ternary complex.[1][4]
- Ubiquitin-Proteasome System (UPS) Function: The degradation machinery itself must be active in your experimental system.
 - Solution:
 - Positive Control: Use a well-characterized PROTAC known to work in your cell line to confirm the UPS pathway is active.
 - E3 Ligase Expression: Verify that the recruited E3 ligase (CRBN) is expressed in your cell line via Western blot.[3]
 - Cell Health: Ensure cells are healthy and within a consistent passage number range, as cellular stress can affect UPS efficiency.[1]

Q2: How do I confirm that BTK degradation is occurring through the intended PROTAC mechanism?

Answer:

To confirm the mechanism of action (MoA), you must demonstrate that the degradation of Bruton's tyrosine kinase (BTK) is dependent on the recruitment of the specific E3 ligase (CRBN) and subsequent processing by the proteasome.[5] This is achieved through a series of essential control experiments.

PROTAC Mechanism of Action (MoA) Workflow:

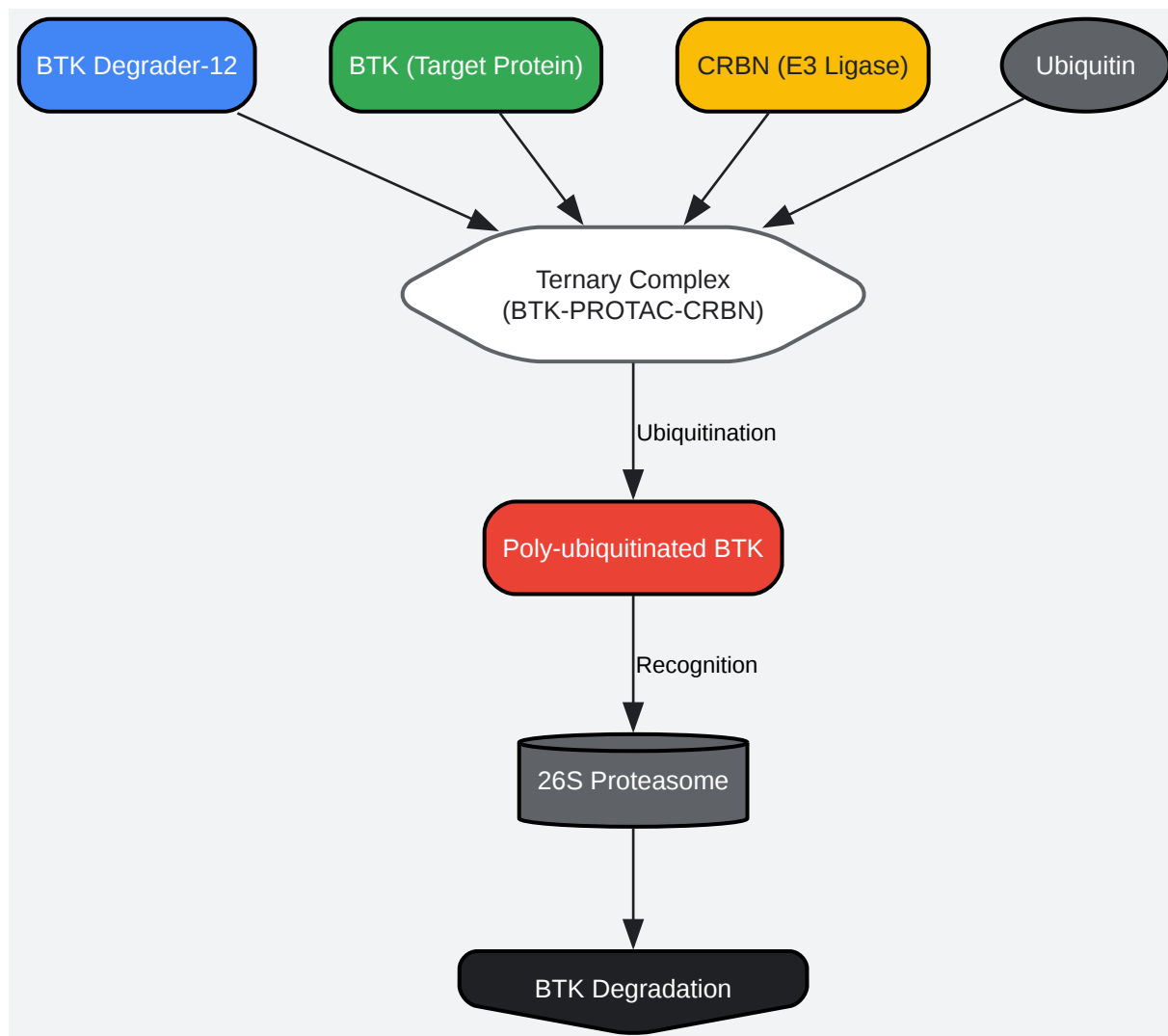

[Click to download full resolution via product page](#)

Caption: PROTAC-mediated protein degradation pathway.

Essential Control Experiments:

Control Experiment	Purpose	Expected Outcome with BTK Degradator-12
Inactive/Negative Control	To prove degradation requires E3 ligase binding. This control is structurally similar but cannot bind CRBN (e.g., via N-methylation of the glutarimide). [6][7]	The inactive control should NOT cause BTK degradation.
Proteasome Inhibitor	To confirm degradation is proteasome-dependent.[8] Pre-treat cells with an inhibitor like MG132 or Bortezomib before adding the PROTAC.	Pre-treatment with a proteasome inhibitor should "rescue" or prevent BTK degradation.
Neddylaton Inhibitor	To confirm dependence on the Cullin-RING E3 ligase (CRL) complex, whose activity requires neddylation. Pre-treat with an inhibitor like MLN4924. [5]	Pre-treatment with MLN4924 should block BTK degradation.
Target Ubiquitination Assay	To directly show that the PROTAC induces the ubiquitination of BTK.[9]	Increased high-molecular-weight smearing (poly-ubiquitinated BTK) upon treatment with the PROTAC and a proteasome inhibitor.

Experimental Protocol: Target Ubiquitination by Immunoprecipitation-Western Blot

This assay confirms that BTK is ubiquitinated in a PROTAC-dependent manner.[1]

- Cell Treatment: Treat cells with:
 - Vehicle (e.g., DMSO)
 - **PROTAC BTK Degradator-12**

- Proteasome inhibitor (e.g., 10 μ M MG132) for 2-4 hours to allow ubiquitinated proteins to accumulate.
- **PROTAC BTK Degradator-12** + MG132.
- Cell Lysis: Lyse cells in a denaturing buffer (e.g., RIPA buffer with 1% SDS) to disrupt protein-protein interactions. Sonicate to shear DNA and reduce viscosity.
- Immunoprecipitation (IP):
 - Dilute the lysate with a non-denaturing buffer to reduce the SDS concentration to ~0.1%.
 - Incubate the lysate with an anti-BTK antibody overnight at 4°C to capture BTK.
 - Add Protein A/G magnetic beads to pull down the antibody-BTK complex.
 - Wash the beads extensively to remove non-specifically bound proteins.
- Western Blotting:
 - Elute the protein from the beads using Laemmli buffer and heat.
 - Separate the proteins by SDS-PAGE and transfer to a PVDF membrane.
 - Probe the membrane with an anti-Ubiquitin antibody to detect ubiquitinated BTK, which will appear as a high-molecular-weight ladder or smear.
 - A separate blot can be run with an anti-BTK antibody to confirm successful immunoprecipitation of BTK.

Q3: I'm observing a cellular phenotype. How can I be sure it's due to BTK degradation and not off-target effects?

Answer:

Distinguishing on-target from off-target effects is critical. A cellular phenotype could be caused by the degradation of an unintended protein or by simple inhibition of BTK (or other kinases) by

the PROTAC's warhead, independent of degradation.[5] A multi-pronged approach is necessary to ensure the observed effects are specific to BTK degradation.

Logical Workflow for Deconvoluting On-Target vs. Off-Target Effects:

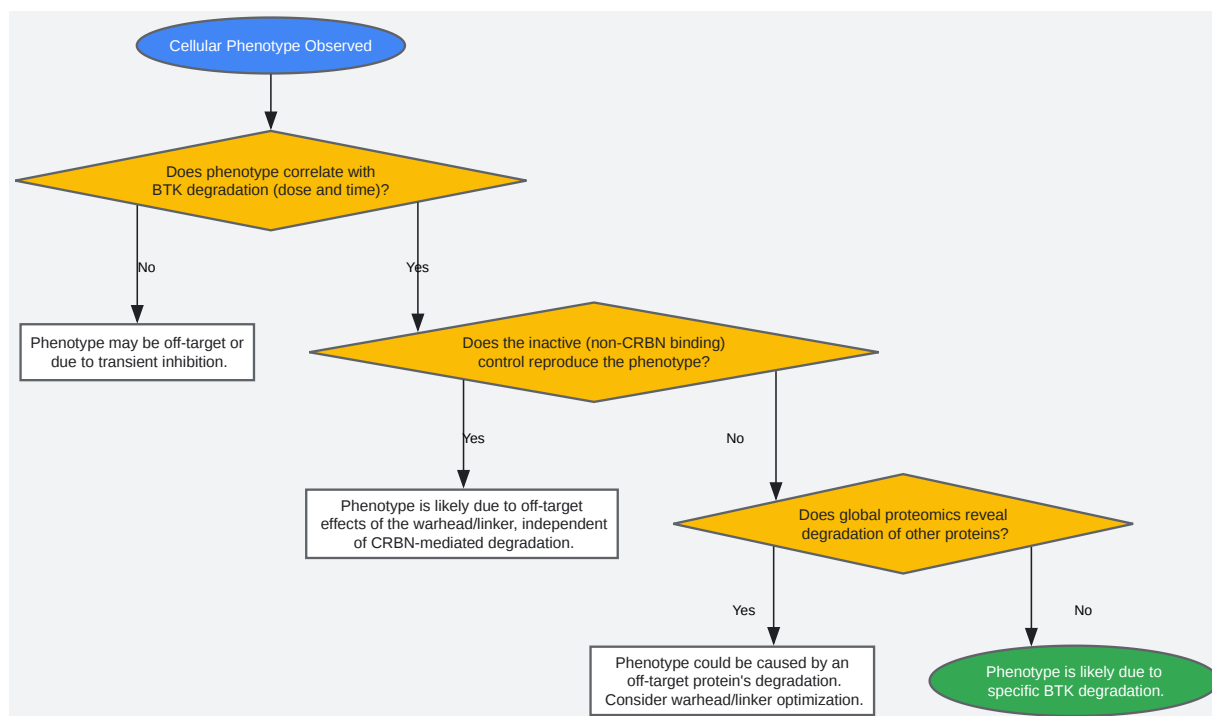

[Click to download full resolution via product page](#)

Caption: Logic for assessing on-target vs. off-target effects.

Key Experiments for Selectivity:

- Use of Controls:
 - Inactive Control: As described in Q2, an inactive control that cannot bind the E3 ligase is the most important tool. If the active PROTAC causes a phenotype but the inactive control does not, it strongly suggests the phenotype is degradation-dependent.[7]
 - Parent Inhibitor (Warhead only): Comparing the effects of the PROTAC to the BTK-binding portion alone can help differentiate between effects caused by simple BTK inhibition

versus those requiring degradation.

- Global Proteomics (Mass Spectrometry): This is the most comprehensive way to assess selectivity.^[10]
 - Methodology: Treat cells for a short duration (e.g., 2-8 hours) with the active PROTAC, the inactive control, and a vehicle.^[5] Analyze the entire proteome using mass spectrometry (e.g., TMT-MS) to identify which proteins are downregulated.
 - Interpretation: A truly selective PROTAC will primarily downregulate BTK. If other proteins are significantly degraded by the active PROTAC but not the inactive control, they are off-target substrates.

Hypothetical Proteomics Data Summary:

Protein	Log2 Fold Change (PROTAC vs. Vehicle)	Log2 Fold Change (Inactive Control vs. Vehicle)	Conclusion
BTK	-3.5	-0.1	On-Target
Protein X	-2.8	-0.2	Off-Target Substrate
Protein Y	-1.5	-1.4	Degradation-Independent Off-Target
Protein Z	+0.2	+0.1	No significant change

Q4: I'm seeing less BTK degradation at higher concentrations of my PROTAC. What is the "hook effect" and how can I avoid it?

Answer:

The "hook effect" is a phenomenon common to PROTACs where increasing the concentration beyond an optimal point leads to a decrease in degradation efficiency.^[1] This results in a characteristic bell-shaped dose-response curve.

It is caused by the formation of non-productive binary complexes at high PROTAC concentrations. Instead of forming a productive ternary complex (BTK-PROTAC-CRBN), the PROTAC independently saturates both BTK and CRBN, preventing them from coming together.

[3]

Conceptual Diagram of the Hook Effect:

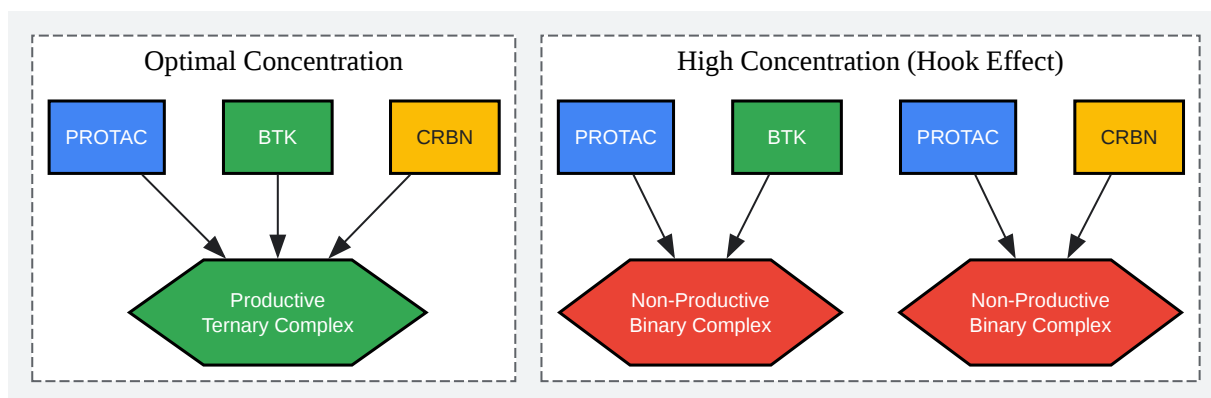

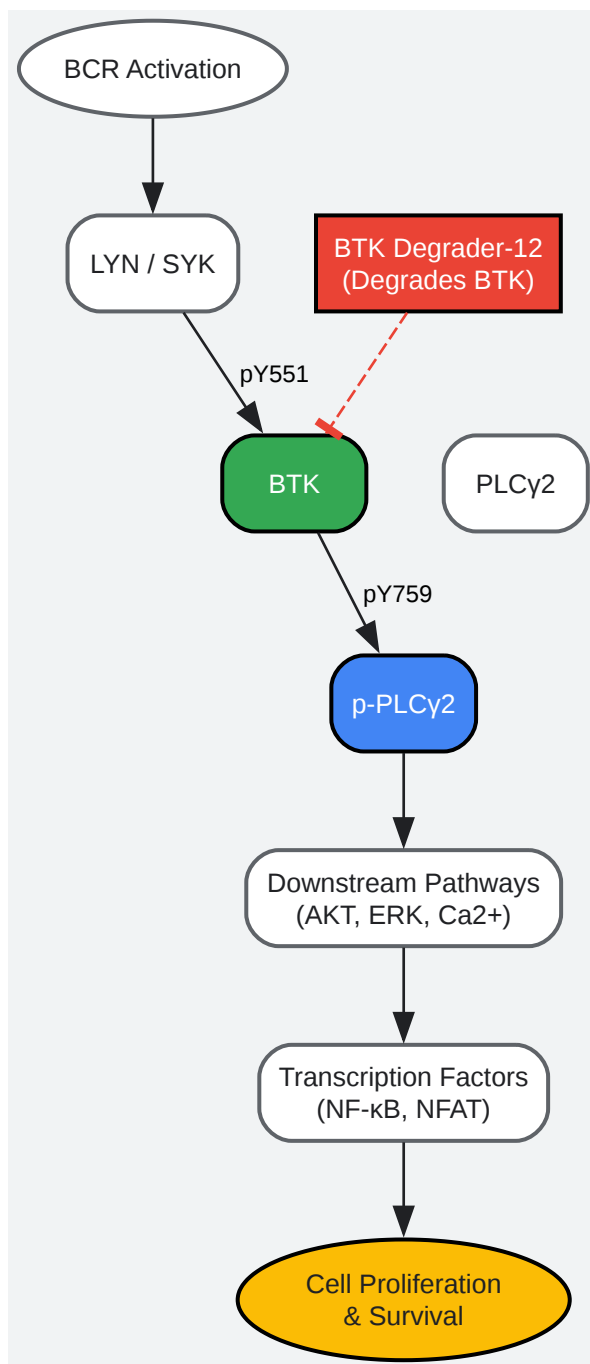

[Click to download full resolution via product page](#)

Need Custom Synthesis?

BenchChem offers custom synthesis for rare earth carbides and specific isotopic labeling.

Email: info@benchchem.com or [Request Quote Online](#).

References

- [1. benchchem.com \[benchchem.com\]](#)
- [2. Quantitative Measurement of PROTAC Intracellular Accumulation - PMC \[pmc.ncbi.nlm.nih.gov\]](#)
- [3. benchchem.com \[benchchem.com\]](#)
- [4. An In Vitro Pull-down Assay of the E3 Ligase:PROTAC:Substrate Ternary Complex to Identify Effective PROTACs | Springer Nature Experiments \[experiments.springernature.com\]](#)
- [5. Targeted Protein Degradation: Design Considerations for PROTAC Development - PMC \[pmc.ncbi.nlm.nih.gov\]](#)
- [6. Orally bioavailable BTK PROTAC active against wild-type and C481 mutant BTKs in human lymphoma CDX mouse models - PMC \[pmc.ncbi.nlm.nih.gov\]](#)
- [7. benchchem.com \[benchchem.com\]](#)
- [8. Proteolysis Targeting Chimeras for BTK Efficiently Inhibit B-Cell Receptor Signaling and Can Overcome Ibrutinib Resistance in CLL Cells - PMC \[pmc.ncbi.nlm.nih.gov\]](#)
- [9. Ubiquitination Assay - Profacgen \[profacgen.com\]](#)
- [10. PROTAC Drug Off-Target Protein Assessment Service | MtoZ Biolabs \[mtoz-biolabs.com\]](#)
- To cite this document: BenchChem. [Control experiments for PROTAC BTK Degradation-12 studies]. BenchChem, [2026]. [Online PDF]. Available at: [\[https://www.benchchem.com/product/b15542953/docs#control-experiments-for-protac-btk-degrader-12-studies\]](https://www.benchchem.com/product/b15542953/docs#control-experiments-for-protac-btk-degrader-12-studies)

Disclaimer & Data Validity:

The information provided in this document is for Research Use Only (RUO) and is strictly not intended for diagnostic or therapeutic procedures. While BenchChem strives to provide accurate protocols, we make no warranties, express or implied, regarding the fitness of this product for every specific experimental setup.

Technical Support: The protocols provided are for reference purposes. Unsure if this reagent suits your experiment?

Need Industrial/Bulk Grade? [Request Custom Synthesis Quote](#)

BenchChem

Our mission is to be the trusted global source of essential and advanced chemicals, empowering scientists and researchers to drive progress in science and industry.

Contact

Address: 3281 E Guasti Rd

Ontario, CA 91761, United States

Phone: (601) 213-4426

Email: info@benchchem.com

[Contact our Ph.D. Support Team for a compatibility check](#)