

Applications of RNA Recruiters in Cancer Research: Application Notes and Protocols

Author: BenchChem Technical Support Team. **Date:** April 2026

Compound of Interest

Compound Name: RNA recruiter 1

Cat. No.: B15542217

[Get Quote](#)

For Researchers, Scientists, and Drug Development Professionals

Introduction

The targeting of RNA with small molecules represents a paradigm shift in precision oncology, moving beyond the traditional protein-centric view of drug discovery. A significant advancement in this field is the development of "RNA recruiters," chimeric molecules designed to bring a specific RNA target into proximity with an effector enzyme, leading to the RNA's degradation. This technology, exemplified by Ribonuclease-Targeting Chimeras (RIBOTACs), offers a novel strategy to silence oncogenic gene expression at the post-transcriptional level.^{[1][2][3]}

These bifunctional molecules typically consist of two key moieties: an RNA-binding domain that selectively recognizes a structured element on a target RNA, and an "RNA recruiter" domain that engages an endogenous ribonuclease, most commonly RNase L.^{[1][2][4]} The induced proximity between the target RNA and RNase L triggers the catalytic degradation of the RNA, thereby preventing the translation of oncoproteins or disrupting the function of oncogenic non-coding RNAs.^{[1][2]} This approach has shown promise in preclinical studies for targeting RNAs previously considered "undruggable."^[1]

This document provides detailed application notes and protocols for the use of RNA recruiters in cancer research, focusing on the RIBOTAC platform.

Mechanism of Action: The RIBOTAC Approach

RIBOTACs function by hijacking the cell's natural RNA decay machinery. The process can be summarized in the following steps:

- **Binding to Target RNA:** The RNA-binding moiety of the RIBOTAC recognizes and binds to a specific structural motif on the target oncogenic RNA (e.g., a hairpin loop in a pre-miRNA or an internal loop in an mRNA).
- **Recruitment of RNase L:** The RNase L recruiting moiety of the RIBOTAC binds to the latent, monomeric form of RNase L, an endoribonuclease involved in the innate immune response.
- **Induced Proximity and RNase L Activation:** The binding of the RIBOTAC to both the target RNA and RNase L brings them into close proximity. This induced proximity facilitates the dimerization and activation of RNase L.
- **Catalytic Degradation of RNA:** The activated RNase L then cleaves the target RNA. Because this process is catalytic, a single RIBOTAC molecule can mediate the destruction of multiple target RNA molecules.^{[2][5]}
- **Downstream Effects:** The degradation of the oncogenic RNA leads to a reduction in the corresponding oncoprotein levels or disrupts oncogenic signaling pathways, ultimately resulting in anti-cancer effects such as apoptosis and inhibition of cell proliferation and invasion.

Mechanism of Action of RNA Recruiters (RIBOTACs)

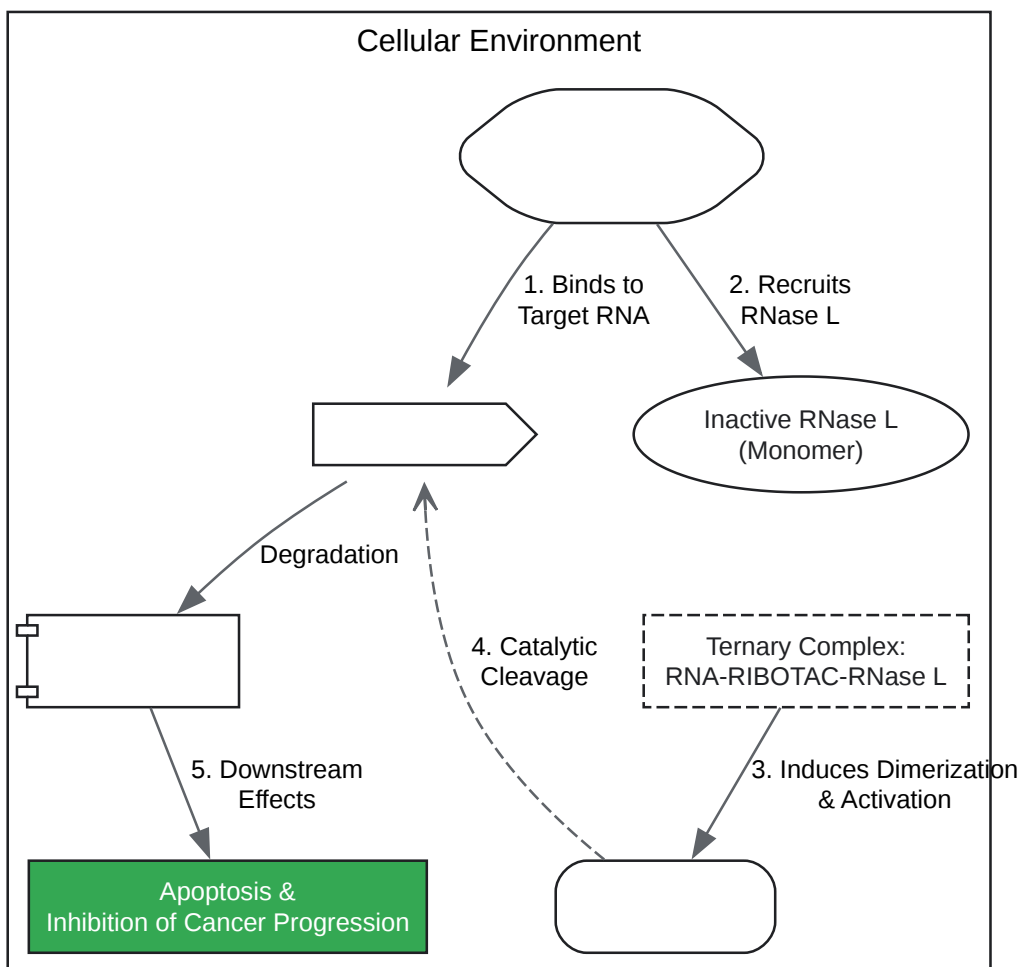

Signaling Pathway Modulation by a pre-miR-96 RNA Recruiter

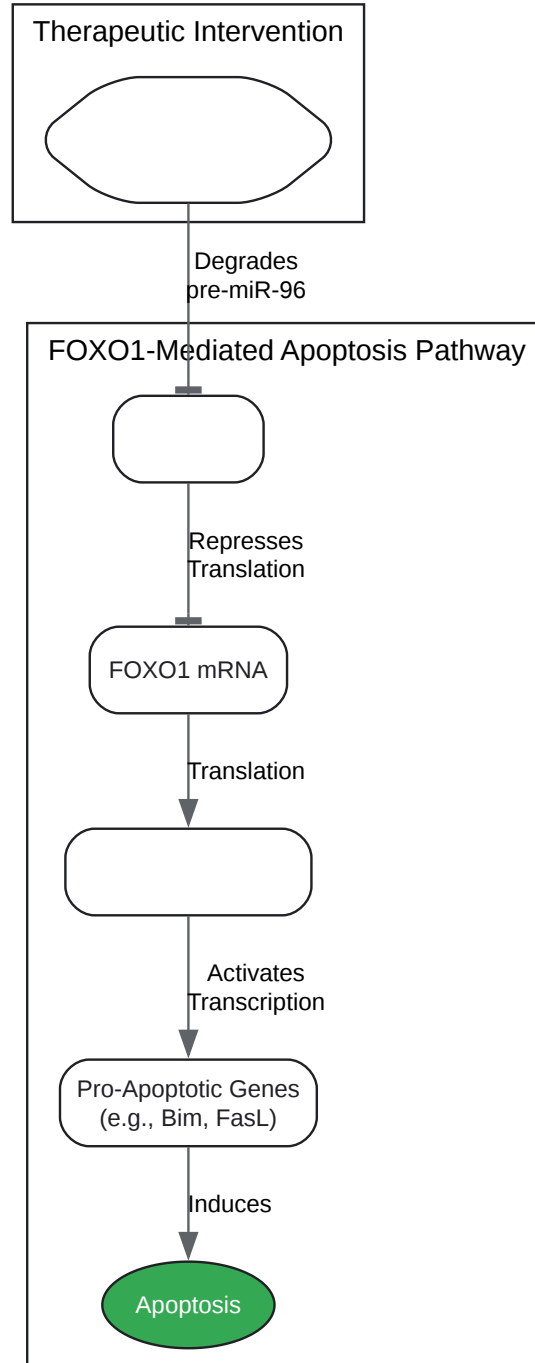

Workflow for In Vitro RNA Degradation Assay

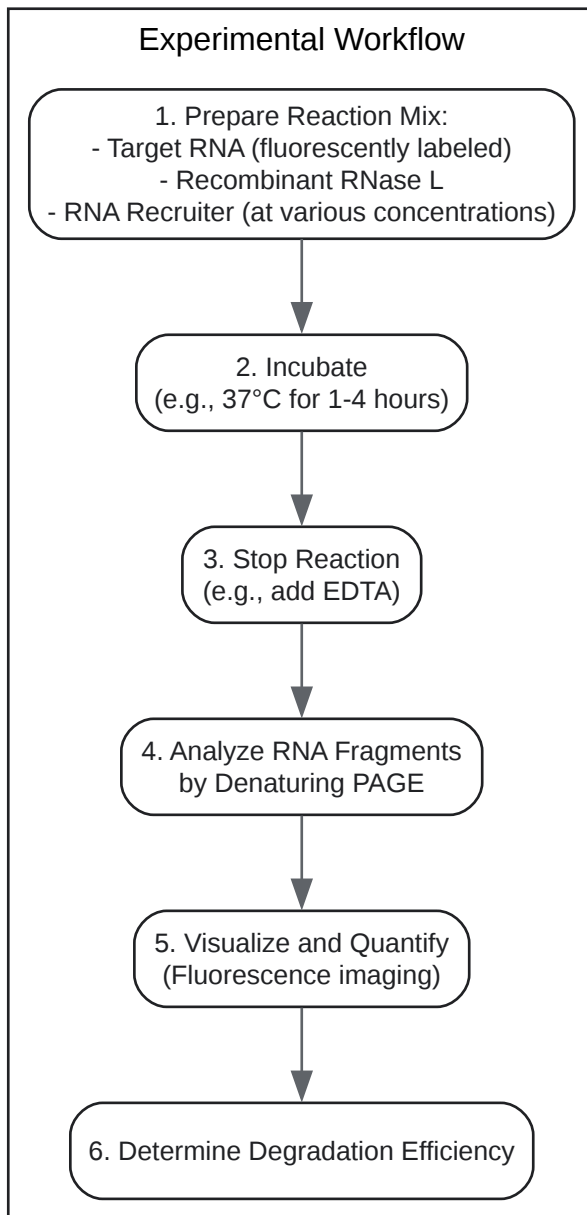

[Click to download full resolution via product page](#)

Need Custom Synthesis?

BenchChem offers custom synthesis for rare earth carbides and specific isotopic labeling.

Email: info@benchchem.com or [Request Quote Online](#).

References

- [1. researchgate.net \[researchgate.net\]](https://www.researchgate.net)
- [2. tandfonline.com \[tandfonline.com\]](https://www.tandfonline.com)
- [3. microRNA Expression Analysis Research | Thermo Fisher Scientific - SG \[thermofisher.com\]](#)
- [4. mcgillradiobiology.ca \[mcgillradiobiology.ca\]](https://www.mcgillradiobiology.ca)
- [5. Clonogenic Assay \[bio-protocol.org\]](https://www.bio-protocol.org)
- To cite this document: BenchChem. [Applications of RNA Recruiters in Cancer Research: Application Notes and Protocols]. BenchChem, [2026]. [Online PDF]. Available at: [\[https://www.benchchem.com/product/b15542217/docs#applications-of-rna-recruiters-in-cancer-research-application-notes-and-protocols\]](https://www.benchchem.com/product/b15542217/docs#applications-of-rna-recruiters-in-cancer-research-application-notes-and-protocols)

Disclaimer & Data Validity:

The information provided in this document is for Research Use Only (RUO) and is strictly not intended for diagnostic or therapeutic procedures. While BenchChem strives to provide accurate protocols, we make no warranties, express or implied, regarding the fitness of this product for every specific experimental setup.

Technical Support: The protocols provided are for reference purposes. Unsure if this reagent suits your experiment?

Need Industrial/Bulk Grade? [Request Custom Synthesis Quote](#)

BenchChem

Our mission is to be the trusted global source of essential and advanced chemicals, empowering scientists and researchers to drive progress in science and industry.

Contact

Address: 3281 E Guasti Rd
Ontario, CA 91761, United States
Phone: (601) 213-4426
Email: info@benchchem.com

[Contact our Ph.D. Support Team for a compatibility check](#)