

A Comparative Guide to DUPA and PSMA-11 for Prostate Cancer Imaging

Author: BenchChem Technical Support Team. **Date:** April 2026

Compound of Interest

Compound Name: DUPA
Cat. No.: B15542648

[Get Quote](#)

Prostate-Specific Membrane Antigen (PSMA) has emerged as a crucial biomarker for prostate cancer due to its significant overexpression on the surface of prostate cancer cells, with levels 100 to 1000 times higher than in other tissues.[1][2] This characteristic makes it an exceptional target for molecular imaging and targeted therapy. Among the numerous ligands developed to target PSMA, **DUPA** and PSMA-11 are two prominent urea-based small molecules that have been extensively studied.

This guide provides an objective comparison of **DUPA**- and PSMA-11-based imaging agents, focusing on their performance, underlying experimental data, and methodologies for their use in prostate cancer imaging. The information is intended for researchers, scientists, and professionals in drug development seeking to understand the nuances of these two important classes of PSMA-targeting agents.

Structural and Functional Overview

Both **DUPA** and PSMA-11 are built upon a glutamate-urea-ligand pharmacophore that binds with high affinity to the enzymatic active site of PSMA. However, their specific chemical structures, and consequently the chelators and radionuclides they are typically paired with, differ.

- **DUPA** (2-[3-(1,3-dicarboxypropyl)ureido]pentanedioic acid) is a symmetrical urea-based molecule derived from two L-glutamic acid units.[1] Its structure provides a versatile scaffold where one of the carboxylic acid groups can be used to conjugate imaging reporters (like radionuclides) or therapeutic agents.[1] **DUPA** has been foundational in the development of various PSMA-targeted agents, including imaging probes and drug conjugates.[3][4][5]
- PSMA-11 (Glu-urea-Lys(Ahx)-HBED-CC) is a highly specific ligand that incorporates the glutamate-urea core for PSMA binding. It is linked to the high-affinity Gallium-68 (^{68}Ga) chelator, HBED-CC.[6] The resulting radiopharmaceutical, [^{68}Ga]Ga-PSMA-11, has become a gold standard in PET imaging for prostate cancer and was the first ^{68}Ga -radiopharmaceutical to receive FDA approval for this indication.[7]

General Structure of PSMA-Targeting Imaging Agents

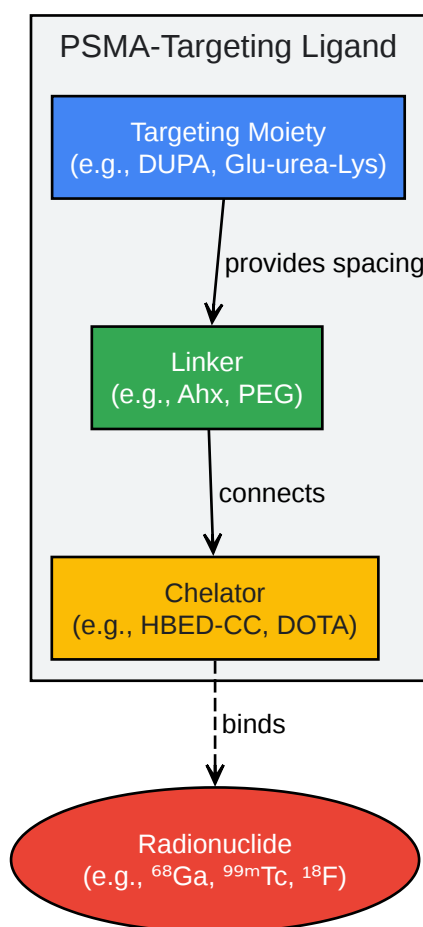

[Click to download full resolution via product page](#)

Caption: Basic components of a PSMA-targeted radiopharmaceutical.

Mechanism of Action and Cellular Interaction

The primary mechanism for both **DUPA** and PSMA-11 involves high-affinity binding to the extracellular domain of the PSMA protein. Molecular docking studies have shown that the carboxylic acid groups of the ligands form electrostatic interactions with arginine and lysine residues within the PSMA active site, while the urea oxygen coordinates with the zinc atoms in the enzyme's core.[1]

Upon binding, the entire PSMA-ligand complex is internalized by the cell through endocytosis. [2] This internalization is a critical feature, as it leads to the accumulation and retention of the attached radionuclide inside the cancer cell, thereby enhancing the signal-to-noise ratio for high-contrast imaging.

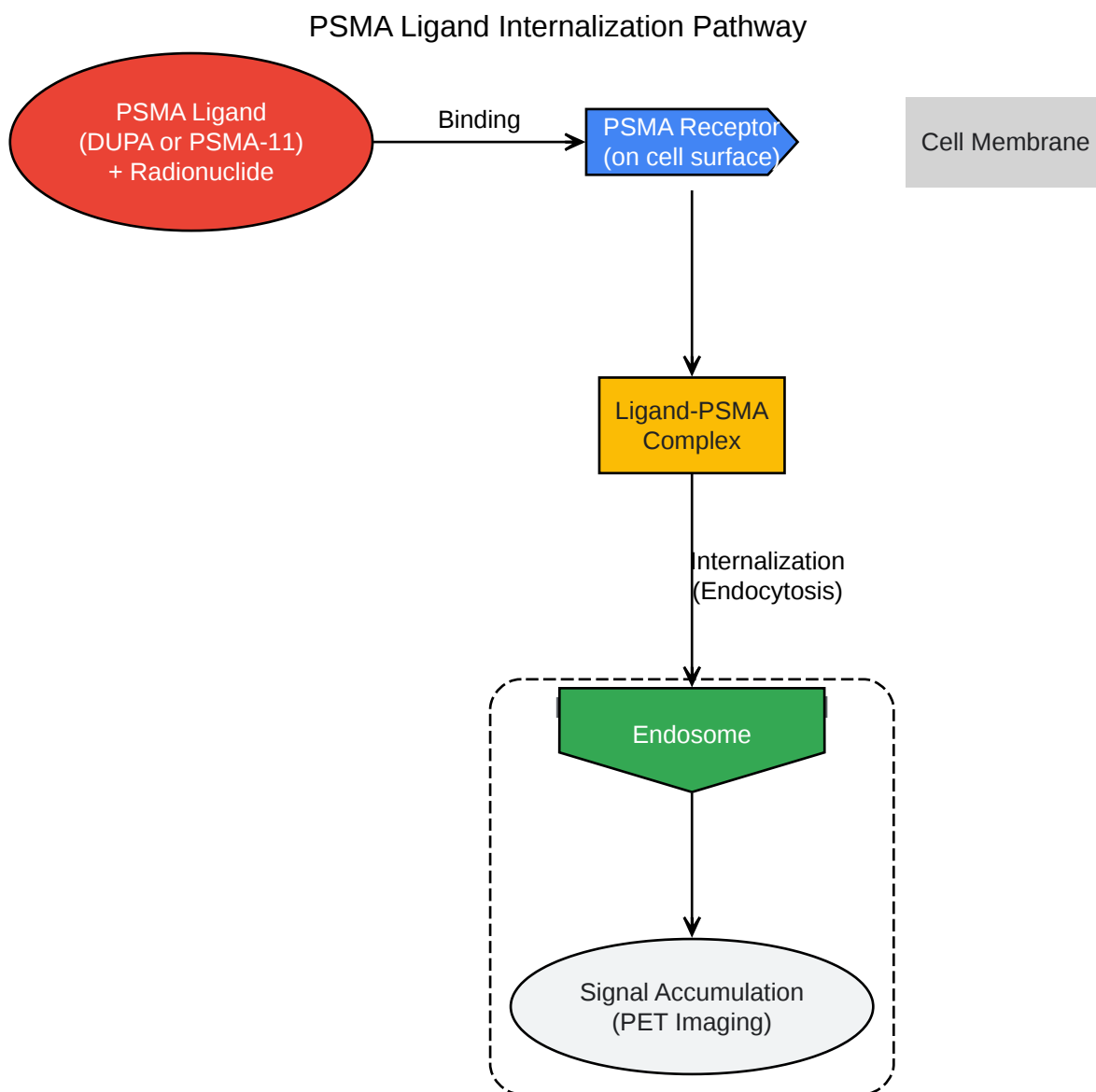

[Click to download full resolution via product page](#)

Caption: Cellular uptake of PSMA-targeting radioligands.

Quantitative Performance Data

The performance of an imaging agent is determined by its binding affinity, target uptake, and clearance from non-target tissues. The following tables summarize key quantitative data for **DUPA**- and PSMA-11-based agents from preclinical and clinical studies.

Table 1: Binding Affinity

| Ligand Conjugate | Cell Line | Binding Affinity (Kd or Ki) | Reference |
|-------------------------------|-----------------|-----------------------------|-----------|
| DUPA-99mTc | LNCaP | KD = 14 nM | [8] |
| DUPA | Purified Enzyme | Ki = 8 nM | [5] |
| [⁶⁸ Ga]Ga-PSMA-11 | LNCaP | Kd = 4.3 ± 0.8 nM | [6] |

Table 2: Preclinical Biodistribution and Tumor Uptake

| Agent | Animal Model | Tumor Uptake (%ID/g) | Time Point | Tumor-to-Muscle Ratio | Reference |
|-------------------------------|-----------------|----------------------|------------|-----------------------|-----------|
| DUPA-99mTc | LNCaP Xenograft | 11.3 | 4 hours | 75:1 | [8] |
| [⁶⁸ Ga]Ga-PSMA-11 | 22Rv1 Xenograft | 4.5 ± 0.7 | 90 minutes | Not Reported | [9][10] |

 Table 3: Clinical Diagnostic Performance of [⁶⁸Ga]Ga-PSMA-11 PET/CT

| Clinical Setting | Sensitivity | Specificity | Accuracy | Reference |
|---|-------------|----------------|----------------|-----------|
| Primary Staging (vs. Conventional Imaging) | 85% | 98% | 92% | [11][12] |
| Biochemical Recurrence (Low PSA ≤ 0.5 ng/mL) | 54.2% - 55% | Not Applicable | Not Applicable | [11] |
| Detection of Index Lesions (vs. mpMRI) | 90.1% | 93% | Not Reported | [11] |
| Lymph Node Metastasis (vs. mpMRI) | ~74% | ~98% | Not Reported | [13] |

Note: Direct head-to-head clinical trials comparing a **DUPA**-based PET agent with [^{68}Ga]Ga-PSMA-11 are limited. The data for **DUPA** is primarily from preclinical or early-phase studies, whereas [^{68}Ga]Ga-PSMA-11 has extensive clinical data.

Experimental Protocols

Detailed methodologies are crucial for the replication and validation of experimental findings. Below are representative protocols for the synthesis and evaluation of these imaging agents.

Protocol 1: Automated Synthesis of [^{68}Ga]Ga-PSMA-11

This protocol describes a common method for producing [^{68}Ga]Ga-PSMA-11 using an automated synthesis module.

Objective: To radiolabel the PSMA-11 precursor with ^{68}Ga from a $^{68}\text{Ge}/^{68}\text{Ga}$ generator.

Materials:

- Modular-Lab PharmTracer synthesis module (or similar)

- Sterile single-use cassette
- $^{68}\text{Ge}/^{68}\text{Ga}$ generator
- PSMA-11 precursor (e.g., 25 μg , GMP grade)
- 0.1N HCl (for elution)
- Sodium acetate buffer (pH 4.5)
- 5N NaCl / 5.5N HCl solution
- C18 Sep-Pak cartridge
- Ethanol and 0.9% NaCl for purification
- Sterile 0.22- μm filter

Procedure:

- Generator Elution: Elute the $^{68}\text{Ge}/^{68}\text{Ga}$ generator with ~ 5 mL of 0.1N HCl to obtain $^{68}\text{Ga}[\text{GaCl}_3]$.
- ^{68}Ga Purification: The eluate is automatically passed through a strong cation exchange (SCX) column within the cassette to trap the ^{68}Ga .
- Elution into Reactor: The purified ^{68}Ga is eluted from the SCX column into the reaction vessel using a small volume (~ 0.8 mL) of a 5N NaCl/5.5N HCl solution.
- Labeling Reaction: The reaction vessel contains the PSMA-11 precursor dissolved in sodium acetate buffer. The mixture is heated to 95°C for 5-7 minutes to facilitate the chelation of ^{68}Ga by the HBED-CC moiety.[\[14\]](#)
- Purification of Product: The crude product is diluted with saline and loaded onto a C18 cartridge. The cartridge traps the $^{68}\text{Ga}[\text{Ga}]\text{-PSMA-11}$ while allowing more polar impurities to pass through.

- Final Formulation: The purified [⁶⁸Ga]Ga-PSMA-11 is eluted from the C18 cartridge with 1 mL of ethanol, diluted with sterile 0.9% NaCl, and passed through a 0.22- μ m sterile filter into a sterile product vial.
- Quality Control: Perform standard quality control tests, including radiochemical purity (by HPLC or TLC), pH, and visual inspection before release.

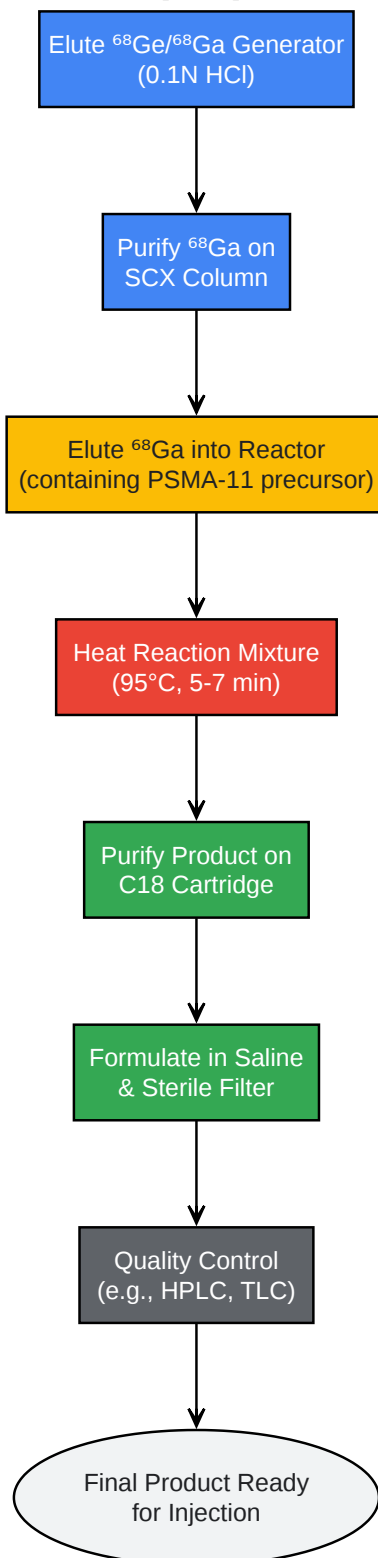
Workflow for Automated [^{68}Ga]Ga-PSMA-11 Synthesis

[Click to download full resolution via product page](#)

Caption: Key steps in the automated synthesis of [^{68}Ga]Ga-PSMA-11.

Protocol 2: Preclinical Biodistribution Study in a Xenograft Model

This protocol outlines a typical procedure to quantify the in vivo distribution of a novel PSMA-targeted radiotracer.

Objective: To determine the uptake and clearance of a radiolabeled PSMA ligand in various tissues of tumor-bearing mice over time.

Materials:

- Immunocompromised mice (e.g., athymic nude mice)
- PSMA-positive human prostate cancer cells (e.g., LNCaP or 22Rv1)
- Radiolabeled PSMA ligand (e.g., **DUPA**-99mTc or [⁶⁸Ga]Ga-PSMA-11)
- Anesthetic
- Gamma counter
- Precision scale

Procedure:

- **Tumor Implantation:** Subcutaneously inject 2-5 million PSMA-positive prostate cancer cells into the flank of each mouse. Allow tumors to grow to a specified size (e.g., 100-200 mm³).
- **Radiotracer Administration:** Anesthetize the tumor-bearing mice. Inject a known activity (e.g., 1-5 MBq) of the radiotracer intravenously via the tail vein.
- **Tissue Harvesting:** At predefined time points (e.g., 30 min, 1h, 2h, 4h, 24h), euthanize a cohort of mice (n=3-5 per time point).
- **Biodistribution Analysis:**
 - Immediately collect blood via cardiac puncture.

- Dissect key organs and tissues (e.g., tumor, muscle, kidneys, liver, spleen, bone, bladder, heart, lungs).
- Weigh each tissue sample accurately.
- Measure the radioactivity in each sample, along with standards of the injected dose, using a calibrated gamma counter.
- Data Calculation:
 - Correct all counts for radioactive decay back to the time of injection.
 - Calculate the percentage of the injected dose per gram of tissue (%ID/g) for each sample.
 - Calculate tumor-to-background ratios (e.g., tumor-to-muscle, tumor-to-blood) by dividing the %ID/g of the tumor by the %ID/g of the background tissue.

Conclusion

Both **DUPA** and PSMA-11 are highly effective targeting moieties for the PSMA receptor, leveraging a similar urea-based pharmacophore for binding.

[⁶⁸Ga]Ga-PSMA-11 has become the undisputed clinical standard for PET imaging of prostate cancer. Its high sensitivity and specificity for detecting primary, recurrent, and metastatic disease are supported by a vast body of clinical evidence, leading to its widespread adoption and FDA approval.^{[7][11]} Its well-established and automated synthesis protocols further solidify its clinical utility.

DUPA serves as a foundational and versatile PSMA-targeting ligand. While **DUPA**-based agents have demonstrated excellent targeting properties in preclinical and early human studies, they have not achieved the same level of widespread clinical adoption for PET imaging as PSMA-11.^{[8][15]} However, the **DUPA** scaffold remains highly relevant and is extensively used in the development of PSMA-targeted therapeutics (theranostics) and other imaging modalities, highlighting its importance in ongoing prostate cancer research.^{[4][5]}

For researchers and drug developers, the choice between these ligands depends on the application: [⁶⁸Ga]Ga-PSMA-11 is the agent of choice for clinically validated PET imaging,

while **DUPA** offers a flexible platform for developing novel diagnostic and therapeutic agents targeting PSMA.

Need Custom Synthesis?

BenchChem offers custom synthesis for rare earth carbides and specific isotopic labeling.

Email: info@benchchem.com or [Request Quote Online](#).

References

- 1. Comparison of prostate-specific membrane antigen ligands in clinical translation research for diagnosis of prostate cancer - PMC [[pmc.ncbi.nlm.nih.gov](https://pubmed.ncbi.nlm.nih.gov/)]
- 2. [⁶⁸Ga]Ga-PSMA-11 in prostate cancer: a comprehensive review - PMC [[pmc.ncbi.nlm.nih.gov](https://pubmed.ncbi.nlm.nih.gov/)]
- 3. [medchemexpress.com](https://www.medchemexpress.com/) [[medchemexpress.com](https://www.medchemexpress.com/)]
- 4. aacrjournals.org [aacrjournals.org]
- 5. pubs.acs.org [pubs.acs.org]
- 6. Preparation of ⁶⁸Ga-PSMA-11 with a Synthesis Module for Micro PET-CT Imaging of PSMA Expression during Prostate Cancer Progression - PMC [[pmc.ncbi.nlm.nih.gov](https://pubmed.ncbi.nlm.nih.gov/)]
- 7. [⁶⁸Ga]Ga-PSMA-11: The First FDA-Approved ⁶⁸Ga-Radiopharmaceutical for PET Imaging of Prostate Cancer - PMC [[pmc.ncbi.nlm.nih.gov](https://pubmed.ncbi.nlm.nih.gov/)]
- 8. pubs.acs.org [pubs.acs.org]
- 9. [researchgate.net](https://www.researchgate.net/) [[researchgate.net](https://www.researchgate.net/)]
- 10. Biodistribution and internal radiation dosimetry of a companion diagnostic radiopharmaceutical, [⁶⁸Ga]PSMA-11, in subcutaneous prostate cancer xenograft model mice - PubMed [pubmed.ncbi.nlm.nih.gov]
- 11. [appliedradiology.com](https://www.appliedradiology.com/) [[appliedradiology.com](https://www.appliedradiology.com/)]
- 12. [m.youtube.com](https://www.youtube.com/) [[m.youtube.com](https://www.youtube.com/)]
- 13. [diagnosticimaging.com](https://www.diagnosticimaging.com/) [[diagnosticimaging.com](https://www.diagnosticimaging.com/)]
- 14. [jnm.snmjournals.org](https://www.jnm.snmjournals.org/) [[jnm.snmjournals.org](https://www.jnm.snmjournals.org/)]
- 15. [researchgate.net](https://www.researchgate.net/) [[researchgate.net](https://www.researchgate.net/)]

- To cite this document: BenchChem. [A Comparative Guide to DUPA and PSMA-11 for Prostate Cancer Imaging]. BenchChem, [2026]. [Online PDF]. Available at: [<https://www.benchchem.com/product/b15542648/docs#a-comparative-guide-to-dupa-and-psma-11-for-prostate-cancer-imaging>]

Disclaimer & Data Validity:

The information provided in this document is for Research Use Only (RUO) and is strictly not intended for diagnostic or therapeutic procedures. While BenchChem strives to provide accurate protocols, we make no warranties, express or implied, regarding the fitness of this product for every specific experimental setup.

Technical Support: The protocols provided are for reference purposes. Unsure if this reagent suits your experiment?

Need Industrial/Bulk Grade? [Request Custom Synthesis Quote](#)

BenchChem

Our mission is to be the trusted global source of essential and advanced chemicals, empowering scientists and researchers to drive progress in science and industry.

Contact

Address: 3281 E Guasti Rd
Ontario, CA 91761, United States
Phone: (601) 213-4426
Email: info@benchchem.com

[Contact our Ph.D. Support Team for a compatibility check](#)