

Unveiling the Molecular Architecture: A Technical Guide to Azide-PEG9-amido-C4-Boc

Author: BenchChem Technical Support Team. **Date:** May 2026

Compound of Interest

Compound Name: Azide-PEG9-amido-C4-Boc

Cat. No.: B15541198

[Get Quote](#)

For Immediate Release

A Deep Dive into the Heterobifunctional Linker Fueling Innovations in Targeted Therapeutics

This technical guide provides an in-depth analysis of **Azide-PEG9-amido-C4-Boc**, a critical heterobifunctional linker employed by researchers, scientists, and drug development professionals. With its unique tripartite structure, this molecule is a cornerstone in the construction of complex bioconjugates and targeted therapies, most notably Proteolysis Targeting Chimeras (PROTACs).

Core Components and Functionality

Azide-PEG9-amido-C4-Boc is meticulously designed with three key functional moieties, each playing a distinct and crucial role in its application.[1][2]

- **Azide Group (N₃):** This terminal group is a highly reactive handle for "click chemistry," a suite of bioorthogonal reactions known for their high efficiency and specificity.[3] It readily participates in Copper(I)-Catalyzed Azide-Alkyne Cycloaddition (CuAAC) and Strain-Promoted Azide-Alkyne Cycloaddition (SPAAC), enabling the precise and stable covalent linkage to molecules containing an alkyne group.[2][4]

- Polyethylene Glycol (PEG) Spacer (PEG9): The nine-unit polyethylene glycol chain serves as a flexible, hydrophilic spacer.[2][3] This PEG linker enhances the solubility and bioavailability of the resulting conjugate, provides spatial separation between the conjugated molecules to mitigate steric hindrance, and can improve pharmacokinetic properties.[1][2]
- Boc-Protected Amine on a C4 Alkyl Chain: The molecule terminates in a primary amine shielded by a tert-butyloxycarbonyl (Boc) protecting group.[1][3] This protecting group is stable under various conditions but can be readily and selectively removed under acidic conditions to reveal the primary amine for subsequent conjugation, typically through amide bond formation.[2]

The interplay of these components allows for a sequential and controlled conjugation strategy, making it an invaluable tool in the modular synthesis of complex molecules like PROTACs.[1][3]

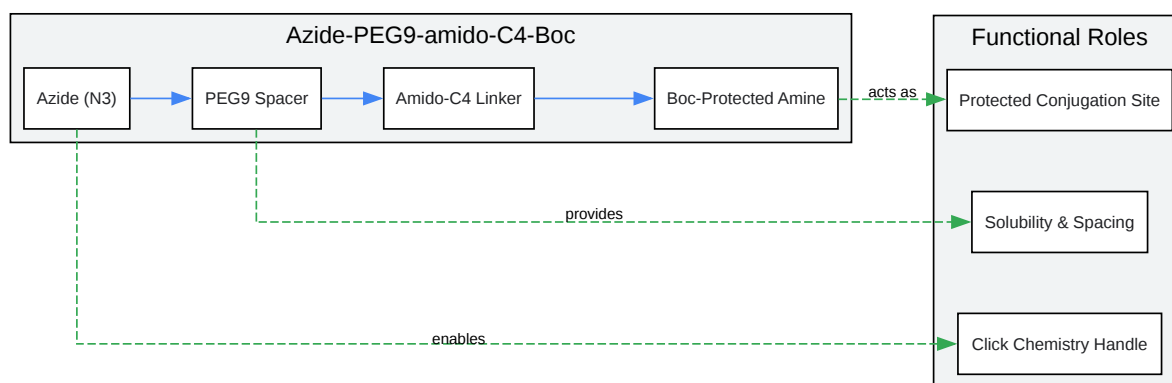

[Click to download full resolution via product page](#)

Functional components of **Azide-PEG9-amido-C4-Boc**.

Quantitative Data Summary

The following table summarizes the key quantitative properties of **Azide-PEG9-amido-C4-Boc**.

Property	Data
Synonyms	5-(Azide-PEG9-ethylcarbamoyl)pentanoic t-butyl ester[3]
Molecular Formula	C ₃₀ H ₅₈ N ₄ O ₁₂ [5]
Molecular Weight	666.80 g/mol [5]
Purity	Typically ≥95% as offered by commercial suppliers.[3]
Appearance	Generally a solid or oil, based on similar PEG compounds.[3]
Solubility	Soluble in common organic solvents such as DMSO and DMF.[3]
Storage	Long-term storage at -20°C is recommended for stability.[3][6] The compound is moisture-sensitive.[3]

Experimental Protocols

Detailed methodologies for the primary applications of **Azide-PEG9-amido-C4-Boc** are provided below. These are generalized protocols and may require optimization for specific applications.

Protocol 1: Copper(I)-Catalyzed Azide-Alkyne Cycloaddition (CuAAC)

This protocol outlines the conjugation of **Azide-PEG9-amido-C4-Boc** to a molecule containing a terminal alkyne.

Materials:

- **Azide-PEG9-amido-C4-Boc**
- Alkyne-containing molecule

- Copper(II) sulfate (CuSO_4)
- Sodium ascorbate
- Copper-binding ligand (e.g., THPTA or TBTA)
- Solvent (e.g., DMSO, DMF, water, or a mixture)
- Degassing equipment (Nitrogen or Argon gas)
- Purification system (e.g., HPLC, size-exclusion chromatography)

Procedure:

- Reactant Preparation:
 - Dissolve the alkyne-functionalized molecule in the chosen reaction buffer to a desired concentration (e.g., 1 mg/mL).[3]
 - Prepare a stock solution of **Azide-PEG9-amido-C4-Boc** in DMSO (e.g., 10 mM).[3]
- Reaction Setup:
 - In a reaction vessel, combine the solution of the alkyne-functionalized molecule with the **Azide-PEG9-amido-C4-Boc** stock solution. A 2 to 10-fold molar excess of the azide linker is commonly used.[3]
 - Add the copper-binding ligand to the mixture. A common ratio is 5 equivalents of ligand to 1 equivalent of copper.[3]
 - Degas the mixture by bubbling with nitrogen or argon gas to prevent the oxidation of the Cu(I) catalyst.
- Reaction Initiation:
 - Add the CuSO_4 stock solution to the reaction mixture.
 - Initiate the cycloaddition by adding a freshly prepared solution of sodium ascorbate.[3]

- Incubation and Monitoring:
 - Incubate the reaction at room temperature for 1-4 hours, or alternatively at 4°C overnight. [3]
 - Monitor the reaction progress using LC-MS or TLC until the starting materials are consumed.
- Purification:
 - Upon completion, purify the conjugate using an appropriate method such as reverse-phase HPLC or silica gel chromatography.

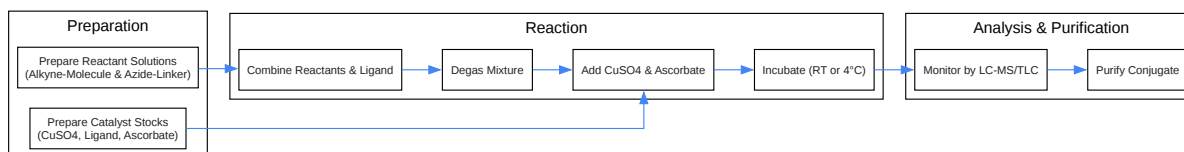

[Click to download full resolution via product page](#)

Workflow for CuAAC bioconjugation.

Protocol 2: Strain-Promoted Azide-Alkyne Cycloaddition (SPAAC)

This protocol describes the copper-free conjugation of **Azide-PEG9-amido-C4-Boc** to a molecule functionalized with a strained alkyne, such as dibenzocyclooctyne (DBCO).

Materials:

- **Azide-PEG9-amido-C4-Boc**
- DBCO-functionalized molecule

- Biocompatible buffer (e.g., PBS, HEPES) or organic solvent (e.g., DMSO, DMF)
- Purification system

Procedure:

- Reactant Preparation:
 - Dissolve **Azide-PEG9-amido-C4-Boc** in the chosen reaction solvent to the desired concentration.
 - Dissolve the DBCO-functionalized molecule in the same solvent.
- Reaction Setup:
 - Mix the **Azide-PEG9-amido-C4-Boc** (typically 1.1 to 1.5 equivalents) with the DBCO-functionalized molecule (1 equivalent).[2]
- Incubation and Monitoring:
 - Incubate the reaction at room temperature. Reaction times can vary from 1 to 12 hours depending on the reactivity of the specific strained alkyne.
 - Monitor the reaction progress by LC-MS or TLC.
- Purification:
 - Once the reaction is complete, purify the final conjugate using a suitable method based on its properties.

Protocol 3: Boc Group Deprotection

This protocol details the removal of the Boc protecting group to expose the terminal amine for further functionalization.

Materials:

- Boc-protected conjugate

- Dichloromethane (DCM)
- Trifluoroacetic acid (TFA)
- Toluene (for removal of residual TFA)

Procedure:

- Reaction Setup:
 - Dissolve the Boc-protected compound in DCM.
 - Cool the solution to 0°C in an ice bath.
 - Add TFA to a final concentration of 20-50% (v/v).[2]
- Reaction and Monitoring:
 - Stir the reaction at 0°C for 30 minutes, then allow it to warm to room temperature.
 - Monitor the deprotection by TLC until the starting material is fully consumed.
- Work-up and Isolation:
 - Concentrate the reaction mixture under reduced pressure to remove the DCM and excess TFA.
 - To remove residual TFA, co-evaporate the residue with toluene three times.[2]
 - The resulting TFA salt of the amine can often be used directly in the subsequent conjugation step.

Application in PROTAC Development

A primary application of **Azide-PEG9-amido-C4-Boc** is in the synthesis of PROTACs.[1][6] PROTACs are bifunctional molecules that recruit a target protein to an E3 ubiquitin ligase, leading to the ubiquitination and subsequent degradation of the target protein by the proteasome.[1] The linker plays a critical role in connecting the target protein-binding ligand

and the E3 ligase-binding ligand, and its length and composition are crucial for the efficacy of the PROTAC.

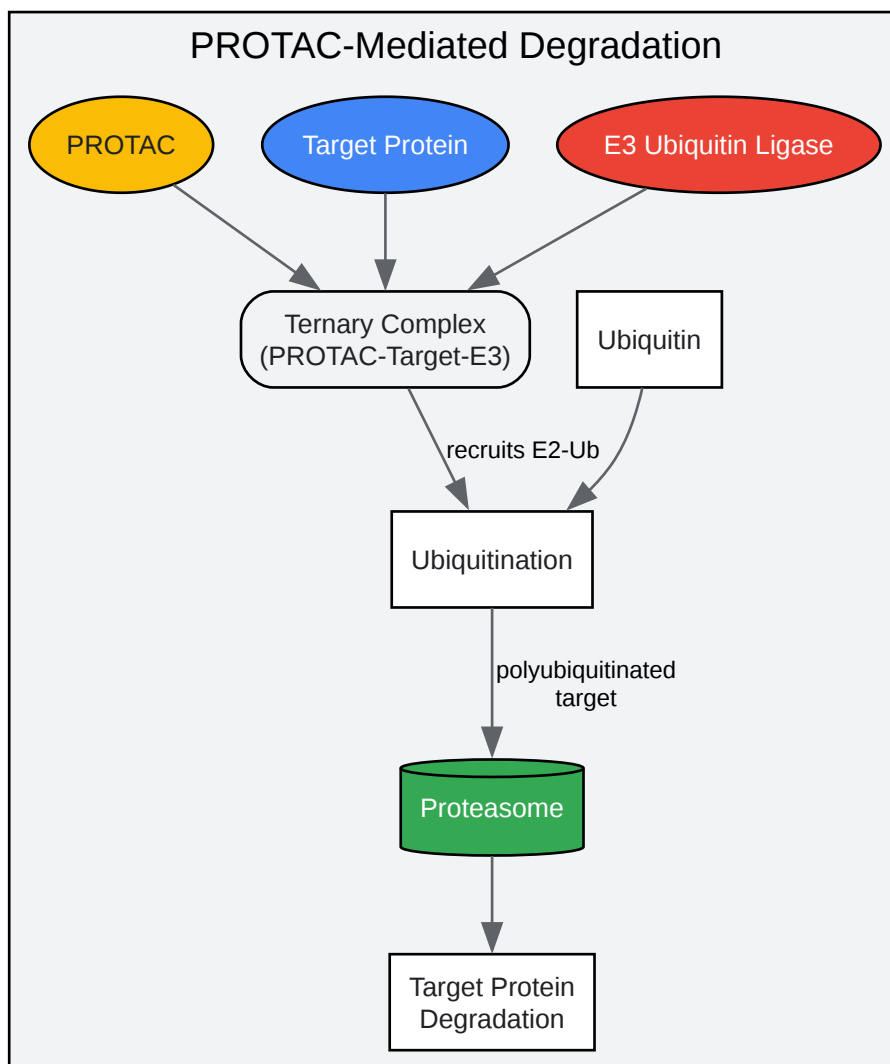

[Click to download full resolution via product page](#)

PROTAC-mediated protein degradation pathway.

Need Custom Synthesis?

BenchChem offers custom synthesis for rare earth carbides and specific isotopic labeling.

Email: info@benchchem.com or [Request Quote Online](#).

References

- [1. benchchem.com \[benchchem.com\]](#)
- [2. benchchem.com \[benchchem.com\]](#)
- [3. benchchem.com \[benchchem.com\]](#)
- [4. medchemexpress.com \[medchemexpress.com\]](#)
- [5. medchemexpress.com \[medchemexpress.com\]](#)
- [6. amsbio.com \[amsbio.com\]](#)
- To cite this document: BenchChem. [Unveiling the Molecular Architecture: A Technical Guide to Azide-PEG9-amido-C4-Boc]. BenchChem, [2026]. [Online PDF]. Available at: [\[https://www.benchchem.com/product/b15541198/docs#unveiling-the-molecular-architecture-a-technical-guide-to-azide-peg9-amido-c4-boc\]](https://www.benchchem.com/product/b15541198/docs#unveiling-the-molecular-architecture-a-technical-guide-to-azide-peg9-amido-c4-boc)

Disclaimer & Data Validity:

The information provided in this document is for Research Use Only (RUO) and is strictly not intended for diagnostic or therapeutic procedures. While BenchChem strives to provide accurate protocols, we make no warranties, express or implied, regarding the fitness of this product for every specific experimental setup.

Technical Support: The protocols provided are for reference purposes. Unsure if this reagent suits your experiment?

Need Industrial/Bulk Grade? [Request Custom Synthesis Quote](#)

BenchChem

Our mission is to be the trusted global source of essential and advanced chemicals, empowering scientists and researchers to drive progress in science and industry.

Contact

Address: 3281 E Guasti Rd
Ontario, CA 91761, United States
Phone: (601) 213-4426
Email: info@benchchem.com

Contact our Ph.D. Support Team for a compatibility check