

# Technical Support Center: Optimizing Pomalidomide-Cyclohexane Degraders

**Author:** BenchChem Technical Support Team. **Date:** April 2026

## Compound of Interest

Compound Name: Pomalidomide-cyclohexane

Cat. No.: B15541094

[Get Quote](#)

This technical support center provides researchers, scientists, and drug development professionals with troubleshooting guides and frequently asked questions (FAQs) for optimizing the linker length of pomalidomide-based degraders targeting cyclohexane-containing proteins.

## Frequently Asked Questions (FAQs)

Q1: What is the fundamental role of the linker in a pomalidomide-based PROTAC?

A1: The linker is a critical component of a Proteolysis Targeting Chimera (PROTAC) that connects the pomalidomide moiety (which binds to the E3 ubiquitin ligase Cereblon, CRBN) to the ligand that binds your cyclohexane-containing target protein.<sup>[1][2]</sup> Its primary role is to bridge the target protein and the E3 ligase, facilitating the formation of a stable and productive ternary complex (Target Protein-PROTAC-E3 Ligase).<sup>[1][3]</sup> The geometry and length of this linker are paramount for inducing ubiquitination and subsequent degradation of the target protein.<sup>[4]</sup>

Q2: How does linker length impact the efficiency of the degrader?

A2: Linker length has a profound influence on the formation and stability of the ternary complex.<sup>[5]</sup>

- Too short: A linker that is too short may cause steric hindrance, preventing the simultaneous binding of the target protein and the E3 ligase.[1]
- Too long: A linker that is too long can result in an unstable and overly flexible ternary complex, leading to inefficient ubiquitination.[1][6]
- Optimal length: An optimal linker length facilitates favorable protein-protein interactions between the target and the E3 ligase, leading to a stable ternary complex and efficient degradation.[3] This optimal length is highly dependent on the specific target protein and E3 ligase pair, often requiring empirical testing to identify a "sweet spot".[1]

Q3: What is the "hook effect" and how does it relate to linker optimization?

A3: The "hook effect" is a phenomenon where the degradation of the target protein decreases at high concentrations of the PROTAC, resulting in a bell-shaped dose-response curve.[3][4][7][8] This occurs because at excessive concentrations, the PROTAC is more likely to form non-productive binary complexes (either with the target protein or the E3 ligase) rather than the productive ternary complex required for degradation.[3][7][8] While not directly caused by the linker, a well-designed linker that promotes positive cooperativity in the ternary complex can help mitigate the hook effect by stabilizing the productive ternary complex over the binary ones.[7]

Q4: Besides length, what other linker properties should be considered?

A4: The composition, rigidity, and attachment points of the linker are also crucial.

- Composition: The chemical makeup of the linker (e.g., PEG, alkyl chains) influences the PROTAC's physicochemical properties, such as solubility and cell permeability.[4][9]
- Rigidity: Introducing rigid elements (like phenyl rings) can reduce the entropic penalty of ternary complex formation.[5]
- Attachment Points: The points where the linker is connected to the pomalidomide and the target ligand can significantly affect the geometry of the ternary complex and, consequently, the degradation potency.[5][10]

## Troubleshooting Guide

Problem 1: My **pomalidomide-cyclohexane** degrader shows low degradation efficiency (low Dmax or high DC50).

- Possible Cause: The linker length is suboptimal, leading to inefficient ternary complex formation.[\[4\]](#)
- Troubleshooting Steps:
  - Synthesize a Linker Library: Design and synthesize a series of degraders with varying linker lengths (e.g., systematically increasing the number of atoms in the linker). A common strategy is to use flexible polyethylene glycol (PEG) or alkyl chains of different lengths.[\[5\]\[9\]](#)
  - Perform Dose-Response Experiments: Test each degrader in a wide dose-response range to determine its DC50 and Dmax values. This will help identify if there is an optimal length "sweet spot".[\[1\]\[7\]](#)
  - Assess Ternary Complex Formation: Use biophysical assays like Surface Plasmon Resonance (SPR) or TR-FRET to directly measure the formation and stability of the ternary complex with different linker-length degraders.[\[2\]\[7\]](#)

Problem 2: I'm observing a significant "hook effect" with my degrader.

- Possible Cause: At high concentrations, your degrader is forming unproductive binary complexes.[\[8\]\[11\]](#)
- Troubleshooting Steps:
  - Confirm with a Wide Dose-Response: Perform a Western blot analysis with a broad range of degrader concentrations (e.g., from picomolar to high micromolar) to clearly visualize the bell-shaped curve.[\[7\]\[8\]](#)
  - Focus on Lower Concentrations: For subsequent experiments, use concentrations at or below the optimal concentration that gives the maximal degradation (Dmax).[\[7\]](#)
  - Enhance Cooperativity: A different linker composition or attachment point might promote more favorable protein-protein interactions, stabilizing the ternary complex and reducing

the hook effect. Consider redesigning the linker to be less flexible or to present different interaction moieties.[7]

Problem 3: The degrader has poor solubility or cell permeability.

- Possible Cause: PROTACs are often large molecules that can have suboptimal physicochemical properties.[3][4] The linker contributes significantly to these properties.
- Troubleshooting Steps:
  - Modify Linker Composition: Introduce more polar groups into the linker, such as ether groups (from PEG linkers), to improve solubility.[7]
  - Check Physicochemical Properties: Use computational tools to predict properties like LogP and polar surface area for your degrader designs.
  - Permeability Assays: Perform a Parallel Artificial Membrane Permeability Assay (PAMPA) to assess cell permeability experimentally.[8]

## Data Presentation: Linker Length Optimization

The following tables summarize hypothetical, yet representative, data for a series of pomalidomide-based degraders targeting a Cyclohexane-containing Protein X (CPX).

Table 1: Impact of Alkyl Linker Length on CPX Degradation

Compound ID	Linker Composition	Linker Length (atoms)	DC50 (nM)	Dmax (%)	Cell Line
CPX-Deg-1	Alkyl Chain	8	>1000	<10	HEK293
CPX-Deg-2	Alkyl Chain	10	250	65	HEK293
CPX-Deg-3	Alkyl Chain	12	35	92	HEK293
CPX-Deg-4	Alkyl Chain	14	48	88	HEK293
CPX-Deg-5	Alkyl Chain	16	150	70	HEK293

Key Observation: A clear "sweet spot" is observed, with a 12-atom alkyl linker providing the most potent degradation. Both shorter and longer linkers result in reduced efficacy.[1]

Table 2: Impact of PEG Linker Length on CPX Degradation

Compound ID	Linker Composition	Linker Length (atoms)	DC50 (nM)	Dmax (%)	Cell Line
CPX-Deg-6	PEG	9 (PEG2)	800	25	HEK293
CPX-Deg-7	PEG	12 (PEG3)	110	85	HEK293
CPX-Deg-8	PEG	15 (PEG4)	25	95	HEK293
CPX-Deg-9	PEG	18 (PEG5)	45	90	HEK293
CPX-Deg-10	PEG	21 (PEG6)	210	75	HEK293

Key Observation: For PEG linkers, a 15-atom linker was optimal. The introduction of ether groups in the PEG linker generally improved the maximal degradation compared to the alkyl linkers, potentially due to better solubility.

## Experimental Protocols

### Protocol 1: Western Blotting for Protein Degradation

This protocol is the primary method to confirm and quantify the degradation of the target protein.[12]

- **Cell Culture and Treatment:** Plate cells (e.g., HEK293) and allow them to adhere overnight. Treat the cells with a range of concentrations of your **pomalidomide-cyclohexane** degrader for a predetermined duration (e.g., 24 hours). Include a vehicle control (e.g., DMSO).
- **Cell Lysis:** Wash the cells with ice-cold PBS and lyse them in RIPA buffer containing protease and phosphatase inhibitors.
- **Protein Quantification:** Determine the total protein concentration of each lysate using a BCA assay.

- SDS-PAGE and Transfer: Separate equal amounts of protein (e.g., 20-30  $\mu\text{g}$ ) on an SDS-PAGE gel and transfer the proteins to a PVDF or nitrocellulose membrane.[10]
- Immunoblotting:
  - Block the membrane with 5% non-fat milk or BSA in TBST for 1 hour.
  - Incubate the membrane with a primary antibody specific to your cyclohexane-containing target protein overnight at 4°C.
  - Wash the membrane with TBST and incubate with an HRP-conjugated secondary antibody for 1 hour at room temperature.[10]
  - Incubate with an antibody for a loading control (e.g., GAPDH,  $\beta$ -actin).
- Detection: Visualize the protein bands using an enhanced chemiluminescence (ECL) substrate and an imaging system. Quantify the band intensity using software like ImageJ.
- Data Analysis: Normalize the target protein band intensity to the loading control. Calculate the percentage of degradation relative to the vehicle control to determine DC50 and Dmax values.

## Protocol 2: Ternary Complex Formation Assay (TR-FRET)

This assay measures the PROTAC-induced proximity of the target protein and the E3 ligase.[7]

- Reagents: Obtain purified, tagged versions of your target protein (e.g., His-tagged) and the E3 ligase complex (e.g., biotinylated CRBN/DDB1). Also required are fluorescently labeled antibodies (e.g., anti-His-Terbium and Streptavidin-d2).
- Assay Setup: In a microplate, add a constant concentration of the purified target protein and E3 ligase complex to each well in an appropriate assay buffer.[7]
- PROTAC Addition: Add serial dilutions of the **pomalidomide-cyclohexane** degraders to the wells. Include a control with no degrader.
- Incubation: Incubate the plate at room temperature for a specified time (e.g., 60 minutes) to allow for complex formation.

- **Detection:** Measure the Time-Resolved Fluorescence Resonance Energy Transfer (TR-FRET) signal on a compatible plate reader.
- **Data Analysis:** Plot the FRET signal as a function of degrader concentration. An increase in the FRET signal indicates the formation of the ternary complex.

## Visualizations

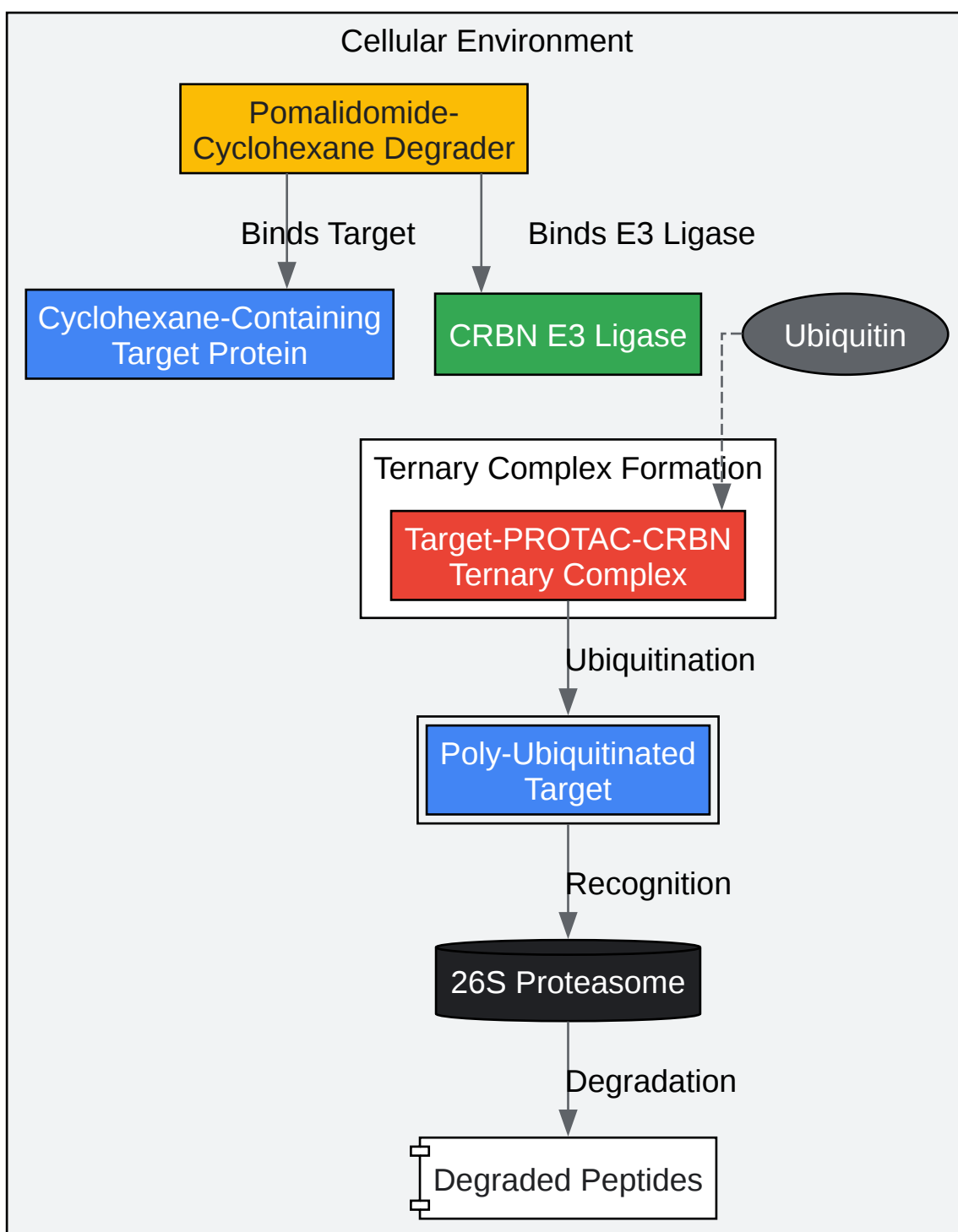

[Click to download full resolution via product page](#)

Caption: Mechanism of action for a **pomalidomide-cyclohexane** degrader.

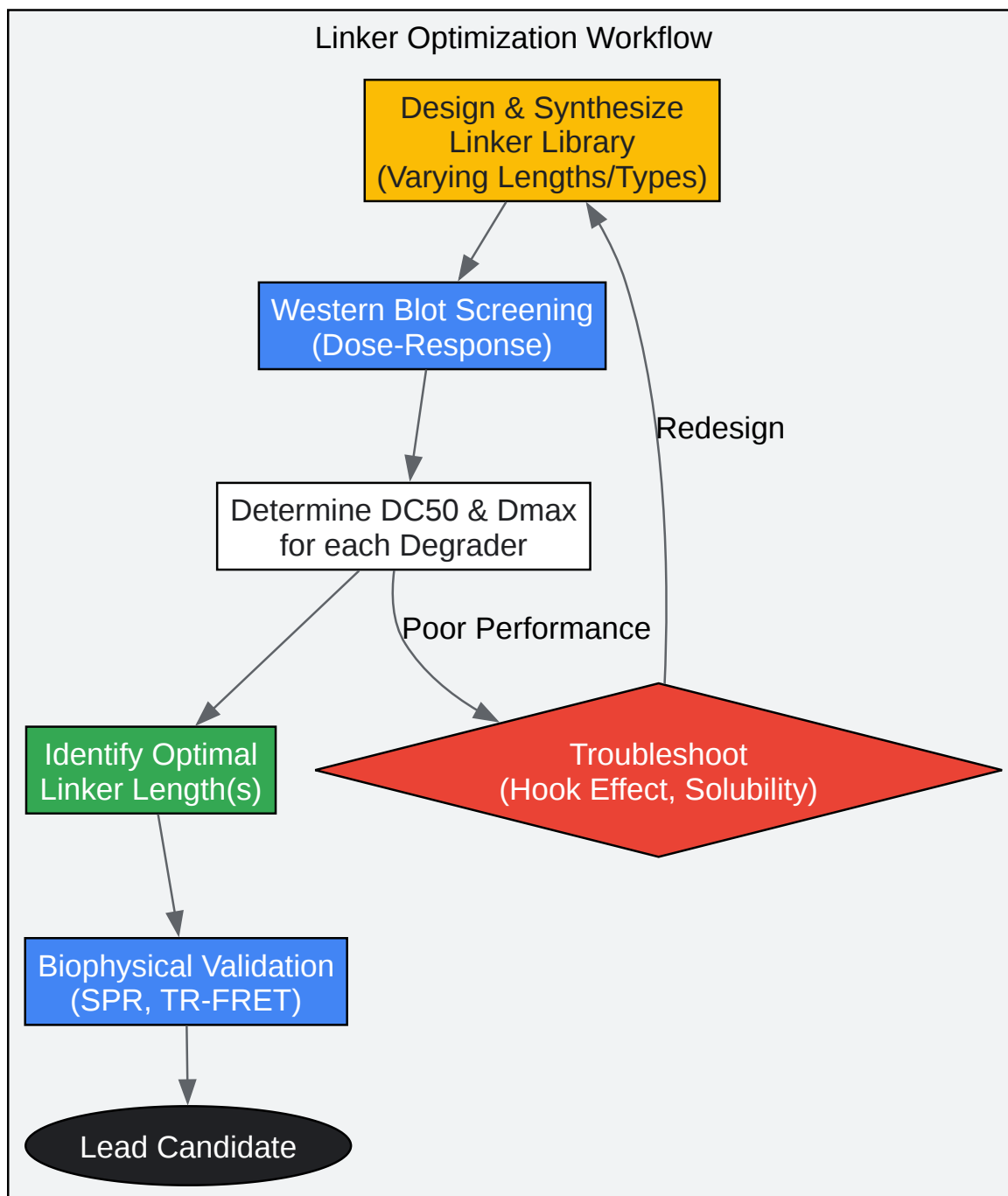

[Click to download full resolution via product page](#)

Caption: Experimental workflow for linker length optimization.

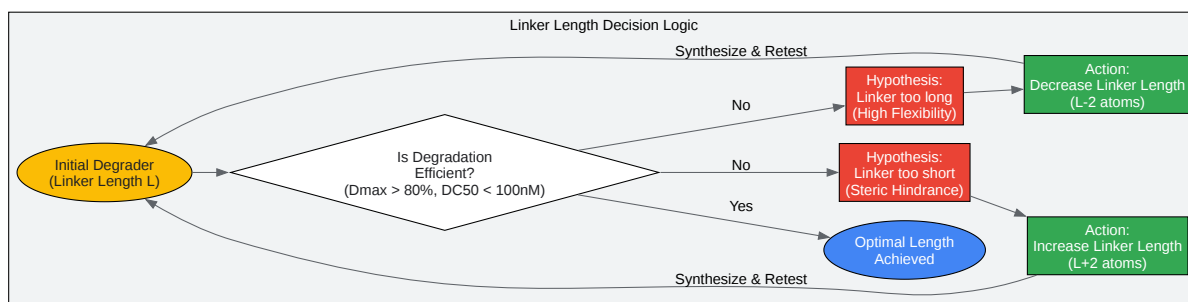

[Click to download full resolution via product page](#)

Caption: Troubleshooting logic for suboptimal linker length.

### Need Custom Synthesis?

BenchChem offers custom synthesis for rare earth carbides and specific isotopic labeling.

Email: [info@benchchem.com](mailto:info@benchchem.com) or [Request Quote Online](#).

## References

- 1. [benchchem.com](https://www.benchchem.com) [benchchem.com]
- 2. [benchchem.com](https://www.benchchem.com) [benchchem.com]
- 3. From Conception to Development: Investigating PROTACs Features for Improved Cell Permeability and Successful Protein Degradation - PMC [pmc.ncbi.nlm.nih.gov]
- 4. [benchchem.com](https://www.benchchem.com) [benchchem.com]
- 5. [researchgate.net](https://www.researchgate.net) [researchgate.net]

- [6. Construction of PROTAC-Mediated Ternary Complex Structure Distribution Profiles Using Extensive Conformational Search - PMC \[pmc.ncbi.nlm.nih.gov\]](#)
- [7. benchchem.com \[benchchem.com\]](#)
- [8. benchchem.com \[benchchem.com\]](#)
- [9. Current strategies for the design of PROTAC linkers: a critical review - PMC \[pmc.ncbi.nlm.nih.gov\]](#)
- [10. benchchem.com \[benchchem.com\]](#)
- [11. Critical assessment of targeted protein degradation as a research tool and pharmacological modality - PMC \[pmc.ncbi.nlm.nih.gov\]](#)
- [12. benchchem.com \[benchchem.com\]](#)
- To cite this document: BenchChem. [Technical Support Center: Optimizing Pomalidomide-Cyclohexane Degradation]. BenchChem, [2026]. [Online PDF]. Available at: [\[https://www.benchchem.com/product/b15541094/docs#technical-support-center-optimizing-pomalidomide-cyclohexane-degraders\]](https://www.benchchem.com/product/b15541094/docs#technical-support-center-optimizing-pomalidomide-cyclohexane-degraders)

---

### Disclaimer & Data Validity:

The information provided in this document is for Research Use Only (RUO) and is strictly not intended for diagnostic or therapeutic procedures. While BenchChem strives to provide accurate protocols, we make no warranties, express or implied, regarding the fitness of this product for every specific experimental setup.

**Technical Support:** The protocols provided are for reference purposes. Unsure if this reagent suits your experiment?

**Need Industrial/Bulk Grade?** [Request Custom Synthesis Quote](#)

## BenchChem

Our mission is to be the trusted global source of essential and advanced chemicals, empowering scientists and researchers to drive progress in science and industry.

### Contact

Address: 3281 E Guasti Rd  
Ontario, CA 91761, United States  
Phone: (601) 213-4426  
Email: [info@benchchem.com](mailto:info@benchchem.com)

Contact our Ph.D. Support Team for a compatibility check