

Technical Support Center: Optimizing Cbz-Cl Reactions with Piperidine

Author: BenchChem Technical Support Team. **Date:** April 2026

Compound of Interest

Compound Name: Cbz-Pip-2C-Pip-C-Pip

Cat. No.: B15541359

[Get Quote](#)

This technical support center is designed for researchers, scientists, and drug development professionals to provide troubleshooting guidance and frequently asked questions (FAQs) for the N-benzyloxycarbonyl (Cbz) protection of piperidine using benzyl chloroformate (Cbz-Cl).

Frequently Asked Questions (FAQs)

Q1: What are the standard reaction conditions for the Cbz protection of piperidine?

A typical procedure involves dissolving piperidine and a base, such as triethylamine or sodium bicarbonate, in a suitable solvent like dichloromethane (DCM) at 0 °C.^[1] Benzyl chloroformate (Cbz-Cl) is then added dropwise to the cooled solution. The reaction is often stirred for several hours, allowing it to gradually warm to room temperature.^{[1][2]}

Q2: My reaction is sluggish or incomplete. What are the potential causes and solutions?

Incomplete reactions can stem from several factors:

- **Reagent Quality:** Cbz-Cl is highly sensitive to moisture and can degrade into benzyl alcohol and HCl.^[1] It is crucial to use a fresh bottle or a recently opened one that has been stored

under an inert atmosphere.[1] The purity of piperidine and the base is also important; ensure they are free from excess moisture.[1]

- Temperature: While the reaction is typically initiated at 0 °C to control its exothermic nature, very low temperatures might slow down the reaction rate.[1] If the reaction is sluggish, allowing it to warm to room temperature for a few hours can help drive it to completion.[1][3]
- Reaction Time: Depending on the scale and specific conditions, the reaction may require more time than initially anticipated. It is recommended to monitor the reaction's progress using Thin Layer Chromatography (TLC).[1]
- Mixing: In biphasic systems (e.g., DCM/water), efficient stirring is essential to ensure proper contact between the reactants.[1]

Q3: I'm observing multiple spots on my TLC plate. What are the likely side products and how can I minimize them?

Common side products include:

- N,N'-Dibenzoyloxycarbonyl-piperidine (Di-Cbz-piperidine): This occurs when the initially formed N-Cbz-piperidine reacts with another molecule of Cbz-Cl. To minimize this, use a stoichiometric amount or only a slight excess (e.g., 1.05 equivalents) of Cbz-Cl.[3] Slow, dropwise addition of Cbz-Cl at a low temperature helps maintain a low concentration of the electrophile, further reducing the likelihood of this side product.[3]
- Benzyl Alcohol: This is a common impurity in Cbz-Cl and can also form from its decomposition in the presence of moisture.[1][3] Using fresh, high-purity Cbz-Cl and ensuring anhydrous reaction conditions can mitigate its presence.[3]
- Dibenzyl Carbonate: This can form from the decomposition of Cbz-Cl or its reaction with benzyl alcohol.[3]

Q4: What is the optimal choice of base and solvent for this reaction?

The choice of base and solvent can significantly impact the reaction's efficiency and ease of workup.

- **Bases:** Both inorganic and organic bases can be used. Inorganic bases like sodium bicarbonate (NaHCO_3) and sodium carbonate (Na_2CO_3) are inexpensive and easily removed during the aqueous workup.^[1] Organic bases such as triethylamine (TEA) and diisopropylethylamine (DIPEA) are also common choices, though they can sometimes be more challenging to remove completely during purification.^[1] The primary role of the base is to neutralize the hydrochloric acid (HCl) generated during the reaction.^[4]
- **Solvents:** Dichloromethane (DCM) is a widely used solvent due to the good solubility of both the starting materials and the product.^[1] Other options include ethyl acetate, tetrahydrofuran (THF), and acetonitrile.^[1] For biphasic systems, a combination of an organic solvent and water is used.^[1]

Q5: How should I purify the N-Cbz-piperidine product?

Standard workup involves washing the reaction mixture with 1 M HCl to remove any unreacted piperidine, followed by a wash with a saturated sodium bicarbonate solution and then brine.^[1] The organic layer is then dried over an anhydrous salt like sodium sulfate (Na_2SO_4), filtered, and concentrated under reduced pressure.^{[1][2]}

If the crude product is an oil and does not crystallize, purification can be achieved through:

- **Column Chromatography:** A silica gel column with a gradient elution of ethyl acetate in hexanes is typically effective for separating the product from impurities.^[1]
- **Salt Formation:** Since the product contains a basic piperidine nitrogen, treating a solution of the product with HCl in a solvent like diethyl ether can induce the crystallization of the hydrochloride salt. The free base can then be regenerated by treatment with a mild base.^[1]

Troubleshooting Guide

Issue	Potential Cause	Recommended Action
Low to No Product Formation	1. Inactive Cbz-Cl: Degraded due to moisture exposure.[1] 2. Inadequate Base: Insufficient amount or inappropriate type of base. 3. Low Reaction Temperature: Significantly slowed reaction rate.	1. Use a fresh bottle of Cbz-Cl and ensure all glassware is dry.[1] 2. Use at least two equivalents of a suitable base (e.g., NaHCO ₃ , TEA). 3. Allow the reaction to warm to room temperature after the initial addition of Cbz-Cl at 0°C.[1][3]
Formation of White Precipitate (other than product)	Piperidine Hydrochloride Salt: If the piperidine starting material is a hydrochloride salt, it may not be fully neutralized.	Ensure sufficient base is added to neutralize the salt and the HCl generated during the reaction.
Reaction Mixture Turns Yellow/Brown	1. Decomposition of Cbz-Cl: Can occur at elevated temperatures or in the presence of impurities. 2. Side Reactions: Unwanted side reactions leading to colored byproducts.	1. Perform the reaction at low temperatures (0 °C is ideal) and use fresh, high-purity Cbz-Cl. 2. Carefully control the addition of Cbz-Cl to avoid localized heating.
Significant Amount of Unreacted Piperidine	Incomplete Reaction: Insufficient reaction time or deactivation of Cbz-Cl.	1. Allow the reaction to stir for a longer period, monitoring by TLC.[3] 2. Ensure the Cbz-Cl is of high quality.[3]
High Levels of Di-Cbz-piperidine Detected	Excess Cbz-Cl or Prolonged Reaction Time: The product reacts further with Cbz-Cl.[3]	1. Use a stoichiometric amount or a very slight excess (e.g., 1.05 eq) of Cbz-Cl.[3] 2. Monitor the reaction closely by TLC and quench it as soon as the piperidine is consumed.[3] 3. Add Cbz-Cl dropwise at 0 °C.[3]
Presence of Benzyl Alcohol	Hydrolysis of Cbz-Cl: Due to the presence of water.[3]	Use anhydrous solvents and reagents, and conduct the

reaction under an inert
atmosphere.[1]

Data Presentation: Comparison of Reaction Conditions

Parameter	Condition 1: Inorganic Base in Biphasic System	Condition 2: Organic Base in Anhydrous System	Considerations
Base	NaHCO ₃ , Na ₂ CO ₃ , K ₂ CO ₃ [1]	Triethylamine (TEA), DIPEA[1]	Inorganic bases are easily removed during workup. Organic bases may require more rigorous purification.[1]
Solvent	Dichloromethane (DCM) / Water, Ethyl Acetate / Water	Dichloromethane (DCM), THF, Acetonitrile[1]	DCM is a versatile choice for both systems. Anhydrous conditions are critical for the organic base system to prevent Cbz-Cl hydrolysis.
Temperature	0 °C to Room Temperature[1]	0 °C to Room Temperature[1]	Low temperature is generally preferred to control the reaction and minimize side products.[1][3]
Stoichiometry (Cbz-Cl:Piperidine)	1.05 : 1.0	1.05 : 1.0	A slight excess of Cbz-Cl can drive the reaction to completion, but a large excess increases the risk of di-Cbz-piperidine formation.[3]

Experimental Protocols

Protocol 1: Cbz Protection of Piperidine using Sodium Bicarbonate

- Dissolution: Dissolve piperidine (1.0 eq) in a mixture of dichloromethane (DCM) and water.
- Base Addition: Cool the solution to 0 °C in an ice bath and add sodium bicarbonate (2.5 eq) portion-wise, ensuring the temperature remains below 10 °C.[1]
- Addition of Cbz-Cl: Add a solution of benzyl chloroformate (1.05 eq) in DCM dropwise to the vigorously stirred solution at 0 °C.[1]
- Reaction: Allow the reaction mixture to slowly warm to room temperature and stir for 3-5 hours. Monitor the reaction progress by TLC.[1]
- Workup: Separate the organic layer. Extract the aqueous layer with DCM.
- Washing: Combine the organic layers and wash with 1 M HCl, followed by saturated sodium bicarbonate solution, and finally brine.[1]
- Drying and Concentration: Dry the organic layer over anhydrous sodium sulfate, filter, and concentrate under reduced pressure to yield the crude product.[1][2]
- Purification: Purify the crude product by column chromatography on silica gel or by recrystallization if it solidifies.

Protocol 2: Cbz Protection of Piperidine using Triethylamine

- Dissolution: To a solution of piperidine (1.0 eq) and triethylamine (1.2 eq) in anhydrous DCM at 0 °C under an inert atmosphere, add benzyl chloroformate (1.1 eq) dropwise.
- Reaction: Stir the reaction at room temperature for 3-5 hours.
- Workup: Wash the reaction mixture with 1 M HCl, saturated aqueous NaHCO₃, and brine.
- Drying and Concentration: Dry the organic layer over Na₂SO₄, filter, and concentrate to give the crude N-Cbz-piperidine.
- Purification: Purify the crude product as needed by column chromatography.

Visualizations

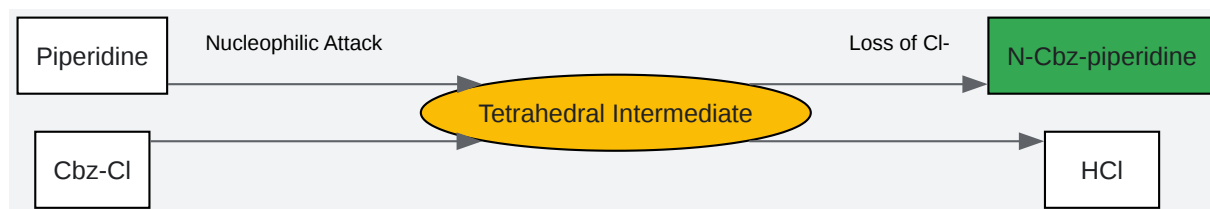

[Click to download full resolution via product page](#)

Caption: Reaction mechanism for the N-Cbz protection of piperidine.

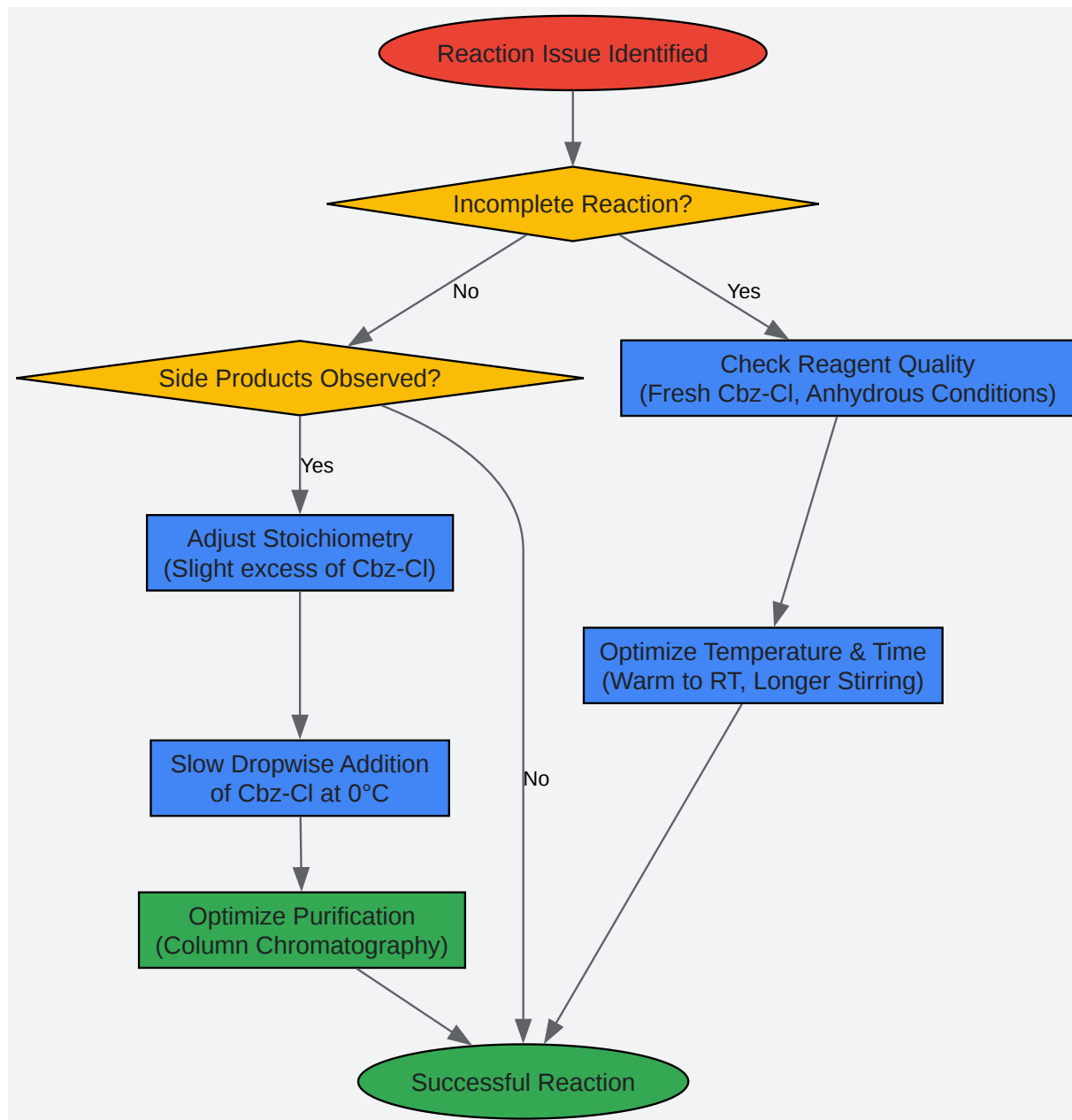

[Click to download full resolution via product page](#)

Caption: A workflow for troubleshooting common issues in the Cbz protection of piperidine.

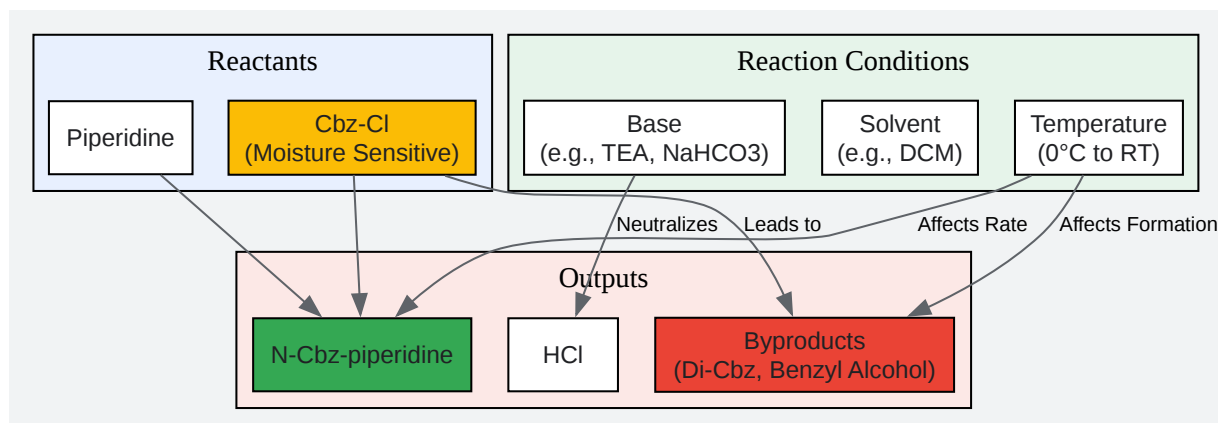

[Click to download full resolution via product page](#)

Caption: Logical relationships of components in the Cbz protection of piperidine.

Need Custom Synthesis?

BenchChem offers custom synthesis for rare earth carbides and specific isotopic labeling.

Email: info@benchchem.com or [Request Quote Online](#).

References

- 1. [benchchem.com](https://www.benchchem.com) [benchchem.com]
- 2. [benchchem.com](https://www.benchchem.com) [benchchem.com]
- 3. [benchchem.com](https://www.benchchem.com) [benchchem.com]
- 4. [benchchem.com](https://www.benchchem.com) [benchchem.com]
- To cite this document: BenchChem. [Technical Support Center: Optimizing Cbz-Cl Reactions with Piperidine]. BenchChem, [2026]. [Online PDF]. Available at: [\[https://www.benchchem.com/product/b15541359/docs#technical-support-center-optimizing-cbz-cl-reactions-with-piperidine\]](https://www.benchchem.com/product/b15541359/docs#technical-support-center-optimizing-cbz-cl-reactions-with-piperidine)

Disclaimer & Data Validity:

The information provided in this document is for Research Use Only (RUO) and is strictly not intended for diagnostic or therapeutic procedures. While BenchChem strives to provide accurate protocols, we make no warranties, express or implied, regarding the fitness of this product for every specific experimental setup.

Technical Support: The protocols provided are for reference purposes. Unsure if this reagent suits your experiment?

Need Industrial/Bulk Grade? [Request Custom Synthesis Quote](#)

BenchChem

Our mission is to be the trusted global source of essential and advanced chemicals, empowering scientists and researchers to drive progress in science and industry.

Contact

Address: 3281 E Guasti Rd
Ontario, CA 91761, United States
Phone: (601) 213-4426
Email: info@benchchem.com

[Contact our Ph.D. Support Team for a compatibility check](#)