

Site-Selective Protein Modification with PEG Linkers: Application Notes and Protocols

Author: BenchChem Technical Support Team. **Date:** April 2026

Compound of Interest

Compound Name: Hydroxy-PEG4-CH2-Boc

Cat. No.: B15541441

[Get Quote](#)

For Researchers, Scientists, and Drug Development Professionals

Introduction

The covalent attachment of polyethylene glycol (PEG) chains to therapeutic proteins, a process known as PEGylation, is a well-established strategy to enhance their pharmacokinetic and pharmacodynamic properties. Benefits of PEGylation include improved protein stability, increased water solubility, prolonged plasma half-life, and reduced immunogenicity and antigenicity.[1][2][3][4] However, non-specific PEGylation can lead to a heterogeneous mixture of products with reduced biological activity.[5][6] Site-selective PEGylation addresses this challenge by attaching PEG linkers to specific amino acid residues, resulting in a more homogeneous product with preserved function.[5][7][8] This document provides detailed application notes and protocols for key site-selective protein modification strategies with PEG linkers.

Key Strategies for Site-Selective PEGylation

Several methods have been developed to achieve site-selective PEGylation, primarily targeting specific amino acid residues or incorporating unnatural amino acids. The choice of strategy

depends on the protein's structure, the desired degree of modification, and the required retention of biological activity.

Cysteine-Reactive PEGylation

This is one of the most common methods for site-specific PEGylation due to the low natural abundance of free cysteine residues in proteins.[7] By genetically engineering a single reactive cysteine at a desired location, a PEG-maleimide derivative can be specifically attached.[6][7]

Advantages:

- High selectivity for free thiol groups.
- Relatively straightforward to implement if a free cysteine is available or can be introduced.

Disadvantages:

- Requires the absence of other reactive free cysteines.
- The maleimide linkage can sometimes be unstable under certain conditions.[9]

Lysine-Reactive PEGylation

Lysine residues are abundant on the surface of most proteins, making them a common target for PEGylation.[1][2] Site-selectivity can be achieved by controlling the reaction pH to target the α -amino group at the N-terminus, which generally has a lower pKa than the ϵ -amino groups of lysine side chains.[9]

Advantages:

- Lysine residues are often surface-exposed.
- A well-established chemistry using PEG-NHS esters.[1]

Disadvantages:

- Can lead to a heterogeneous mixture if not properly controlled.[6]

- Modification of lysine residues may interfere with protein activity if they are located in the active site.

N-Terminal Selective PEGylation

Targeting the N-terminal α -amino group offers a single, specific modification site. This can be achieved through reductive amination using a PEG-aldehyde at a controlled pH (typically below 7.0) where the N-terminal amine is more reactive than lysine side chains.[9][10]

Advantages:

- Provides a single, predictable site of modification.
- Generally preserves the biological activity of the protein.

Disadvantages:

- Requires the N-terminus to be accessible and not critical for biological function.[9]

Disulfide Bridging PEGylation

This technique targets native disulfide bonds within a protein. The disulfide bond is first reduced to yield two free cysteine residues, which are then re-bridged with a bifunctional PEG reagent, such as a PEG-bis-sulfone.[7][10]

Advantages:

- Maintains the native protein structure by re-bridging the disulfide bond.[7]
- Offers high site-specificity.

Disadvantages:

- Requires the presence of an accessible disulfide bond.
- The reduction and re-bridging steps can be challenging to optimize.

Unnatural Amino Acid (UAA) Incorporation

This advanced method involves genetically encoding an unnatural amino acid with a unique reactive handle (e.g., an azide or alkyne group) at a specific site in the protein.[10][11] A PEG linker with a complementary reactive group can then be attached via bioorthogonal "click" chemistry.[11][12]

Advantages:

- Extremely high site-specificity.
- The bioorthogonal reaction is highly efficient and occurs under mild conditions.

Disadvantages:

- Requires a more complex workflow involving molecular biology techniques.
- Can be costly and technically demanding.[13]

Quantitative Data Summary

The following tables summarize key quantitative data from various site-selective PEGylation studies. This data can help researchers compare the efficiency and impact of different methods.

Table 1: Comparison of Site-Selective PEGylation Methods

PEGylation Strategy	Target Residue/ Site	Typical PEG Reagent	Selectivity	Reported Yield/Efficiency	Impact on Activity	Reference
Cysteine-Reactive	Engineered Cysteine	PEG-Maleimide	High	>90%	Can be high if site is chosen carefully. [14]	[6][7]
Lysine-Reactive (N-Terminal)	N-terminal α -amine	PEG-NHS Ester (at controlled pH)	Moderate to High	~85% N-terminal modification. [9]	Generally preserved.	[1][9]
N-Terminal Reductive Amination	N-terminal α -amine	PEG-Aldehyde	High	58.3% mono-PEGylated conjugate. [15]	Generally preserved. [9]	[9][10]
Disulfide Bridging	Cysteine-Cysteine	PEG-bis-sulfone	High	Not specified	Structure is preserved. [7]	[7][10]
Unnatural Amino Acid	p-azidophenylalanine	Alkyne-PEG	Very High	Not specified	Highly retained bioactivity. [12]	[11][12]

Table 2: Impact of PEGylation on Protein Properties

Protein	PEGylation Site	PEG Size (kDa)	Change in Half-life	Retention of In Vitro Activity	Reference
Interferon α -2a	Lysine	40 (branched)	Increased	7%	[16]
Granulocyte-Macrophage Colony-Stimulating Factor (GM-CSF)	Engineered Cysteine (A3C)	10, 20, 40	Up to 47-fold longer	Minimal loss	[14]
Glucagon-like peptide-1 (GLP-1)	C-terminal Cysteine	20	Increased	Similar in vivo effects to unmodified	[6]
α -1 Antitrypsin	Engineered Cysteine	5, 10, 20, 40	Not specified	No significant change	[17]

Experimental Protocols

The following are generalized protocols for key site-selective PEGylation methods. Researchers should optimize these protocols for their specific protein and PEG reagent.

Protocol 1: Site-Selective Cysteine PEGylation

Objective: To selectively conjugate a PEG-maleimide linker to an engineered free cysteine residue on a protein.

Materials:

- Protein with a single, accessible free cysteine
- PEG-Maleimide (e.g., 5, 10, or 20 kDa)
- Reaction Buffer: Phosphate-buffered saline (PBS), pH 6.5-7.5

- Quenching Reagent: L-cysteine or β -mercaptoethanol
- Purification System: Size-exclusion chromatography (SEC) or Ion-exchange chromatography (IEX)

Workflow Diagram:

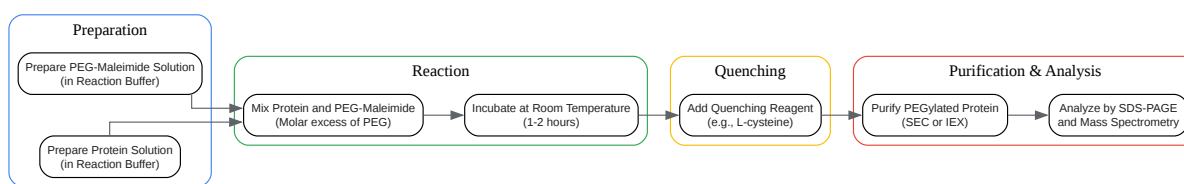

[Click to download full resolution via product page](#)

Caption: Workflow for site-selective cysteine PEGylation.

Procedure:

- Protein Preparation: Dissolve the protein in the reaction buffer to a final concentration of 1-10 mg/mL. Ensure the buffer is degassed to prevent oxidation of the cysteine residue.
- PEG Reagent Preparation: Immediately before use, dissolve the PEG-maleimide in the reaction buffer to achieve a 5- to 20-fold molar excess over the protein.
- PEGylation Reaction: Add the PEG-maleimide solution to the protein solution. Incubate the reaction mixture at room temperature for 1-2 hours with gentle stirring.
- Quenching the Reaction: To stop the reaction, add a quenching reagent (e.g., L-cysteine) to a final concentration of 20-50 mM to react with any excess PEG-maleimide.
- Purification: Purify the PEGylated protein from unreacted PEG and protein using size-exclusion or ion-exchange chromatography.

- Analysis: Analyze the purified product by SDS-PAGE to confirm the increase in molecular weight and by mass spectrometry to verify the site of modification.

Protocol 2: N-Terminal Selective PEGylation via Reductive Amination

Objective: To selectively conjugate a PEG-aldehyde linker to the N-terminal α -amino group of a protein.

Materials:

- Protein with an accessible N-terminus
- PEG-Aldehyde
- Reaction Buffer: Sodium phosphate buffer, pH 6.0-7.0
- Reducing Agent: Sodium cyanoborohydride (NaCNBH_3)
- Purification System: SEC or IEX

Workflow Diagram:

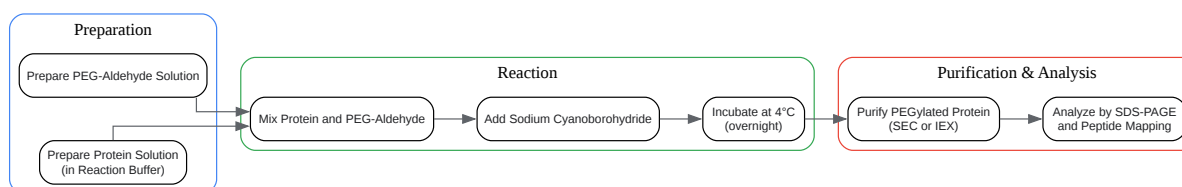

[Click to download full resolution via product page](#)

Caption: Workflow for N-terminal selective PEGylation.

Procedure:

- **Protein and PEG Preparation:** Dissolve the protein in the reaction buffer. Add the PEG-aldehyde to the protein solution at a desired molar ratio.
- **Initiate Reaction:** Add the reducing agent, sodium cyanoborohydride, to the mixture. Caution: Sodium cyanoborohydride is toxic and should be handled in a fume hood.[9]
- **Incubation:** Incubate the reaction mixture overnight at 4°C with gentle stirring.
- **Purification:** Remove unreacted PEG and byproducts by SEC or IEX.
- **Analysis:** Characterize the final product using SDS-PAGE and peptide mapping to confirm N-terminal modification.

Protocol 3: PEGylation via Unnatural Amino Acid Incorporation

Objective: To site-selectively PEGylate a protein containing an unnatural amino acid with a bioorthogonal handle. This protocol assumes the protein has been expressed with a p-azidophenylalanine residue.

Materials:

- Protein containing p-azidophenylalanine
- Alkyne-PEG
- Copper(I) catalyst (e.g., CuSO₄ and a reducing agent like sodium ascorbate, or a pre-formed Cu(I) complex)
- Copper-chelating ligand (e.g., THPTA)
- Reaction Buffer: PBS, pH 7.4
- Purification System: SEC or IEX

Signaling Pathway Diagram:

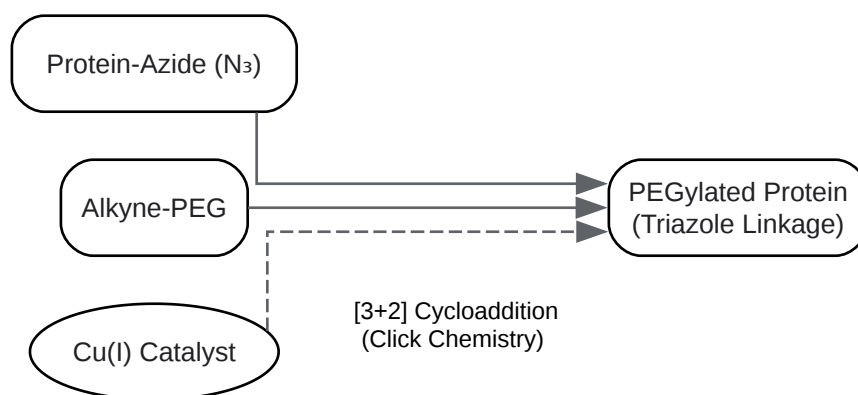

[Click to download full resolution via product page](#)

Caption: Chemistry of unnatural amino acid PEGylation.

Procedure:

- Protein Preparation: Prepare the protein containing the azido-UAA in the reaction buffer.
- Reagent Preparation: Prepare stock solutions of Alkyne-PEG, CuSO₄, sodium ascorbate, and the copper-chelating ligand.
- Reaction Setup: In a reaction vessel, combine the protein solution, Alkyne-PEG (in molar excess), the copper-chelating ligand, and sodium ascorbate.
- Initiate Reaction: Add CuSO₄ to the mixture to initiate the click reaction.
- Incubation: Incubate at room temperature for 1-4 hours.
- Purification: Purify the PEGylated protein using SEC or IEX to remove the catalyst and excess reagents.
- Analysis: Confirm successful conjugation by SDS-PAGE and mass spectrometry.

Conclusion

Site-selective PEGylation is a powerful technique for developing homogeneous and highly active therapeutic proteins. The choice of the appropriate method depends on the specific protein and the desired therapeutic outcome. The protocols and data presented here provide a

guide for researchers to design and execute effective site-selective PEGylation strategies. Careful optimization of reaction conditions and thorough characterization of the final product are critical for success.

Need Custom Synthesis?

BenchChem offers custom synthesis for rare earth carbides and specific isotopic labeling.

Email: info@benchchem.com or [Request Quote Online](#).

References

- [1. benchchem.com \[benchchem.com\]](https://www.benchchem.com)
- [2. europeanpharmaceuticalreview.com \[europeanpharmaceuticalreview.com\]](https://www.europeanpharmaceuticalreview.com)
- [3. peg.bocsci.com \[peg.bocsci.com\]](https://www.peg.bocsci.com)
- [4. researchgate.net \[researchgate.net\]](https://www.researchgate.net)
- [5. pubs.acs.org \[pubs.acs.org\]](https://pubs.acs.org)
- [6. mdpi.com \[mdpi.com\]](https://www.mdpi.com)
- [7. Site-Specific PEGylation of Therapeutic Proteins - PMC \[pmc.ncbi.nlm.nih.gov\]](https://pubmed.ncbi.nlm.nih.gov)
- [8. Frontiers | From Synthesis to Characterization of Site-Selective PEGylated Proteins \[frontiersin.org\]](https://www.frontiersin.org)
- [9. biopharminternational.com \[biopharminternational.com\]](https://www.biopharminternational.com)
- [10. researchgate.net \[researchgate.net\]](https://www.researchgate.net)
- [11. Site-specific PEGylation of proteins containing unnatural amino acids - PubMed \[pubmed.ncbi.nlm.nih.gov\]](https://pubmed.ncbi.nlm.nih.gov)
- [12. researchgate.net \[researchgate.net\]](https://www.researchgate.net)
- [13. creativepegworks.com \[creativepegworks.com\]](https://www.creativepegworks.com)
- [14. Site-Specific PEGylation of Engineered Cysteine Analogs of Recombinant Human Granulocyte-Macrophage Colony-Stimulating Factor - PMC \[pmc.ncbi.nlm.nih.gov\]](https://pubmed.ncbi.nlm.nih.gov)
- [15. ovid.com \[ovid.com\]](https://www.ovid.com)
- [16. youtube.com \[youtube.com\]](https://www.youtube.com)

- [17. Impact of the PEG length and PEGylation site on the structural, thermodynamic, thermal, and proteolytic stability of mono-PEGylated alpha-1 antitrypsin - PMC \[pmc.ncbi.nlm.nih.gov\]](#)
- To cite this document: BenchChem. [Site-Selective Protein Modification with PEG Linkers: Application Notes and Protocols]. BenchChem, [2026]. [Online PDF]. Available at: [<https://www.benchchem.com/product/b15541441/docs#site-selective-protein-modification-with-peg-linkers-application-notes-and-protocols>]

Disclaimer & Data Validity:

The information provided in this document is for Research Use Only (RUO) and is strictly not intended for diagnostic or therapeutic procedures. While BenchChem strives to provide accurate protocols, we make no warranties, express or implied, regarding the fitness of this product for every specific experimental setup.

Technical Support: The protocols provided are for reference purposes. Unsure if this reagent suits your experiment?

Need Industrial/Bulk Grade? [Request Custom Synthesis Quote](#)

BenchChem

Our mission is to be the trusted global source of essential and advanced chemicals, empowering scientists and researchers to drive progress in science and industry.

Contact

Address: 3281 E Guasti Rd
Ontario, CA 91761, United States
Phone: (601) 213-4426
Email: info@benchchem.com

[Contact our Ph.D. Support Team for a compatibility check](#)