

Quantifying Protein Expression with Biotin-PEG-Cy5: Application Notes and Protocols

Author: BenchChem Technical Support Team. **Date:** April 2026

Compound of Interest

Compound Name: *N*-(*m*-PEG4)-*N'*-(biotin-PEG3)-Cy5

Cat. No.: B15541729

[Get Quote](#)

For Researchers, Scientists, and Drug Development Professionals

Introduction

The precise quantification of protein expression is fundamental to understanding cellular processes, identifying disease biomarkers, and developing targeted therapeutics. The use of Biotin-PEG-Cy5 offers a robust and versatile method for labeling and quantifying proteins, particularly those on the cell surface. This molecule combines the high-affinity binding of biotin to streptavidin, the spacing properties of polyethylene glycol (PEG) to reduce steric hindrance, and the bright, far-red fluorescence of Cyanine5 (Cy5) for sensitive detection.

These application notes provide detailed protocols for utilizing Biotin-PEG-Cy5 in various quantitative protein analysis techniques, including flow cytometry and Western blotting. We also present a model application in studying the Epidermal Growth Factor Receptor (EGFR) signaling pathway, a critical pathway in cancer biology.

Principle of the Method

The methodology is based on the covalent labeling of proteins with a Biotin-PEG-Cy5 conjugate. The Cy5 fluorophore allows for direct fluorescent quantification. Alternatively,

proteins can be labeled with a biotin-PEG derivative (e.g., Biotin-PEG-NHS) and subsequently detected with a fluorescently-labeled streptavidin conjugate, such as Streptavidin-Cy5. The N-hydroxysuccinimide (NHS) ester chemistry is commonly employed to react with primary amines on lysine residues and the N-terminus of proteins, forming stable amide bonds.

The choice between direct labeling with Biotin-PEG-Cy5 and indirect detection with Streptavidin-Cy5 depends on the specific application and desired signal amplification. Indirect detection can provide signal amplification as multiple fluorophore-conjugated streptavidin molecules can bind to a single biotinylated protein.

Data Presentation: Quantitative Analysis of Protein Expression

The following tables summarize representative quantitative data obtained from key applications of this technology.

Table 1: Quantification of Cell Surface EGFR Expression on A431 Cells by Flow Cytometry

Cell Line	Treatment	Mean Fluorescence Intensity (MFI) of Cy5	Number of EGFR Molecules per Cell (Approx.)	Reference
A431	Untreated	850,000	~1-3 x 10 ⁶	[1][2]
A431	EGF (100 ng/mL, 30 min)	425,000	~0.5-1.5 x 10 ⁶	[2]
HEK293	Untreated	5,000	Low/Negative	[3]

This table provides an example of how Biotin-PEG-Cy5 can be used to quantify changes in cell surface receptor expression. A431 cells are known to overexpress EGFR.[1][2][3] Upon stimulation with EGF, the receptor is internalized, leading to a decrease in the cell surface population, which is reflected in the reduced Mean Fluorescence Intensity.

Table 2: Quantitative Western Blot Analysis of EGFR Phosphorylation

Cell Line	Treatment	Normalized p-EGFR (Tyr1173) / Total EGFR Ratio	Fold Change vs. Untreated	Reference
A431	Untreated	0.15	1.0	[4][5]
A431	EGF (100 ng/mL, 15 min)	0.85	5.7	[4][5]

This table illustrates the use of fluorescent Western blotting to quantify changes in protein phosphorylation. The ratio of phosphorylated EGFR to total EGFR provides a normalized measure of receptor activation. Fluorescent detection with Cy5-conjugated secondary antibodies offers a wide linear dynamic range for accurate quantification.[5][6]

Table 3: Comparison of Fluorophores for Protein Detection

Fluorophore	Excitation Max (nm)	Emission Max (nm)	Relative Brightness	Photostability	Reference
Cy5	649	671	High	Good	[7][8]
Alexa Fluor 647	650	668	Very High	Excellent	[7][8]
FITC	495	519	Moderate	Poor	

This table provides a comparison of Cy5 with other common fluorophores. Cy5's emission in the far-red spectrum minimizes autofluorescence from cellular components, leading to a better signal-to-noise ratio.[7][8] While Alexa Fluor 647 often exhibits higher brightness and photostability, Cy5 remains a widely used and effective fluorophore for quantitative applications.

Experimental Protocols

Protocol 1: Quantification of Cell Surface Protein Expression by Flow Cytometry

This protocol describes the labeling of cell surface proteins with a biotin-PEG-NHS ester followed by detection with Streptavidin-Cy5 for analysis by flow cytometry.

Materials:

- Cells of interest (e.g., A431 cells)
- Phosphate-Buffered Saline (PBS), ice-cold
- Biotin-PEG-NHS ester (e.g., Sulfo-NHS-LC-Biotin)
- Quenching Buffer (e.g., PBS with 100 mM glycine or 1% BSA)
- Streptavidin-Cy5 conjugate
- FACS Buffer (e.g., PBS with 1% BSA and 0.1% sodium azide)
- Flow cytometer

Procedure:

- **Cell Preparation:** Harvest cells and wash twice with ice-cold PBS by centrifugation (300 x g for 5 minutes at 4°C). Resuspend the cell pellet in ice-cold PBS to a concentration of 1-5 x 10⁶ cells/mL.
- **Biotinylation:** Freshly prepare a solution of Biotin-PEG-NHS ester in PBS at a concentration of 0.1-0.5 mg/mL. Add the biotinylation solution to the cell suspension and incubate for 30 minutes at 4°C with gentle rocking.
- **Quenching:** Pellet the cells by centrifugation and discard the supernatant. Resuspend the cells in ice-cold Quenching Buffer and incubate for 10 minutes at 4°C to stop the reaction.
- **Washing:** Wash the cells three times with ice-cold FACS Buffer.

- **Streptavidin-Cy5 Staining:** Resuspend the cell pellet in FACS Buffer containing the appropriate dilution of Streptavidin-Cy5 (typically 1-5 $\mu\text{g}/\text{mL}$). Incubate for 30 minutes at 4°C in the dark.
- **Final Washes:** Wash the cells twice with FACS Buffer.
- **Flow Cytometry Analysis:** Resuspend the cells in 500 μL of FACS Buffer and analyze on a flow cytometer equipped with a laser and filter set appropriate for Cy5 (e.g., 633 nm or 640 nm excitation and a 660/20 nm bandpass filter).

Protocol 2: Quantitative Western Blotting for Total and Phosphorylated Protein

This protocol outlines the procedure for quantifying total and phosphorylated protein levels using fluorescent secondary antibodies.

Materials:

- Cell lysates
- SDS-PAGE gels and electrophoresis apparatus
- Transfer apparatus and membranes (PVDF or nitrocellulose)
- Blocking Buffer (e.g., 5% BSA or non-fat dry milk in TBST)
- Primary antibodies (specific for the target protein and its phosphorylated form)
- Cy5-conjugated secondary antibody (and a spectrally distinct secondary for the loading control/total protein)
- Wash Buffer (TBST: Tris-Buffered Saline with 0.1% Tween-20)
- Fluorescent imaging system

Procedure:

- **SDS-PAGE and Transfer:** Separate protein lysates by SDS-PAGE and transfer to a PVDF or nitrocellulose membrane according to standard procedures.
- **Blocking:** Block the membrane in Blocking Buffer for 1 hour at room temperature with gentle agitation.
- **Primary Antibody Incubation:** Incubate the membrane with primary antibodies (e.g., rabbit anti-p-EGFR and mouse anti-total EGFR) diluted in Blocking Buffer overnight at 4°C with gentle agitation.
- **Washing:** Wash the membrane three times for 10 minutes each with TBST.
- **Secondary Antibody Incubation:** Incubate the membrane with fluorescently-conjugated secondary antibodies (e.g., anti-rabbit Cy5 and anti-mouse Cy3) diluted in Blocking Buffer for 1 hour at room temperature in the dark.
- **Final Washes:** Wash the membrane three times for 10 minutes each with TBST in the dark.
- **Imaging and Quantification:** Image the membrane using a fluorescent imaging system with the appropriate laser and filter settings for Cy5 and any other fluorophores used. Quantify the band intensities using appropriate software. Normalize the signal of the phosphorylated protein to the total protein signal.

Mandatory Visualizations

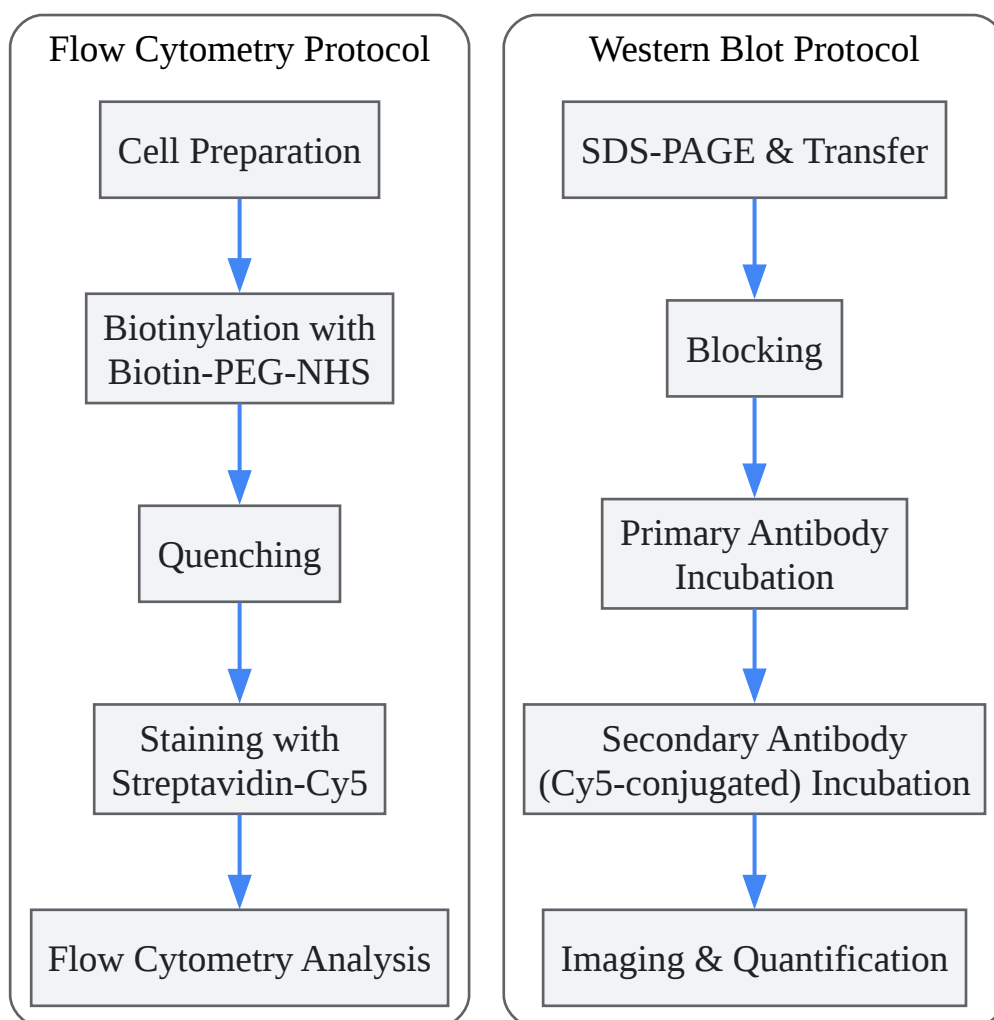

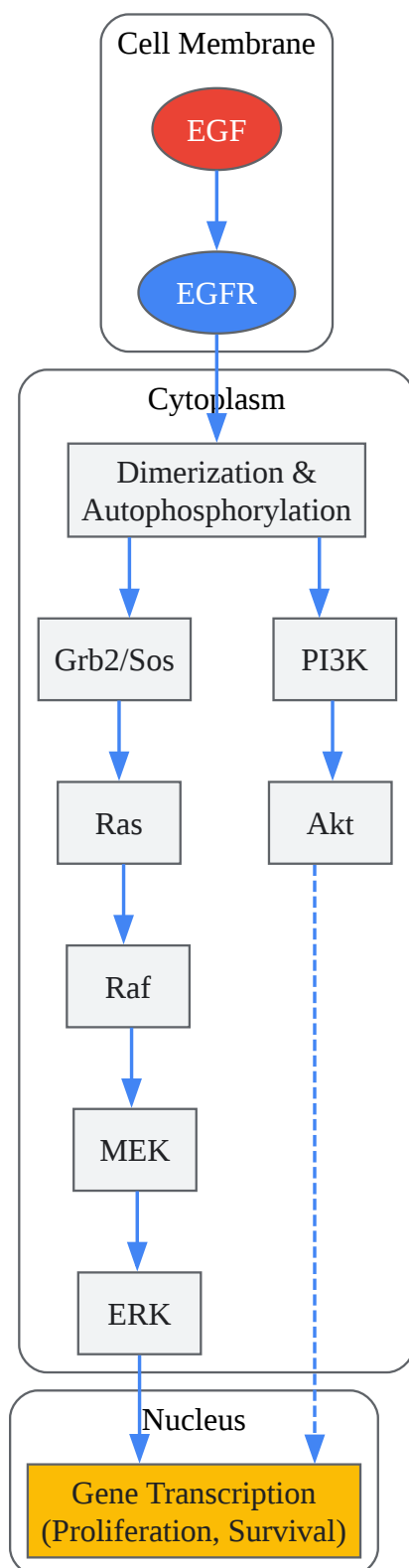

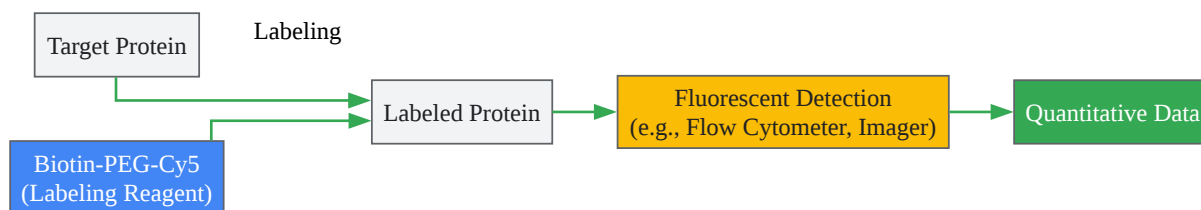

[Click to download full resolution via product page](#)

Need Custom Synthesis?

BenchChem offers custom synthesis for rare earth carbides and specific isotopic labeling.

Email: info@benchchem.com or [Request Quote Online](#).

References

- [1. researchgate.net \[researchgate.net\]](#)
- [2. aacrjournals.org \[aacrjournals.org\]](#)
- [3. researchgate.net \[researchgate.net\]](#)
- [4. Analyzing expression and phosphorylation of the EGF receptor in HNSCC - PMC \[pmc.ncbi.nlm.nih.gov\]](#)
- [5. researchgate.net \[researchgate.net\]](#)
- [6. Fluorescent Western blotting \[jacksonimmuno.com\]](#)
- [7. researchgate.net \[researchgate.net\]](#)
- [8. Quantitative comparison of long-wavelength Alexa Fluor dyes to Cy dyes: fluorescence of the dyes and their bioconjugates - PubMed \[pubmed.ncbi.nlm.nih.gov\]](#)
- To cite this document: BenchChem. [Quantifying Protein Expression with Biotin-PEG-Cy5: Application Notes and Protocols]. BenchChem, [2026]. [Online PDF]. Available at: [\[https://www.benchchem.com/product/b15541729/docs#quantifying-protein-expression-with-biotin-peg-cy5-application-notes-and-protocols\]](https://www.benchchem.com/product/b15541729/docs#quantifying-protein-expression-with-biotin-peg-cy5-application-notes-and-protocols)

Disclaimer & Data Validity:

The information provided in this document is for Research Use Only (RUO) and is strictly not intended for diagnostic or therapeutic procedures. While BenchChem strives to provide accurate protocols, we make no warranties, express or implied, regarding the fitness of this product for every specific experimental setup.

Technical Support: The protocols provided are for reference purposes. Unsure if this reagent suits your experiment?

Need Industrial/Bulk Grade? [Request Custom Synthesis Quote](#)

BenchChem

Our mission is to be the trusted global source of essential and advanced chemicals, empowering scientists and researchers to drive progress in science and industry.

Contact

Address: 3281 E Guasti Rd
Ontario, CA 91761, United States
Phone: (601) 213-4426
Email: info@benchchem.com

[Contact our Ph.D. Support Team for a compatibility check](#)