

# Optimizing stimulation conditions for primary T-cell experiments

**Author:** BenchChem Technical Support Team. **Date:** April 2026

## Compound of Interest

Compound Name: *ITK ligand 1*

Cat. No.: *B15541571*

[Get Quote](#)

## Technical Support Center: Optimizing Primary T-Cell Experiments

Welcome to the technical support center for primary T-cell experiments. This resource provides troubleshooting guides and frequently asked questions (FAQs) to help researchers, scientists, and drug development professionals optimize their T-cell stimulation conditions and overcome common experimental hurdles.

## Frequently Asked Questions (FAQs) & Troubleshooting

### General T-Cell Culture & Stimulation

**Q1:** My primary T-cells show poor activation and proliferation after stimulation. What are the potential causes and solutions?

**A1:** Poor T-cell activation is a common issue with several potential causes. Here's a breakdown of factors to investigate:

- Suboptimal Cell Density: T-cell activation is highly dependent on cell density. Low cell densities can lead to insufficient cell-to-cell contact and autocrine/paracrine signaling, resulting in activation failure and apoptosis. Conversely, excessive density can lead to rapid nutrient depletion and accumulation of toxic byproducts.[1][2]
  - Recommendation: Maintain a cell density of at least  $1 \times 10^6$  cells/mL during the initial activation phase.[3] For expansion, aim for a density of  $3-5 \times 10^6$  cells/mL.[3]
- Inadequate Stimulation Signal: The strength and nature of the activation signal are critical.
  - Recommendation: Ensure proper concentration and coating of anti-CD3 and anti-CD28 antibodies if using plate-bound methods.[4][5] For bead-based methods, use the recommended bead-to-cell ratio, as excess beads can inhibit expansion.[6]
- Poor Quality of Starting Cells: The health and purity of the isolated T-cells are paramount.
  - Recommendation: Ensure high viability (>95%) of peripheral blood mononuclear cells (PBMCs) or isolated T-cells before starting the experiment. Use appropriate T-cell isolation kits and handle cells gently during the procedure.[4][5]
- Media and Supplement Issues: The culture medium and supplements play a vital role in T-cell survival and proliferation.[7]
  - Recommendation: Use a high-quality, complete RPMI 1640 medium supplemented with fetal bovine serum (FBS) or human serum, L-glutamine, and antibiotics.[7][8] The addition of cytokines like IL-2 is crucial for T-cell expansion after activation.[7]

Q2: I'm observing high variability between my experimental replicates. How can I improve consistency?

A2: Inter-experimental variability is a frequent challenge in primary cell culture. Here are some strategies to minimize it:

- Standardize Protocols: Ensure all experimental steps, from cell isolation to data analysis, are performed consistently across all replicates and experiments.[9]

- **Consistent Cell Handling:** Gentle and consistent handling of cells is crucial to avoid stress and damage. This includes centrifugation speeds and resuspension techniques.
- **Donor Variability:** Primary T-cells from different donors can exhibit significant functional differences.
  - **Recommendation:** If possible, use cells from the same donor for a set of comparative experiments. When using multiple donors, be prepared for inherent biological variation and consider it in your data analysis.[\[10\]](#)
- **Reagent Quality:** Use high-quality, validated reagents and avoid repeated freeze-thaw cycles of cytokines and antibodies.
- **Automated Cell Counting:** Utilize automated cell counters for accurate and consistent cell density measurements.
- **Control for Edge Effects:** In plate-based assays, the outer wells are more prone to evaporation, which can affect cell growth.
  - **Recommendation:** Avoid using the outermost wells of the culture plate for critical experimental samples. Instead, fill them with sterile PBS or media to maintain humidity.[\[11\]](#)

## Stimulation Methods

Q3: What are the main differences between bead-based and plate-bound T-cell stimulation methods?

A3: Both methods are effective for polyclonal T-cell activation but have distinct advantages and disadvantages.

- **Bead-Based Stimulation:** Utilizes magnetic beads coated with anti-CD3 and anti-CD28 antibodies.[\[12\]](#)
  - **Advantages:** Provides uniform and consistent stimulation, is highly scalable, and allows for easy removal of the stimulation signal.[\[13\]](#) Bead-based methods often result in robust expansion of CD8+ T-cells.[\[12\]](#)
  - **Disadvantages:** Can be more expensive than plate-bound methods.

- Plate-Bound Stimulation: Involves coating culture plates with anti-CD3 antibodies, with anti-CD28 antibodies typically added in a soluble form.[4][12]
  - Advantages: Cost-effective and straightforward to set up. This method is known to be effective for the expansion of CD4+ T-cells.[12]
  - Disadvantages: Can lead to less uniform stimulation compared to beads, as the antibodies are immobilized on a 2D surface. The stimulation signal is persistent and cannot be easily removed.[14]

## Cytokines & Cell Health

Q4: Which cytokines should I use for optimal T-cell expansion, and at what concentrations?

A4: The choice of cytokines depends on the desired T-cell subset and the experimental goals.

- IL-2: The most common cytokine for promoting general T-cell proliferation. A typical concentration is 20-100 IU/mL.[15] However, high concentrations of IL-2 can favor the differentiation of effector T-cells and may not be ideal for generating long-lived memory T-cells.[16]
- IL-7 and IL-15: These cytokines are known to promote the survival and expansion of memory T-cell populations.[7][16] A combination of IL-7 and IL-15 is often used to generate less differentiated, more persistent T-cells.[17]
- IL-4: Can promote the expansion of CD4+ T-cells.[17]
- IL-21: Can enhance the activity of CD8+ T-cells and promote the formation of central memory T-cells.[18]

Q5: My T-cells appear exhausted after a period of culture. How can I prevent or mitigate this?

A5: T-cell exhaustion is characterized by a progressive loss of effector function and proliferative capacity due to chronic stimulation.

- Rest Periods: Avoid continuous, high-level stimulation. Allowing T-cells to rest between stimulation cycles can help maintain their functionality. A rest period of 8-10 days after initial activation is recommended before restimulation.[19]

- **Optimal Stimulation Strength:** Use the lowest effective concentration of stimulating antibodies or beads to avoid overstimulation.
- **Cytokine Choice:** As mentioned, using cytokines like IL-7 and IL-15 can promote the development of more robust memory T-cell populations that are less prone to exhaustion.
- **Inhibitory Receptor Blockade:** In some contexts, blocking inhibitory receptors like PD-1 can help reverse or prevent T-cell exhaustion.

## Data & Protocols

### Comparative Data Tables

Table 1: Comparison of T-Cell Stimulation Methods

Feature	Bead-Based Stimulation (e.g., Dynabeads™)	Plate-Bound Stimulation	Soluble Antibody Stimulation
Principle	Antibodies coated on magnetic beads mimic APCs.	Anti-CD3 antibody immobilized on a culture plate surface.	Antibodies are free in the culture medium.
Signal Uniformity	High	Moderate to Low	Low, depends on cross-linking
Signal Removal	Yes (magnetic removal)	No	No
Scalability	High	Moderate	Moderate
Cost	Higher	Lower	Variable
Primary Cell Type Expanded	Effective for both CD4+ and CD8+, often yields more terminally differentiated CD8+ cells.[12][20]	Particularly effective for CD4+ T-cells.[12]	Can yield less differentiated CD4+ and CD8+ cells.[12]
Reference	[13][15][21]	[4][12][14]	[12]

Table 2: Recommended Cytokine Cocktails for T-Cell Expansion

Cytokine Cocktail	Primary Effect	Predominant T-Cell Subset Favored	Typical Concentration Range	Reference
IL-2	General proliferation and effector differentiation.	Effector T-cells	20-300 IU/mL	[7][15][22]
IL-7 + IL-15	Promotes survival and expansion of less differentiated, long-lived memory cells.	Central Memory & Stem Cell Memory T-cells	IL-7: 5-10 ng/mL, IL-15: 5-10 ng/mL	[16][17]
IL-4 + IL-7	Promotes CD4+ T-cell expansion.	CD4+ Helper T-cells	IL-4: 5-10 ng/mL, IL-7: 5-10 ng/mL	[17]
IL-12 + IL-7/IL-21	Regulates the differentiation of anti-tumor CD8+ T-cells.	Effector and Memory CD8+ T-cells	IL-12: 10 ng/mL, IL-7/IL-21: 10 ng/mL	[16]

## Experimental Protocols

### Protocol 1: Isolation of Primary Human T-Cells from PBMCs

This protocol describes the isolation of T-cells from Peripheral Blood Mononuclear Cells (PBMCs) using negative selection.

- **PBMC Preparation:** Isolate PBMCs from whole blood or a buffy coat using density gradient centrifugation (e.g., Ficoll-Paque).
- **Cell Counting and Resuspension:** Wash the isolated PBMCs twice with PBS containing 2% FBS. Resuspend the cells in the appropriate buffer and perform a cell count to determine the total number of viable cells.

- **Negative Selection:** a. Resuspend the PBMC pellet in the recommended buffer provided with your T-cell isolation kit. b. Add the antibody cocktail for negative selection, which targets non-T-cells (e.g., B cells, NK cells, monocytes). Incubate as per the manufacturer's instructions. c. Add magnetic particles that will bind to the antibody-labeled cells. d. Place the tube in a magnetic separator. The unlabeled, "untouched" T-cells will remain in suspension. e. Carefully collect the supernatant containing the enriched T-cells.
- **Purity Assessment:** Assess the purity of the isolated T-cell population using flow cytometry by staining for CD3.

#### Protocol 2: T-Cell Activation and Expansion using anti-CD3/CD28 Beads

- **Cell Seeding:** Resuspend the purified T-cells in complete RPMI medium supplemented with appropriate cytokines (e.g., IL-2) at a density of  $1 \times 10^6$  cells/mL.
- **Bead Preparation:** Wash the anti-CD3/CD28 magnetic beads according to the manufacturer's protocol to remove any preservatives.
- **Stimulation:** Add the washed beads to the T-cell culture at the recommended bead-to-cell ratio (typically 1:1).
- **Incubation:** Culture the cells at 37°C in a humidified CO2 incubator.
- **Expansion and Monitoring:** a. Monitor cell growth and morphology daily. Activated T-cells will form clusters around the beads and increase in size (blastogenesis). b. After 2-3 days, dilute the culture with fresh medium containing cytokines to maintain an optimal cell density for expansion (e.g.,  $0.5-2 \times 10^6$  cells/mL). This may involve splitting the cells into new culture vessels. c. Continue to monitor and split the cells as needed for the desired duration of the experiment (typically 10-14 days for significant expansion).<sup>[7]</sup>
- **Bead Removal:** Before downstream applications, remove the magnetic beads by placing the culture vessel on a magnet and carefully transferring the cell suspension.

#### Protocol 3: Assessment of T-Cell Proliferation using CFSE Staining

Carboxyfluorescein succinimidyl ester (CFSE) is a fluorescent dye that allows for the tracking of cell division.

- CFSE Labeling: a. Resuspend T-cells in pre-warmed PBS at a concentration of  $1-10 \times 10^6$  cells/mL. b. Add CFSE to a final concentration of 1-5  $\mu\text{M}$ . Mix immediately by gentle vortexing. c. Incubate for 10-15 minutes at  $37^\circ\text{C}$ , protected from light. d. Quench the staining reaction by adding 5 volumes of cold complete medium. e. Wash the cells twice with complete medium to remove any unbound dye.
- Cell Culture and Stimulation: Culture the CFSE-labeled T-cells under your desired stimulation conditions.
- Flow Cytometry Analysis: a. At various time points after stimulation (e.g., day 3, 5, 7), harvest the cells. b. Analyze the cells by flow cytometry. With each cell division, the CFSE fluorescence intensity will be halved, allowing for the visualization of distinct peaks corresponding to each generation of divided cells.[\[23\]](#)

## Diagrams

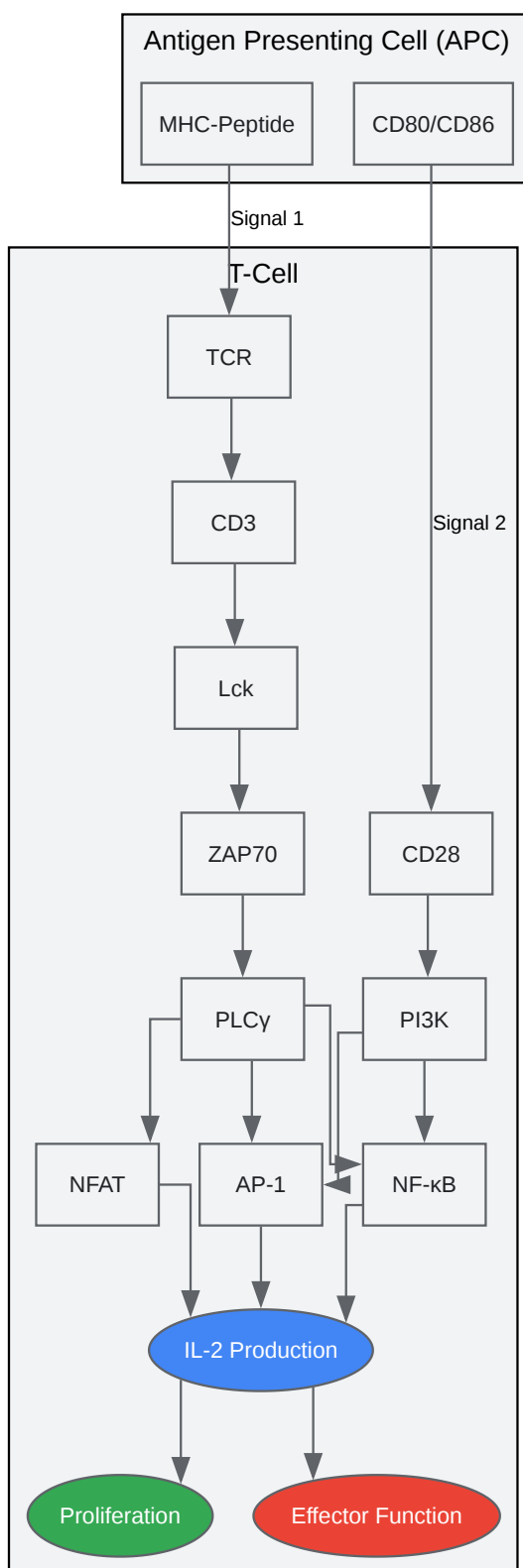

[Click to download full resolution via product page](#)

T-Cell Activation Signaling Pathway

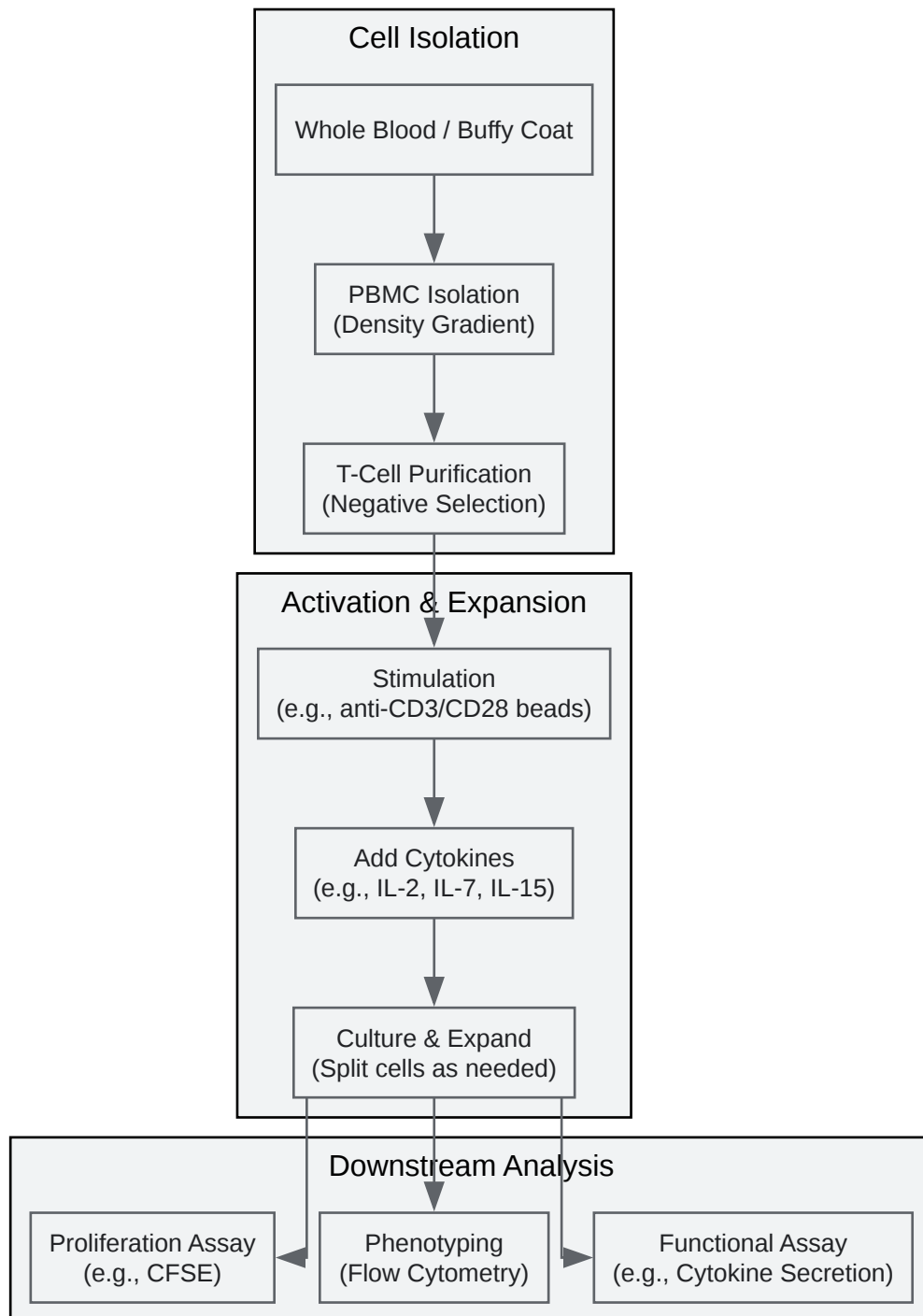

[Click to download full resolution via product page](#)

### General T-Cell Experimental Workflow

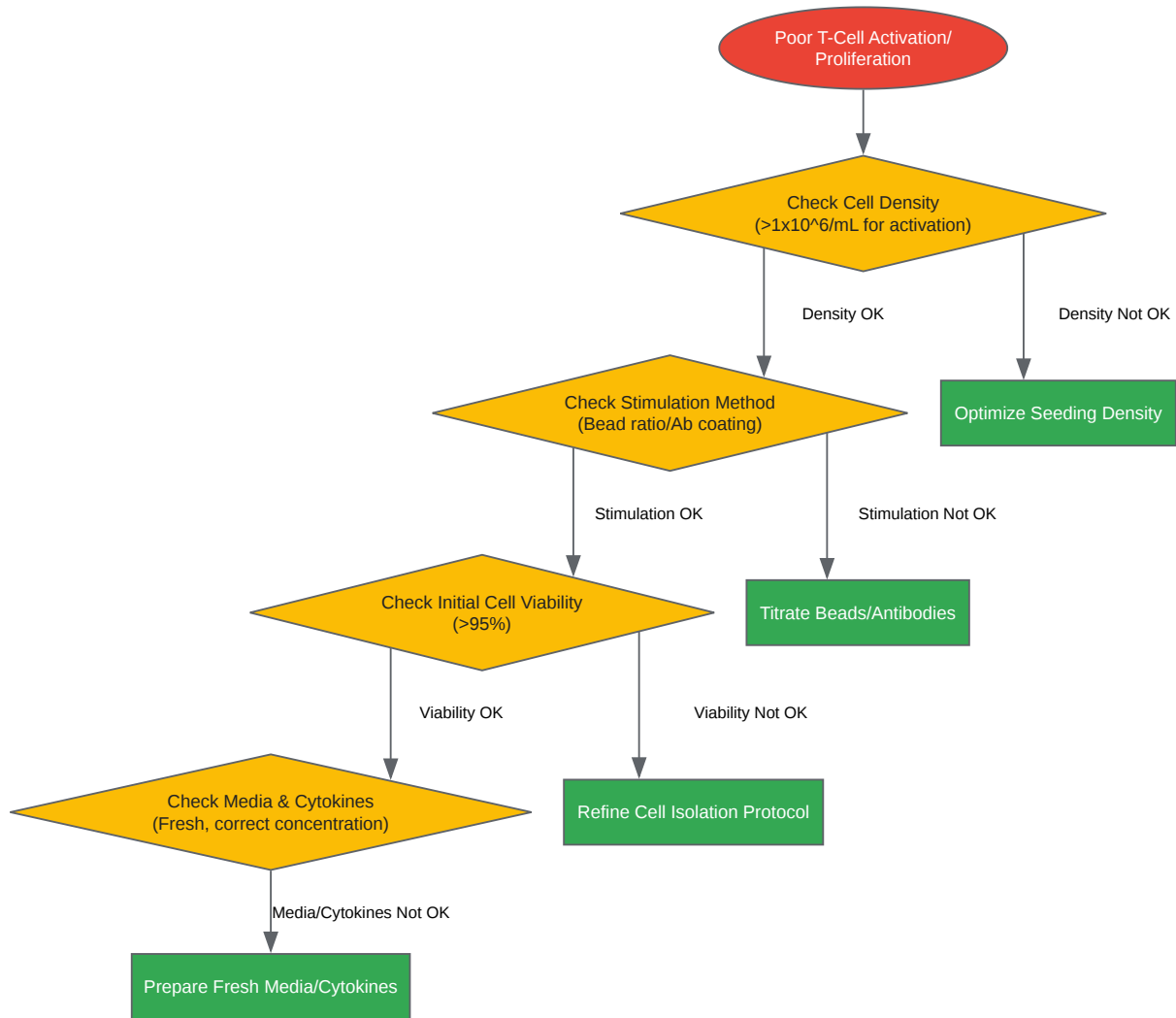

[Click to download full resolution via product page](#)

### Need Custom Synthesis?

BenchChem offers custom synthesis for rare earth carbides and specific isotopic labeling.

Email: [info@benchchem.com](mailto:info@benchchem.com) or [Request Quote Online](#).

## References

- 1. Cell Density Plays a Critical Role in Ex Vivo Expansion of T Cells for Adoptive Immunotherapy - PMC [[pmc.ncbi.nlm.nih.gov](https://pubmed.ncbi.nlm.nih.gov/pmc/)]
- 2. Cell density plays a critical role in ex vivo expansion of T cells for adoptive immunotherapy - PubMed [[pubmed.ncbi.nlm.nih.gov](https://pubmed.ncbi.nlm.nih.gov/)]
- 3. [researchgate.net](https://www.researchgate.net/) [[researchgate.net](https://www.researchgate.net/)]
- 4. T cell purification and activation [[protocols.io](https://www.protocols.io/)]
- 5. [researchgate.net](https://www.researchgate.net/) [[researchgate.net](https://www.researchgate.net/)]
- 6. Physiological Activation of Human T Cells | Thermo Fisher Scientific - JP [[thermofisher.com](https://www.thermofisher.com/)]
- 7. [akadeum.com](https://www.akadeum.com/) [[akadeum.com](https://www.akadeum.com/)]
- 8. [biocompare.com](https://www.biocompare.com/) [[biocompare.com](https://www.biocompare.com/)]
- 9. [promegaconnections.com](https://www.promegaconnections.com/) [[promegaconnections.com](https://www.promegaconnections.com/)]
- 10. [m.youtube.com](https://www.youtube.com/) [[m.youtube.com](https://www.youtube.com/)]
- 11. [benchchem.com](https://www.benchchem.com/) [[benchchem.com](https://www.benchchem.com/)]
- 12. [akadeum.com](https://www.akadeum.com/) [[akadeum.com](https://www.akadeum.com/)]
- 13. Optimizing T Cell Activation with CD3/CD28 Magnetic Beads: A Comprehensive Guide - nanomicronspheres [[nanomicronspheres.com](https://www.nanomicronspheres.com/)]
- 14. [researchgate.net](https://www.researchgate.net/) [[researchgate.net](https://www.researchgate.net/)]
- 15. [peerj.com](https://www.peerj.com/) [[peerj.com](https://www.peerj.com/)]
- 16. [researchgate.net](https://www.researchgate.net/) [[researchgate.net](https://www.researchgate.net/)]
- 17. Transcriptomic analysis reveals optimal cytokine combinations for SARS-CoV-2-specific T cell therapy products - PMC [[pmc.ncbi.nlm.nih.gov](https://pubmed.ncbi.nlm.nih.gov/pmc/)]
- 18. WO2022056285A1 - Cytokine cocktails for selective expansion of t cell subsets - Google Patents [[patents.google.com](https://patents.google.com/)]

- [19. Optimizing T Cell Functionality : Tips to Prevent Exhaustion \[allegrowbiotech.com\]](#)
- [20. Comparison of anti-CD3 and anti-CD28-coated beads with soluble anti-CD3 for expanding human T cells: Differing impact on CD8 T cell phenotype and responsiveness to restimulation - PMC \[pmc.ncbi.nlm.nih.gov\]](#)
- [21. A comparison between cytokine- and bead-stimulated polyclonal T cells: the superiority of each and their possible complementary role - PMC \[pmc.ncbi.nlm.nih.gov\]](#)
- [22. researchgate.net \[researchgate.net\]](#)
- [23. reactionbiology.com \[reactionbiology.com\]](#)
- To cite this document: BenchChem. [Optimizing stimulation conditions for primary T-cell experiments]. BenchChem, [2026]. [Online PDF]. Available at: [\[https://www.benchchem.com/product/b15541571/docs#optimizing-stimulation-conditions-for-primary-t-cell-experiments\]](https://www.benchchem.com/product/b15541571/docs#optimizing-stimulation-conditions-for-primary-t-cell-experiments)

---

#### Disclaimer & Data Validity:

The information provided in this document is for Research Use Only (RUO) and is strictly not intended for diagnostic or therapeutic procedures. While BenchChem strives to provide accurate protocols, we make no warranties, express or implied, regarding the fitness of this product for every specific experimental setup.

**Technical Support:** The protocols provided are for reference purposes. Unsure if this reagent suits your experiment?

**Need Industrial/Bulk Grade?** [Request Custom Synthesis Quote](#)

## BenchChem

Our mission is to be the trusted global source of essential and advanced chemicals, empowering scientists and researchers to drive progress in science and industry.

#### Contact

Address: 3281 E Guasti Rd  
Ontario, CA 91761, United States  
Phone: (601) 213-4426  
Email: [info@benchchem.com](mailto:info@benchchem.com)

Contact our Ph.D. Support Team for a compatibility check