

JNJ-7706204 effect on cell cycle progression

Author: BenchChem Technical Support Team. **Date:** May 2026

Compound of Interest

Compound Name: JNJ-6204
Cat. No.: B15541541

[Get Quote](#)

An In-Depth Technical Guide on the Effect of JNJ-7706621 on Cell Cycle Progression

For Researchers, Scientists, and Drug Development Professionals

Abstract

JNJ-7706621 is a potent, small molecule inhibitor targeting both cyclin-dependent kinases (CDKs) and Aurora kinases, key regulators of cell cycle progression.[1][2] This dual inhibitory action leads to a multifaceted disruption of the cell cycle in cancer cells, ultimately inducing growth arrest and apoptosis.[1][2] Preclinical studies have demonstrated its efficacy in various tumor cell lines, highlighting its potential as a therapeutic agent.[1][3] This technical guide provides a comprehensive overview of the effects of JNJ-7706621 on cell cycle progression, including its mechanism of action, quantitative effects on cell cycle phases, and detailed experimental protocols for its evaluation.

Mechanism of Action: Dual Inhibition of CDKs and Aurora Kinases

JNJ-7706621 exerts its effects on the cell cycle through the simultaneous inhibition of two critical families of serine/threonine kinases: cyclin-dependent kinases (CDKs) and Aurora kinases.[1][2]

- Cyclin-Dependent Kinases (CDKs): CDKs are fundamental for the orderly progression through the different phases of the cell cycle. JNJ-7706621 has been shown to inhibit CDK1 and CDK2. Inhibition of these CDKs disrupts the transitions between cell cycle phases, particularly the G1/S and G2/M checkpoints.[1][2]
- Aurora Kinases: Aurora kinases (A, B, and C) play a crucial role during mitosis, governing processes such as centrosome maturation, spindle assembly, chromosome segregation, and cytokinesis.[4] By inhibiting Aurora kinases, JNJ-7706621 disrupts the proper execution of mitosis, leading to endoreduplication (the replication of the genome without cell division) and apoptosis.[1][3]

The synergistic inhibition of both CDKs and Aurora kinases results in a robust anti-proliferative effect on cancer cells.

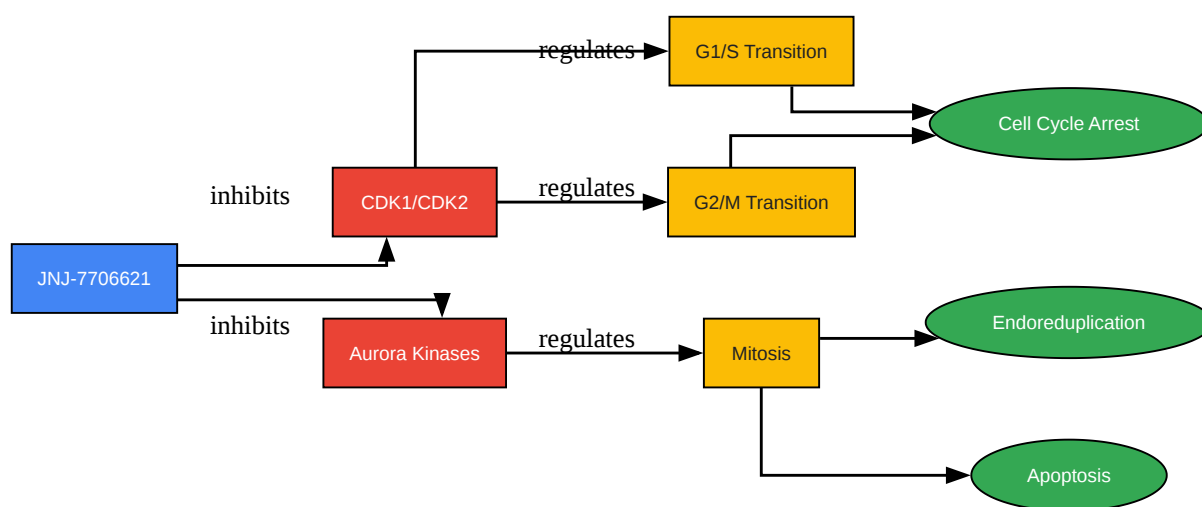

[Click to download full resolution via product page](#)

Figure 1: Simplified signaling pathway of JNJ-7706621's mechanism of action.

Quantitative Effects on Cell Cycle Progression

Treatment of cancer cells with JNJ-7706621 leads to distinct and quantifiable changes in the distribution of cells across the different phases of the cell cycle.

Cell Cycle Arrest Profile

Flow cytometric analysis of DNA content reveals that JNJ-7706621 induces a delay in G1 progression and a significant arrest of cells in the G2/M phase.[1][2] At higher concentrations and longer exposure times, a population of cells with a DNA content greater than 4N emerges, indicative of endoreduplication.

Cell Line	Concentration (µmol/L)	Time (hours)	Predominant Effect	Reference
HeLa	3	16	Delayed entry into S phase	
HeLa	2	24	G2/M arrest	
HeLa	3	24-72	Sustained G2/M arrest	
HeLa	2	72	Emergence of 8N population (endoreduplication)	

Inhibition of Histone H3 Phosphorylation

A key downstream effect of Aurora kinase B inhibition is the reduction of histone H3 phosphorylation on Serine 10, a critical event for chromosome condensation and segregation during mitosis. JNJ-7706621 treatment leads to a dose-dependent decrease in phosphorylated histone H3 levels.[1]

Detailed Experimental Protocols

The following are detailed methodologies for key experiments used to characterize the effects of JNJ-7706621 on the cell cycle.

Cell Cycle Analysis by Flow Cytometry

This protocol allows for the quantification of cells in different phases of the cell cycle based on their DNA content.

Materials:

- Cancer cell line of interest (e.g., HeLa)
- JNJ-7706621
- Phosphate-buffered saline (PBS)
- 70% ice-cold ethanol
- RNase A (100 µg/mL)
- Propidium Iodide (PI) staining solution (50 µg/mL)
- Flow cytometer

Procedure:

- **Cell Treatment:** Seed cells at an appropriate density and allow them to adhere overnight. Treat the cells with various concentrations of JNJ-7706621 or vehicle control for the desired time points.
- **Cell Harvesting:** Harvest the cells by trypsinization and collect them by centrifugation.
- **Fixation:** Wash the cell pellet with PBS and then resuspend in ice-cold 70% ethanol while vortexing gently to prevent clumping. Fix the cells for at least 30 minutes at 4°C.[5]
- **Staining:** Centrifuge the fixed cells and wash twice with PBS. Resuspend the cell pellet in a solution containing RNase A and incubate for 15-30 minutes at 37°C to degrade RNA.[5] Add PI staining solution and incubate for at least 15 minutes in the dark.[5]
- **Flow Cytometry:** Analyze the stained cells using a flow cytometer, collecting at least 10,000-20,000 events per sample. The PI fluorescence intensity is proportional to the DNA content.
- **Data Analysis:** Use cell cycle analysis software (e.g., FlowJo, ModFit) to deconvolute the DNA content histograms and determine the percentage of cells in the G1, S, and G2/M phases of the cell cycle.[5]

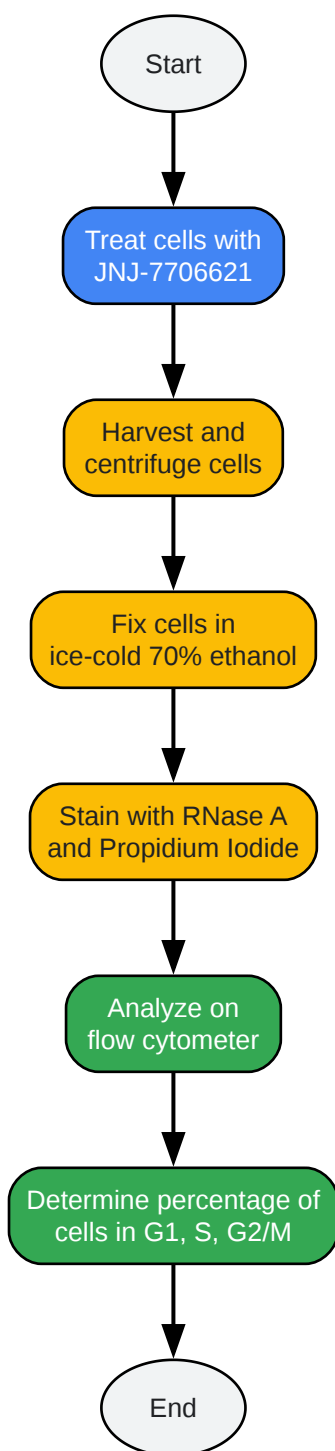

[Click to download full resolution via product page](#)

Figure 2: Experimental workflow for cell cycle analysis using flow cytometry.

Western Blotting for Phospho-Histone H3

This protocol is used to detect the levels of phosphorylated histone H3 as a marker of Aurora kinase B activity.

Materials:

- Treated cell lysates
- SDS-PAGE gels
- Transfer apparatus and membranes (e.g., PVDF)
- Blocking buffer (e.g., 5% non-fat milk or BSA in TBST)
- Primary antibodies: anti-phospho-histone H3 (Ser10) and a loading control (e.g., anti- β -actin or anti-GAPDH)
- HRP-conjugated secondary antibody
- Chemiluminescent substrate
- Imaging system

Procedure:

- Protein Extraction: Lyse the treated cells in a suitable lysis buffer containing protease and phosphatase inhibitors. Determine the protein concentration of the lysates.
- SDS-PAGE: Separate equal amounts of protein from each sample by sodium dodecyl sulfate-polyacrylamide gel electrophoresis (SDS-PAGE).
- Protein Transfer: Transfer the separated proteins from the gel to a PVDF membrane.
- Blocking: Block the membrane with a suitable blocking buffer for at least 1 hour at room temperature to prevent non-specific antibody binding.
- Primary Antibody Incubation: Incubate the membrane with the primary antibody against phospho-histone H3 (Ser10) overnight at 4°C.

- Secondary Antibody Incubation: Wash the membrane and incubate with the appropriate HRP-conjugated secondary antibody for 1 hour at room temperature.
- Detection: After further washing, add the chemiluminescent substrate and detect the signal using an imaging system.
- Stripping and Re-probing: The membrane can be stripped and re-probed with an antibody for a loading control to ensure equal protein loading.

Conclusion

JNJ-7706621 is a dual inhibitor of CDKs and Aurora kinases that potently disrupts cell cycle progression in cancer cells. Its mechanism of action leads to a G2/M phase arrest and the induction of endoreduplication and apoptosis. The experimental protocols detailed in this guide provide a framework for the robust evaluation of JNJ-7706621 and other compounds with similar mechanisms of action. The quantitative data and methodologies presented here are essential for researchers and drug development professionals working on novel anti-cancer therapeutics targeting the cell cycle.

Need Custom Synthesis?

BenchChem offers custom synthesis for rare earth carbides and specific isotopic labeling.

Email: info@benchchem.com or [Request Quote Online](#).

References

- [1. The in vitro and in vivo effects of JNJ-7706621: a dual inhibitor of cyclin-dependent kinases and aurora kinases - PubMed \[pubmed.ncbi.nlm.nih.gov\]](#)
- [2. researchgate.net \[researchgate.net\]](#)
- [3. Preclinical characterization of Aurora kinase inhibitor R763/AS703569 identified through an image-based phenotypic screen - PubMed \[pubmed.ncbi.nlm.nih.gov\]](#)
- [4. Aurora kinase inhibitors in preclinical and clinical testing - PubMed \[pubmed.ncbi.nlm.nih.gov\]](#)
- [5. icms.qmul.ac.uk \[icms.qmul.ac.uk\]](#)

- To cite this document: BenchChem. [JNJ-7706204 effect on cell cycle progression]. BenchChem, [2026]. [Online PDF]. Available at: [<https://www.benchchem.com/product/b15541541/docs#jnj-7706204-effect-on-cell-cycle-progression>]

Disclaimer & Data Validity:

The information provided in this document is for Research Use Only (RUO) and is strictly not intended for diagnostic or therapeutic procedures. While BenchChem strives to provide accurate protocols, we make no warranties, express or implied, regarding the fitness of this product for every specific experimental setup.

Technical Support: The protocols provided are for reference purposes. Unsure if this reagent suits your experiment?

Need Industrial/Bulk Grade? [Request Custom Synthesis Quote](#)

BenchChem

Our mission is to be the trusted global source of essential and advanced chemicals, empowering scientists and researchers to drive progress in science and industry.

Contact

Address: 3281 E Guasti Rd
Ontario, CA 91761, United States
Phone: (601) 213-4426
Email: info@benchchem.com

[Contact our Ph.D. Support Team for a compatibility check](#)