

## Interpreting complex data from ITK signaling studies

Author: BenchChem Technical Support Team. Date: April 2026

### Compound of Interest

Compound Name: *ITK ligand 1*

Cat. No.: *B15541571*

[Get Quote](#)

## ITK Signaling Studies Technical Support Center

Welcome to the technical support center for researchers, scientists, and drug development professionals working with Interleukin-2-inducible T-cell Kinase (ITK) signaling. This resource provides troubleshooting guides and frequently asked questions (FAQs) to assist you in interpreting complex data from experiments.

### Frequently Asked Questions (FAQs)

Q1: What is the primary function of ITK in T-cell signaling?

A1: ITK, or Interleukin-2-inducible T-cell kinase, is a crucial non-receptor tyrosine kinase in T-cells.<sup>[1][2]</sup> It acts as a key component of the T-cell receptor signaling pathway, primarily functioning to amplify the signals initiated by TCR engagement.<sup>[1]</sup> Upon TCR activation, ITK is itself activated and proceeds to phosphorylate and activate Phospholipase C gamma 1 (PLCγ1).<sup>[3][4]</sup> This activation leads to a cascade of downstream events, including calcium mobilization and the activation of transcription factors like NFAT and NF-κB, which are essential for T-cell activation, proliferation, and differentiation.<sup>[1][3]</sup>

Q2: My Western blot for phosphorylated ITK (p-ITK) shows no signal. What are the possible reasons?

A2: Several factors could lead to a lack of signal for phosphorylated ITK. First, ensure that your cells were properly stimulated to induce ITK phosphorylation, as the modification can be transient.<sup>[5]</sup> The timing of cell lysis after stimulation is critical. Additionally, phosphatases released during cell lysis can dephosphorylate your target protein; therefore, it is essential to use pre-chilled buffers and include phosphatase inhibitors in your lysis buffer. Other potential issues include low protein expression in your cell or tissue type, insufficient protein loading on the gel, or the use of an inappropriate primary or secondary antibody.<sup>[6]</sup> It is also recommended to avoid using milk as a blocking agent, as it contains casein, a phosphoprotein that can increase background noise.

Q3: I am observing conflicting results between my ITK knockout/knockdown experiments and those using a small molecule inhibitor. Why might this be?

A3: Discrepancies between genetic knockout/knockdown models and pharmacological inhibition are not uncommon in ITK signaling studies. ITK is known to have both kinase-dependent and kinase-independent (scaffolding) functions.<sup>[7]</sup> A knockout or knockdown approach ablates the entire protein, affecting all functions. In contrast, a small molecule inhibitor typically targets the kinase activity specifically. Therefore, if the observed phenotype is related to ITK's scaffolding role, a kinase inhibitor may not replicate the results seen in a knockout model.<sup>[7]</sup> Furthermore, genetic models can sometimes lead to developmental compensation by other related kinases, such as RLK (Resting Lymphocyte Kinase).<sup>[1]</sup>

Q4: How can I best quantify ITK kinase activity in my samples?

A4: An in vitro kinase assay is a direct method to quantify ITK's enzymatic activity. This assay typically involves incubating recombinant ITK with a specific substrate and radiolabeled ATP (e.g., γ-<sup>32</sup>P-ATP). The amount of radioactivity transferred to the substrate is then measured and is proportional to the activity. Alternatively, non-radioactive, luminescence-based assays such as the ADP-Glo™ Kinase Assay are available.<sup>[2][8]</sup> These assays measure the amount of ADP produced during the kinase reaction, which correlates with kinase activity.<sup>[2]</sup> When performing these assays, it is crucial to optimize enzyme and substrate concentrations and to include appropriate controls, such as a no-enzyme control and a known inhibitor control.<sup>[8]</sup>

Q5: What are the key downstream readouts to measure ITK activation using flow cytometry?

A5: Flow cytometry is a powerful tool for analyzing ITK signaling at the single-cell level. Key downstream events that can be measured to infer ITK activation include the phosphorylation of its direct substrate, PLC $\gamma$ 1.[9] You can also assess more distal signaling events, such as the phosphorylation of ERK1/2 and the nuclear translocation of transcription factors like NFAT and NF- $\kappa$ B.[10][11] Multiparametric flow cytometry allows for the simultaneous analysis of phosphorylation events in different T-cell subsets, identified by surface markers.[12]

## Troubleshooting Guides

### Western Blot for Phosphorylated ITK

Problem	Possible Cause	Recommended Solution
No Signal	Inefficient cell stimulation.	Optimize stimulation time and conditions. ITK phosphorylation can be transient.[5]
Protein degradation or dephosphorylation during sample preparation.	Keep samples on ice, use pre-chilled buffers, and add protease and phosphatase inhibitors to the lysis buffer.[6]	
Low abundance of phosphorylated ITK.	Increase the amount of protein loaded on the gel (up to 100 $\mu$ g for modified proteins).[6] Consider immunoprecipitation to enrich for ITK before blotting.	
Ineffective primary or secondary antibody.	Ensure antibodies are validated for the application and stored correctly. Use a positive control to verify antibody function.	
High Background	Blocking agent is inappropriate.	Avoid using milk as a blocking agent due to its casein content. Use Bovine Serum Albumin (BSA) or a protein-free blocker instead.
Insufficient washing.	Increase the number and duration of wash steps with TBST.[13]	
Primary antibody concentration is too high.	Titrate the primary antibody to determine the optimal concentration.[13]	
Non-specific Bands	Antibody is not specific enough.	Use an affinity-purified antibody. Include a negative control (e.g., lysate from ITK-deficient cells) to confirm band specificity.
Protein aggregation or multimers.	Boil samples in Laemmli buffer for a longer duration (e.g., 10 minutes) to disrupt protein complexes.[13]	

### Flow Cytometry for ITK Signaling

Problem	Possible Cause	Recommended Solution
Weak Phospho-signal	Suboptimal cell stimulation.	Perform a time-course experiment to determine the peak of phosphorylation for your target.[5]
Inadequate cell permeabilization.	Ensure the correct permeabilization buffer (e.g., containing saponin or Triton X-100) is used for intracellular staining.[14]	
Loss of phospho-epitope during fixation.	Use a fixation method that preserves phosphorylation sites. Formaldehyde-based fixatives are generally recommended.[5]	
High Background Staining	Non-specific antibody binding.	Include an isotype control to assess non-specific binding. Block Fc receptors before adding the primary antibody.
Incomplete washing.	Ensure thorough washing after antibody incubation steps.[15]	
Difficulty Gating on Cell Populations	Poor separation of positive and negative populations.	Titrate the antibody to find the optimal concentration that maximizes the signal-to-noise ratio.
Instrument settings are not optimized.	Adjust photomultiplier tube (PMT) voltages to ensure proper signal detection and separation.	

## Experimental Protocols

### Detailed Methodology for Western Blotting of Phosphorylated ITK

- **Cell Culture and Stimulation:** Culture T-cells (e.g., Jurkat) or primary T-cells under standard conditions. Stimulate cells with an appropriate agonist (CD3/CD28 antibodies) for the optimized duration to induce ITK phosphorylation.
- **Cell Lysis:** After stimulation, immediately place cells on ice. Wash once with ice-cold PBS. Lyse the cells in ice-cold RIPA buffer supplemented with cocktail of protease and phosphatase inhibitors.
- **Protein Quantification:** Determine the protein concentration of the lysates using a standard method like the BCA assay.
- **Sample Preparation:** Mix equal amounts of protein (20-50 µg) with Laemmli sample buffer and boil for 5-10 minutes at 95°C.
- **SDS-PAGE and Transfer:** Separate the protein lysates on an SDS-polyacrylamide gel. Transfer the separated proteins to a PVDF or nitrocellulose membrane.
- **Blocking:** Block the membrane for 1 hour at room temperature with 5% BSA in Tris-buffered saline with 0.1% Tween-20 (TBST). Avoid using non-fat milk.
- **Primary Antibody Incubation:** Incubate the membrane with a primary antibody specific for phosphorylated ITK (e.g., p-ITK Tyr511) diluted in 5% BSA/TBST overnight at 4°C with gentle agitation.
- **Washing:** Wash the membrane three times for 10 minutes each with TBST.
- **Secondary Antibody Incubation:** Incubate the membrane with an HRP-conjugated secondary antibody diluted in 5% BSA/TBST for 1 hour at room temperature.
- **Detection:** Wash the membrane as in step 8. Detect the signal using an enhanced chemiluminescence (ECL) substrate and an imaging system.
- **Stripping and Re-probing (Optional):** To normalize for protein loading, the membrane can be stripped and re-probed with an antibody against total ITK.

### Detailed Methodology for Flow Cytometric Analysis of ITK Signaling

- **Cell Stimulation:** Stimulate T-cells in suspension with the desired agonist for various time points.

- **Fixation:** Immediately after stimulation, fix the cells by adding formaldehyde to a final concentration of 1.6% and incubate for 10 minutes at room temperature. This step cross-links proteins and inactivates phosphatases.[5]
- **Permeabilization:** Wash the fixed cells with PBS. Permeabilize the cells by adding ice-cold 90% methanol and incubating on ice for 30 minutes, or a detergent-based permeabilization buffer.
- **Staining:** Wash the permeabilized cells with staining buffer (e.g., PBS with 2% FBS). Stain with fluorescently-conjugated antibodies against surface (to identify T-cell subsets) and intracellular phospho-proteins (e.g., p-PLC $\gamma$ 1, p-ERK) for 30-60 minutes at room temperature, protected from light.
- **Washing:** Wash the cells twice with staining buffer.
- **Data Acquisition:** Resuspend the cells in staining buffer and acquire data on a flow cytometer. Ensure that enough events are collected for robust analysis.
- **Data Analysis:** Analyze the data using appropriate flow cytometry software. Gate on the cell population of interest based on forward and side scatter then on specific T-cell subsets using surface markers. Analyze the expression of phospho-proteins within these gated populations.

## Detailed Methodology for In Vitro ITK Kinase Assay

- **Prepare Reagents:** Thaw recombinant active ITK, kinase assay buffer, substrate (e.g., a synthetic peptide or myelin basic protein), and ATP on ice.
- **Kinase Reaction Setup:** In a microcentrifuge tube or 96-well plate, combine the kinase assay buffer, the substrate, and the test compound (inhibitor control).
- **Initiate Reaction:** Add a working solution of ATP (containing  $\gamma$ - $^{32}$ P-ATP for radioactive assays or unlabeled ATP for luminescence-based assays) to the kinase reaction.
- **Incubation:** Incubate the reaction mixture at 30°C for a predetermined optimal time (e.g., 15-60 minutes).
- **Terminate Reaction:** Stop the reaction. For radioactive assays, this can be done by adding a solution like 1% phosphoric acid and spotting the mixture on P81 phosphocellulose paper. For luminescence-based assays, an ADP-Glo™ Reagent is added to stop the reaction and deplete the remaining ATP.
- **Detection and Quantification:**
  - **Radioactive Assay:** Wash the P81 paper to remove unincorporated  $\gamma$ - $^{32}$ P-ATP. Measure the incorporated radioactivity using a scintillation counter.
  - **Luminescence-based Assay:** Add a kinase detection reagent that converts the generated ADP to ATP, which is then used in a luciferase reaction to produce light. Measure the luminescent signal with a luminometer.
- **Data Analysis:** Calculate the kinase activity based on the measured signal, and determine the effect of any test compounds.

## Visualizing ITK Signaling Pathways

To aid in the understanding of the complex interactions within the ITK signaling cascade, the following diagrams have been generated using Graphviz

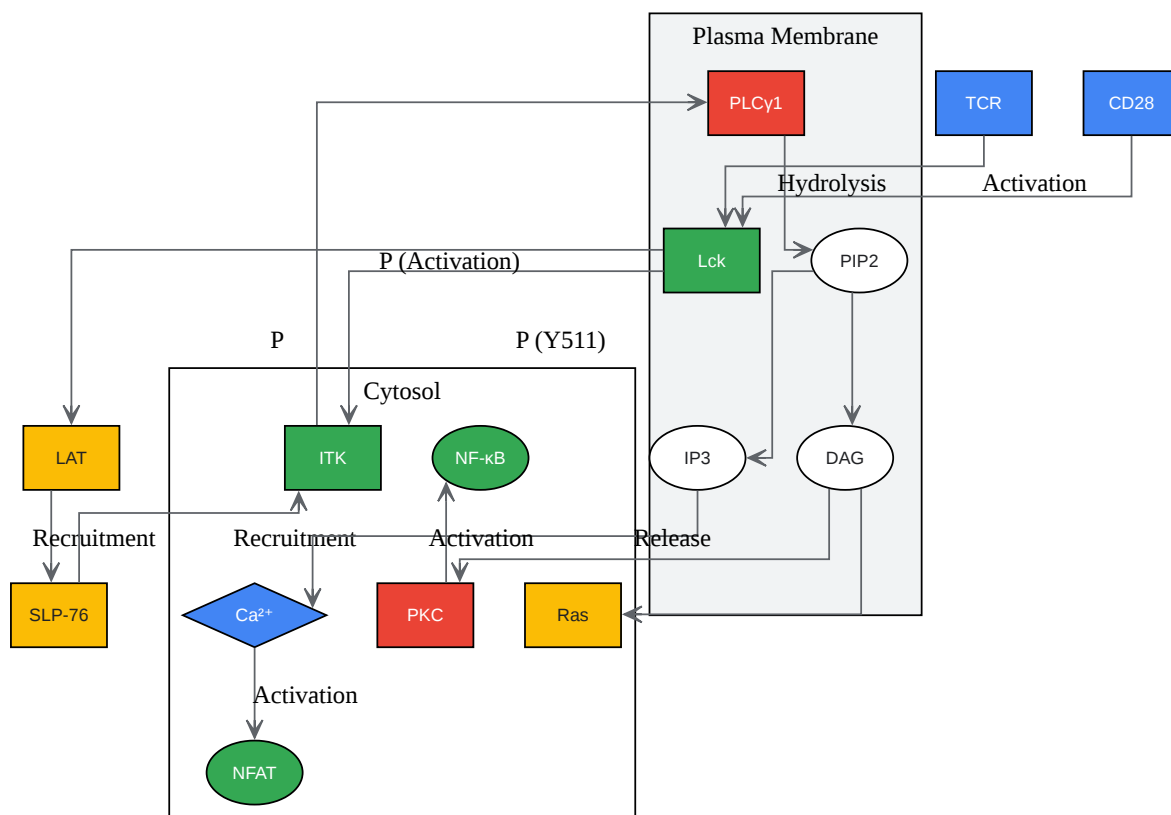

[Click to download full resolution via product page](#)

Caption: Core ITK signaling pathway upon T-cell receptor (TCR) activation.

```
graph Troubleshooting_Workflow {
graph [rankdir="TB", splines=ortho, nodesep=0.5];
node [shape=box, style="filled", fontname="Arial", fontsize=10, fontcolor="#202124"];
edge [arrowhead=vee, color="#5F6368"];

```

```
Start [label="No/Weak p-ITK Signal\nin Western Blot", shape=ellipse, fillcolor="#EA4335", fontcolor="#FFFFFF"]
CheckStimulation [label="Verify Cell Stimulation\n(Time course, Agonist conc.)", shape=diamond, fillcolor="#F1F3F4"]
CheckLysis [label="Check Lysis Buffer\n(Fresh inhibitors?)", shape=diamond, fillcolor="#FBBC05"]
CheckLoading [label="Quantify & Increase\nProtein Load", shape=diamond, fillcolor="#FBBC05"]
CheckAntibody [label="Validate Antibody\n(Positive Control)", shape=diamond, fillcolor="#FBBC05"]
CheckBlocking [label="Review Blocking Step\n(Avoid Milk)", shape=diamond, fillcolor="#FBBC05"]
Success [label="Signal Restored", shape=ellipse, fillcolor="#34A853", fontcolor="#FFFFFF"]
FurtherTroubleshooting [label="Consult Further\n(e.g., IP-Western)", fillcolor="#F1F3F4"]

```

```
Start -> CheckStimulation;  
CheckStimulation -> CheckLysis [label="Stimulation OK"];  
CheckLysis -> CheckLoading [label="Lysis OK"];  
CheckLoading -> CheckAntibody [label="Loading OK"];  
CheckAntibody -> CheckBlocking [label="Antibody OK"];  
CheckBlocking -> FurtherTroubleshooting [label="Blocking OK"];
```

```
CheckStimulation -> Success [label="Issue Found"];  
CheckLysis -> Success [label="Issue Found"];  
CheckLoading -> Success [label="Issue Found"];  
CheckAntibody -> Success [label="Issue Found"];  
CheckBlocking -> Success [label="Issue Found"];  
}
```

Caption: Troubleshooting workflow for absent or weak phosphorylated ITK signal in Western blots.

#### Need Custom Synthesis?

BenchChem offers custom synthesis for rare earth carbides and specific isotopic labeling.

Email: [info@benchchem.com](mailto:info@benchchem.com) or [Request Quote Online](#).

## References

1. T-Cell Signaling Regulated by the Tec Family Kinase, Itk - PMC [[pmc.ncbi.nlm.nih.gov](https://pubmed.ncbi.nlm.nih.gov/)]
2. [promega.com](https://www.promega.com) [[promega.com](https://www.promega.com)]
3. Targeting Interleukin-2-Inducible T-cell Kinase (ITK) in T-Cell Related Diseases - PMC [[pmc.ncbi.nlm.nih.gov](https://pubmed.ncbi.nlm.nih.gov/)]
4. T Cell Receptor Signaling | Cell Signaling Technology [[cellsignal.com](https://www.cellsignal.com)]
5. [m.youtube.com](https://www.youtube.com) [[m.youtube.com](https://www.youtube.com)]
6. Western Blotting Troubleshooting Guide | Cell Signaling Technology [[cellsignal.com](https://www.cellsignal.com)]
7. [researchgate.net](https://www.researchgate.net) [[researchgate.net](https://www.researchgate.net)]
8. [bpsbioscience.com](https://www.bpsbioscience.com) [[bpsbioscience.com](https://www.bpsbioscience.com)]
9. In Silico Modeling of Itk Activation Kinetics in Thymocytes Suggests Competing Positive and Negative IP4 Mediated Feedbacks Increase Robust PLOS One [[journals.plos.org](https://journals.plos.org)]
10. [pnas.org](https://www.pnas.org) [[pnas.org](https://www.pnas.org)]
11. Hierarchy of signaling thresholds downstream of the T cell receptor and the Tec kinase ITK - PMC [[pmc.ncbi.nlm.nih.gov](https://pubmed.ncbi.nlm.nih.gov/)]
12. Flow Cytometric Analysis of Cell Signaling Proteins | Springer Nature Experiments [[experiments.springernature.com](https://www.experiments.springernature.com)]
13. [docs.abcam.com](https://www.docs.abcam.com) [[docs.abcam.com](https://www.docs.abcam.com)]
14. (IC) Intracellular Staining Flow Cytometry Protocol Using Detergents: R&D Systems [[rndsystems.com](https://www.rndsystems.com)]
15. [lerner.ccf.org](https://www.lerner.ccf.org) [[lerner.ccf.org](https://www.lerner.ccf.org)]
- To cite this document: BenchChem. [Interpreting complex data from ITK signaling studies]. BenchChem, [2026]. [Online PDF]. Available at: [<https://www.benchchem.com/product/b15541571/docs#interpreting-complex-data-from-itk-signaling-studies>]

#### Disclaimer & Data Validity:

The information provided in this document is for Research Use Only (RUO) and is strictly not intended for diagnostic or therapeutic procedures. While BenchChem strives to provide accurate protocols, we make no warranties, express or implied, regarding the fitness of this product for every specific experimental setup.

**Technical Support:** The protocols provided are for reference purposes. Unsure if this reagent suits your experiment?

**Need Industrial/Bulk Grade?** [Request Custom Synthesis Quote](#)

## BenchChem

Our mission is to be the trusted global source of essential and advanced chemicals, empowering scientists and researchers to drive progress in science and industry.

### Contact

Address: 3281 E Guasti Rd

Ontario, CA 91761, United States

Phone: (601) 213-4426

Email: [info@benchchem.com](mailto:info@benchchem.com)

[Contact our Ph.D. Support Team for a compatibility check](#)