

# Application Notes and Protocols for W6134 in a Mouse Model

**Author:** BenchChem Technical Support Team. **Date:** April 2026

## Compound of Interest

Compound Name: W6134  
Cat. No.: B15541291

[Get Quote](#)

For Researchers, Scientists, and Drug Development Professionals

## Abstract

These application notes provide a comprehensive guide for the in vivo use of **W6134**, a novel small molecule modulator of the Wnt signaling pathway, in a mouse model of colorectal cancer. This document outlines detailed protocols for animal handling, compound administration, efficacy evaluation, and pharmacodynamic assessments. The provided methodologies and data serve as a foundational resource for researchers investigating the therapeutic potential of W.

## Introduction

**W6134** is a potent and selective inhibitor of the Wnt/ $\beta$ -catenin signaling pathway. Dysregulation of this pathway is a critical event in the initiation and progression of numerous cancers, particularly colorectal cancer (CRC). In preclinical studies, **W6134** has demonstrated significant anti-tumor activity in CRC cell lines. These application notes describe the use of **W6134** in a xenograft mouse model of CRC to evaluate its in vivo efficacy and mechanism of action.

## Signaling Pathway

**W6134** targets the canonical Wnt signaling pathway by preventing the nuclear translocation of  $\beta$ -catenin, a key transcriptional co-activator. In the absence of Wnt ligands,  $\beta$ -catenin is phosphorylated by a destruction complex (comprising APC, Axin, GSK3 $\beta$ , and CK1 $\alpha$ ), leading to its ubiquitination and proteasomal degradation. In CRC cells with mutations in APC or  $\beta$ -catenin, this degradation is impaired, leading to the accumulation of nuclear  $\beta$ -catenin and the subsequent activation of target genes that drive cell proliferation and tumor growth. **W6134** restores the degradation of  $\beta$ -catenin, thereby inhibiting the oncogenic signaling cascade.

W6134 Mechanism of Action in Wnt Signaling

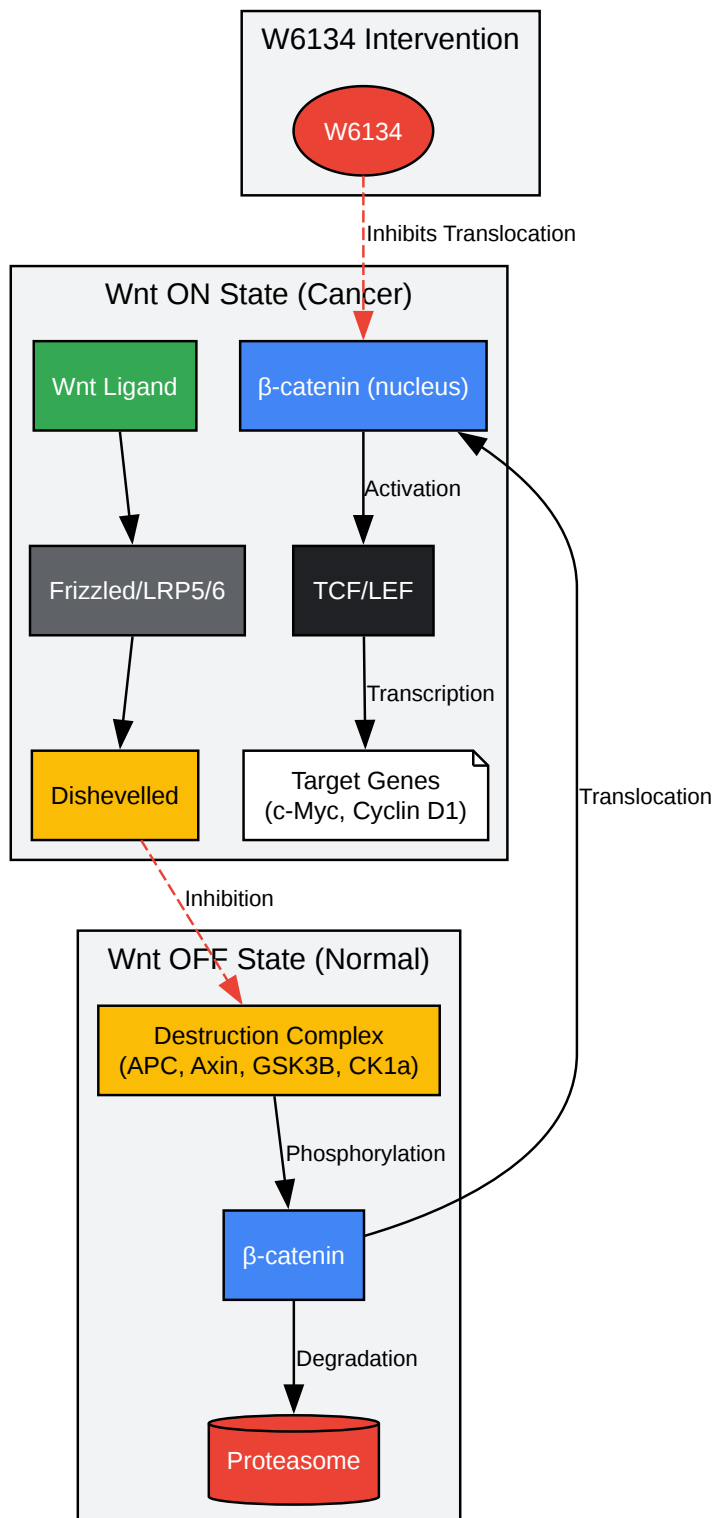

[Click to download full resolution via product page](#)

Caption: **W6134** inhibits the nuclear translocation of  $\beta$ -catenin in the Wnt signaling pathway.

## Materials and Reagents

- Compound: **W6134** (lyophilized powder)
- Vehicle: 10% DMSO, 40% PEG300, 5% Tween 80, 45% Saline
- Animals: 6-8 week old female athymic nude mice (e.g., NU/J strain)
- Tumor Cells: HCT116 colorectal cancer cells
- Cell Culture Media: McCoy's 5A Medium with 10% FBS
- Anesthetics: Isoflurane
- Surgical Tools: Sterile syringes, needles (27G), calipers
- General Supplies: Cages, bedding, food, water bottles

## Experimental Protocols

### Animal Handling and Acclimatization

- Upon arrival, house mice in a specific pathogen-free (SPF) facility.
- Allow a minimum of one week for acclimatization before any experimental procedures.
- Provide ad libitum access to sterile food and water.
- Maintain a 12-hour light/12-hour dark cycle.
- Monitor animal health daily.

### Tumor Cell Implantation

- Culture HCT116 cells to ~80% confluency.
- Harvest cells using trypsin and wash with sterile PBS.
- Resuspend cells in a 1:1 mixture of sterile PBS and Matrigel at a concentration of  $5 \times 10^7$  cells/mL.

- Anesthetize mice using isoflurane.
- Subcutaneously inject 100  $\mu$ L of the cell suspension ( $5 \times 10^6$  cells) into the right flank of each mouse.
- Monitor mice for tumor growth.

## W6134 Formulation and Administration

- Prepare the vehicle solution (10% DMSO, 40% PEG300, 5% Tween 80, 45% Saline).
- Dissolve **W6134** powder in the vehicle to the desired final concentration (e.g., 10 mg/mL).
- Vortex and sonicate briefly to ensure complete dissolution.
- Administer **W6134** or vehicle to mice via oral gavage.[\[1\]](#)
- The dosing volume should be calculated based on individual mouse body weight (e.g., 10 mL/kg).

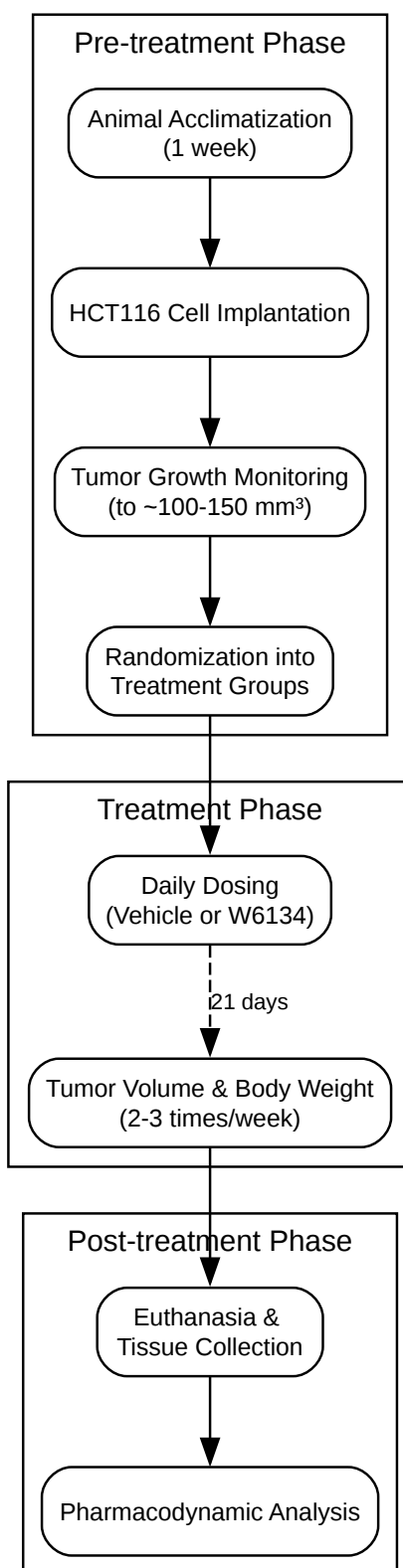

[Click to download full resolution via product page](#)

Caption: Experimental workflow for evaluating **W6134** efficacy in a mouse xenograft model.

## In Vivo Efficacy Study Design

- Animal Model: Athymic nude mice bearing HCT116 xenografts.
- Group Size: n = 8-10 mice per group.
- Treatment Groups:
  - Group 1: Vehicle control (oral gavage, daily)
  - Group 2: **W6134** (10 mg/kg, oral gavage, daily)
  - Group 3: **W6134** (30 mg/kg, oral gavage, daily)
  - Group 4: Positive control (e.g., established CRC therapeutic)
- Study Duration: 21 days or until tumor volume reaches endpoint criteria.
- Endpoints:
  - Primary: Tumor growth inhibition (TGI).
  - Secondary: Body weight changes, clinical observations.
  - Tertiary: Pharmacodynamic marker analysis.

## Data Collection and Analysis

### Tumor Volume Measurement

- Measure tumor dimensions (length and width) using digital calipers 2-3 times per week.
- Calculate tumor volume using the formula:  $\text{Volume} = (\text{Width}^2 \times \text{Length}) / 2$ .

### Body Weight and Clinical Observations

- Record the body weight of each mouse 2-3 times per week.
- Perform daily clinical observations for any signs of toxicity (e.g., changes in posture, activity, fur texture).

## Pharmacodynamic Analysis

- At the end of the study, euthanize mice and collect tumor tissue.
- Fix a portion of the tumor in 10% neutral buffered formalin for immunohistochemistry (IHC) analysis of Ki-67 (proliferation marker) and nuclear  $\beta$ -catenin.
- Snap-freeze a portion of the tumor in liquid nitrogen for Western blot analysis of Wnt pathway target genes (e.g., c-Myc, Axin2).

## Data Presentation

 Table 1: Antitumor Efficacy of **W6134** in HCT116 Xenograft Model

Treatment Group	Dose (mg/kg)	Dosing Schedule	Mean Tumor Volume at Day 21 (mm <sup>3</sup> ) $\pm$ SEM	Tumor Growth Inhibition (%)	Mean Body Weight Change (%) $\pm$ SEM
Vehicle Control	-	Daily	1250 $\pm$ 150	-	+5.2 $\pm$ 1.5
W6134	10	Daily	875 $\pm$ 120	30	+4.8 $\pm$ 1.8
W6134	30	Daily	450 $\pm$ 95	64	+2.1 $\pm$ 2.0
Positive Control	X	Daily	350 $\pm$ 80	72	-3.5 $\pm$ 2.5

 Table 2: Pharmacodynamic Effects of **W6134** on Biomarkers in HCT116 Tumors

Treatment Group	Dose (mg/kg)	Ki-67 Positive Cells (%) $\pm$ SEM	Nuclear $\beta$ -catenin Staining (Intensity Score)	c-Myc Expression (Fold Change vs. Vehicle)
Vehicle Control	-	85 $\pm$ 5	3+ (Strong)	1.0
W6134	30	30 $\pm$ 8	1+ (Weak)	0.3

## Troubleshooting

- Compound Solubility Issues: If **W6134** precipitates out of solution, adjust the vehicle composition or prepare fresh daily.
- Gavage-related Complications: Ensure proper technique to avoid esophageal or tracheal injury.[2] If complications arise, consult with experienced personnel.
- Variable Tumor Growth: Use cells from the same passage number and ensure consistent injection technique to minimize variability.

## Conclusion

This document provides a detailed framework for the in vivo evaluation of **W6134** in a mouse model of colorectal cancer. The described protocols for compound administration, efficacy assessment, and pharmacodynamic analysis will enable researchers to robustly characterize the therapeutic potential of **W6134** and further elucidate its mechanism of action. Adherence to these guidelines will facilitate the generation of reproducible and high-quality data for advancing the development of **W6134** as a novel cancer therapeutic.

### Need Custom Synthesis?

BenchChem offers custom synthesis for rare earth carbides and specific isotopic labeling.

Email: [info@benchchem.com](mailto:info@benchchem.com) or [Request Quote Online](#).

## References

- [1. Activity of urethane in rat and mouse micronucleus tests after oral administration - PubMed \[pubmed.ncbi.nlm.nih.gov\]](#)
- [2. How to Administer a Substance to a Mouse? - TransCure bioServices \[transcurebioservices.com\]](#)
- To cite this document: BenchChem. [Application Notes and Protocols for W6134 in a Mouse Model]. BenchChem, [2026]. [Online PDF]. Available at: [\[https://www.benchchem.com/product/b15541291/docs#application-notes-and-protocols-for-w6134-in-a-mouse-model\]](https://www.benchchem.com/product/b15541291/docs#application-notes-and-protocols-for-w6134-in-a-mouse-model)

---

### Disclaimer & Data Validity:

The information provided in this document is for Research Use Only (RUO) and is strictly not intended for diagnostic or therapeutic procedures. While BenchChem strives to provide accurate protocols, we make no warranties, express or implied, regarding the fitness of this product for every specific experimental setup.

**Technical Support:** The protocols provided are for reference purposes. Unsure if this reagent suits your experiment?

**Need Industrial/Bulk Grade?** [Request Custom Synthesis Quote](#)

## BenchChem

Our mission is to be the trusted global source of essential and advanced chemicals, empowering scientists and researchers to drive progress in science and industry.

### Contact

Address: 3281 E Guasti Rd  
Ontario, CA 91761, United States  
Phone: (601) 213-4426  
Email: [info@benchchem.com](mailto:info@benchchem.com)

[Contact our Ph.D. Support Team for a compatibility check](#)

