

Application Notes and Protocols for Pomalidomide In-Vivo Animal Studies

Author: BenchChem Technical Support Team. **Date:** April 2026

Compound of Interest

Compound Name: Pomalidomide-cyclohexane

Cat. No.: B15541094

[Get Quote](#)

A Foundational Guide for Researchers, Scientists, and Drug Development Professionals

Disclaimer: The following application notes and protocols are based on publicly available information for pomalidomide. The user's request specified "**pomalidomide-cyclohexane**," for which no specific in-vivo data was found in the public domain. It is presumed that "**pomalidomide-cyclohexane**" may be a novel conjugate or a specific formulation. Therefore, the information provided herein for pomalidomide should be considered a foundational template. Researchers working with "**pomalidomide-cyclohexane**" or any derivative must conduct specific validation studies to determine the appropriate experimental parameters.

Introduction

Pomalidomide is a third-generation immunomodulatory drug (IMiD) with potent anti-neoplastic, anti-angiogenic, and immunomodulatory activities.[1][2][3] It is an analog of thalidomide and is approved for the treatment of relapsed and refractory multiple myeloma.[4][5] Pomalidomide's mechanism of action is centered on its ability to bind to the Cereblon (CRBN) protein, a substrate receptor of the CRL4-CRBN E3 ubiquitin ligase complex.[4][6] This binding event leads to the ubiquitination and subsequent proteasomal degradation of neo-substrates, including the lymphoid transcription factors Ikaros (IKZF1) and Aiolos (IKZF3).[6][7] The

degradation of these transcription factors results in direct anti-proliferative and pro-apoptotic effects on tumor cells, as well as modulation of the tumor microenvironment.[5][6]

These application notes provide a comprehensive overview of the use of pomalidomide in in-vivo animal studies, including detailed experimental protocols, quantitative data summaries, and visualizations of key signaling pathways and workflows.

Data Presentation

Table 1: Pomalidomide Pharmacokinetic Parameters in Animals and Humans

Species	Administration Route	Dose	Cmax (ng/mL)	Tmax (hours)	Half-life (hours)	Bioavailability (%)	Reference
Rat	PO	50 mg/kg	1100 ± 82	4.6 ± 2.4	-	47.4	[8]
Monkey	IV	-	-	-	4 - 7	-	[9]
Human (Healthy)	PO	2 mg (single dose)	-	2 - 3	~9.4	>70	[10][11]
Human (Multiple Myeloma)	PO	4 mg (daily)	75	-	~7.5	-	[9][12]

Table 2: Pomalidomide-Related Toxicities in Animal Models

Species	Key Toxicities Observed	Reference
Rat	Teratogenic (fetal visceral defects, vertebral abnormalities)	[4][13]
Rabbit	Teratogenic (cardiac malformations, limb and digit anomalies)	[4][13]
Monkey	Reduction in platelet and WBC counts, lymphoid depletion, gastrointestinal inflammation, infection. One case of acute myeloid leukemia (AML) at high dose after 9 months.	[4]

Experimental Protocols

Protocol 1: General Animal Husbandry and Acclimatization

- **Animal Model:** Select an appropriate animal model based on the research question (e.g., immunodeficient mice for xenograft studies, transgenic models).
- **Housing:** House animals in a controlled environment with a 12-hour light/dark cycle, constant temperature ($22 \pm 2^{\circ}\text{C}$), and humidity ($55 \pm 10\%$). Provide ad libitum access to food and water.[14]
- **Acclimatization:** Allow a minimum of one week for animals to acclimatize to the facility before initiating any experimental procedures.[14]
- **Ethics:** All animal experiments must be conducted in accordance with institutional and national guidelines for animal welfare and approved by the Institutional Animal Care and Use Committee (IACUC).

Protocol 2: Pomalidomide Formulation and Administration

- **Formulation:** Pomalidomide can be formulated as a suspension for oral administration. A common vehicle is 1% carboxymethyl cellulose in saline.[15] For intravenous administration, a solution containing DMSO, PEG300, and Tween 80 in saline can be used, though specific solubility testing is crucial.[14]
- **Preparation:** Prepare the formulation fresh on the day of dosing.
- **Administration:**
 - **Oral (PO):** Administer via oral gavage. For mice, a typical volume is 0.1 mL/10 g body weight. For rats, 0.1 mL/100 g body weight is common.[15]
 - **Intravenous (IV):** Administer via a suitable vein (e.g., tail vein in mice).
 - **Intraperitoneal (IP):** Administer into the peritoneal cavity.

Protocol 3: In-Vivo Efficacy Study in a Multiple Myeloma Xenograft Model

- **Cell Culture:** Culture human multiple myeloma cells (e.g., MM.1S) in appropriate media.
- **Tumor Implantation:** Subcutaneously inject a suspension of tumor cells (e.g., 5×10^6 cells in 100 μ L of PBS/Matrigel) into the flank of immunodeficient mice (e.g., NOD/SCID or NSG).
- **Tumor Growth Monitoring:** Monitor tumor growth by measuring tumor volume with calipers (Volume = $0.5 \times \text{Length} \times \text{Width}^2$).
- **Randomization:** When tumors reach a predetermined size (e.g., 100-150 mm^3), randomize animals into treatment and control groups.
- **Dosing:**
 - **Treatment Group:** Administer pomalidomide at a predetermined dose and schedule (e.g., 3-30 mg/kg, daily, PO).[8]

- Control Group: Administer the vehicle solution following the same schedule.
- Endpoint Analysis:
 - Monitor tumor volume and body weight regularly (e.g., 2-3 times per week).
 - At the end of the study (based on tumor size limits or a fixed duration), euthanize the animals and collect tumors and other relevant tissues for further analysis (e.g., histology, immunohistochemistry, Western blotting).

Protocol 4: Pharmacokinetic Study

- Animal Model: Use a suitable rodent or non-rodent model (e.g., C57BL/6 mice or Sprague-Dawley rats).
- Drug Administration: Administer a single dose of pomalidomide via the desired route (e.g., PO or IV).
- Sample Collection:
 - Collect blood samples (approximately 50-100 μ L) at multiple time points post-dose (e.g., 0, 0.25, 0.5, 1, 2, 4, 6, 8, 12, and 24 hours for PO; earlier time points for IV).[14]
 - Collect samples from the saphenous vein or via cardiac puncture for terminal collection into tubes containing an anticoagulant (e.g., K2-EDTA).
 - For brain penetration studies, collect brain tissue at the same time points.[15]
- Sample Processing: Centrifuge blood samples to separate plasma. Store plasma and tissue samples at -80°C until analysis.
- Bioanalysis: Quantify pomalidomide concentrations in plasma and tissue homogenates using a validated analytical method, such as liquid chromatography-mass spectrometry (LC-MS/MS).[15]
- Data Analysis: Calculate pharmacokinetic parameters (C_{max} , T_{max} , AUC, half-life) using appropriate software.

Visualizations

Pomalidomide's Mechanism of Action

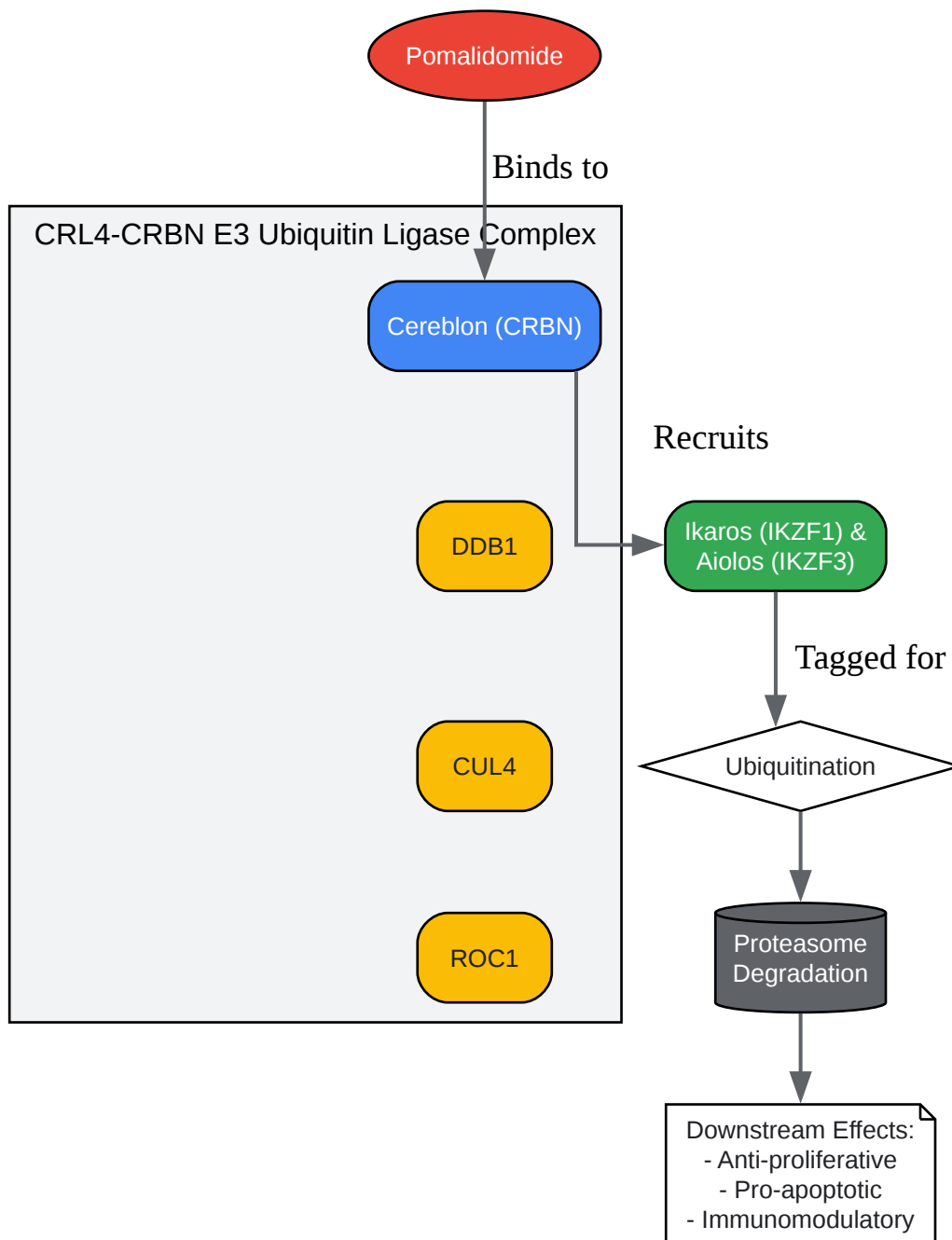

[Click to download full resolution via product page](#)

Caption: Pomalidomide binds to CRBN, inducing the ubiquitination and degradation of IKZF1/3, leading to downstream anti-tumor effects.

Experimental Workflow for an In-Vivo Efficacy Study

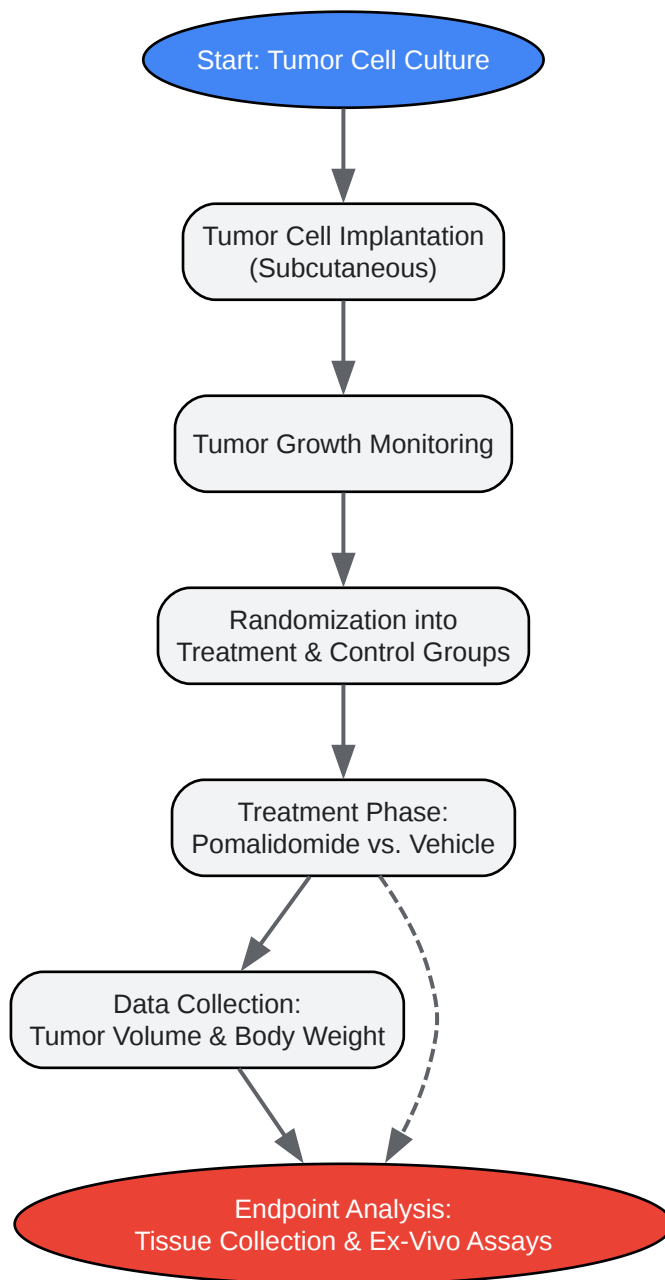

[Click to download full resolution via product page](#)

Caption: A typical workflow for evaluating the efficacy of pomalidomide in a xenograft mouse model.

Need Custom Synthesis?

BenchChem offers custom synthesis for rare earth carbides and specific isotopic labeling.

Email: info@benchchem.com or [Request Quote Online](#).

References

- [1. discovery.researcher.life](https://discovery.researcher.life) [discovery.researcher.life]
- [2. What is the mechanism of Pomalidomide?](https://synapse.patsnap.com) [synapse.patsnap.com]
- [3. Pomalidomide - LiverTox - NCBI Bookshelf](https://pubmed.ncbi.nlm.nih.gov) [[ncbi.nlm.nih.gov](https://pubmed.ncbi.nlm.nih.gov)]
- [4. accessdata.fda.gov](https://accessdata.fda.gov) [accessdata.fda.gov]
- [5. Pomalidomide: the new immunomodulatory agent for the treatment of multiple myeloma - PMC](https://pubmed.ncbi.nlm.nih.gov) [[pmc.ncbi.nlm.nih.gov](https://pubmed.ncbi.nlm.nih.gov)]
- [6. benchchem.com](https://www.benchchem.com) [[benchchem.com](https://www.benchchem.com)]
- [7. bocsci.com](https://www.bocsci.com) [[bocsci.com](https://www.bocsci.com)]
- [8. Pomalidomide Shows Significant Therapeutic Activity against CNS Lymphoma with a Major Impact on the Tumor Microenvironment in Murine Models - PMC](https://pubmed.ncbi.nlm.nih.gov) [[pmc.ncbi.nlm.nih.gov](https://pubmed.ncbi.nlm.nih.gov)]
- [9. Pomalidomide | E3 ligase ligand | TNFa inhibitor | anti-angiogenic agent | immunomodulator | CAS 19171-19-8 | CC-4047 | actimid | InvivoChem](https://www.invivochem.com) [[invivochem.com](https://www.invivochem.com)]
- [10. go.drugbank.com](https://go.drugbank.com) [go.drugbank.com]
- [11. Population Pharmacokinetics of Pomalidomide - PMC](https://pubmed.ncbi.nlm.nih.gov) [[pmc.ncbi.nlm.nih.gov](https://pubmed.ncbi.nlm.nih.gov)]
- [12. Pomalidomide is strongly antiangiogenic and teratogenic in relevant animal models - PMC](https://pubmed.ncbi.nlm.nih.gov) [[pmc.ncbi.nlm.nih.gov](https://pubmed.ncbi.nlm.nih.gov)]
- [13. Pomalidomide is teratogenic in rats and rabbits and can be neurotoxic in humans - PMC](https://pubmed.ncbi.nlm.nih.gov) [[pmc.ncbi.nlm.nih.gov](https://pubmed.ncbi.nlm.nih.gov)]
- [14. benchchem.com](https://www.benchchem.com) [[benchchem.com](https://www.benchchem.com)]
- [15. Pomalidomide Reduces Ischemic Brain Injury in Rodents - PMC](https://pubmed.ncbi.nlm.nih.gov) [[pmc.ncbi.nlm.nih.gov](https://pubmed.ncbi.nlm.nih.gov)]
- To cite this document: BenchChem. [Application Notes and Protocols for Pomalidomide In-Vivo Animal Studies]. BenchChem, [2026]. [Online PDF]. Available at: [<https://www.benchchem.com/product/b15541094/docs#application-notes-and-protocols-for-pomalidomide-in-vivo-animal-studies>]

Disclaimer & Data Validity:

The information provided in this document is for Research Use Only (RUO) and is strictly not intended for diagnostic or therapeutic procedures. While BenchChem strives to provide accurate protocols, we make no warranties, express or implied, regarding the fitness of this product for every specific experimental setup.

Technical Support: The protocols provided are for reference purposes. Unsure if this reagent suits your experiment?

Need Industrial/Bulk Grade? [Request Custom Synthesis Quote](#)

BenchChem

Our mission is to be the trusted global source of essential and advanced chemicals, empowering scientists and researchers to drive progress in science and industry.

Contact

Address: 3281 E Guasti Rd
Ontario, CA 91761, United States
Phone: (601) 213-4426
Email: info@benchchem.com

[Contact our Ph.D. Support Team for a compatibility check](#)