

# Application Notes and Protocols for JNJ-7706204 in Cell Synchronization Experiments

**Author:** BenchChem Technical Support Team. **Date:** May 2026

## Compound of Interest

Compound Name: JNJ-6204

Cat. No.: B15541541

[Get Quote](#)

For Researchers, Scientists, and Drug Development Professionals

## Introduction

JNJ-7706204, also identified as JNJ-7706621, is a potent small molecule inhibitor with a dual mechanism of action, targeting both cyclin-dependent kinases (CDKs) and Aurora kinases.[1] [2] This dual inhibition disrupts the normal progression of the cell cycle, leading to a robust arrest of cells in the G2/M phase.[1][3] Specifically, JNJ-7706204 potently inhibits CDK1 and CDK2, key regulators of cell cycle transitions, as well as Aurora kinases A and B, which are crucial for mitotic events.[2][4][5] This property makes JNJ-7706204 a valuable tool for cell synchronization experiments, allowing researchers to enrich a cell population in the G2/M phase for various downstream applications.

These application notes provide a comprehensive guide for utilizing JNJ-7706204 to achieve cell cycle synchronization. Included are detailed protocols for cell treatment, cell cycle analysis by flow cytometry, and key quantitative data to guide experimental design.

## Mechanism of Action

JNJ-7706204 exerts its cell cycle effects by inhibiting two critical families of kinases:

- Cyclin-Dependent Kinases (CDKs): By inhibiting CDK1/Cyclin B, the primary driver of entry into mitosis, JNJ-7706204 prevents cells from proceeding from G2 to M phase. Inhibition of other CDKs can also contribute to a delay in exiting the G1 phase.[1][3]
- Aurora Kinases: Inhibition of Aurora A and B kinases disrupts critical mitotic processes, including centrosome separation, spindle formation, and chromosome segregation, further contributing to the G2/M arrest.[1][6]

The combined inhibition of these kinase families results in a highly efficient block at the G2/M transition, leading to a synchronized population of cells.

## Data Presentation

### In Vitro Kinase Inhibitory Activity of JNJ-7706204

Kinase Target	IC50 (nM)
CDK1/Cyclin B	9
CDK2/Cyclin A	4
CDK2/Cyclin E	3
Aurora A	11
Aurora B	15

Data compiled from multiple sources.[2][4][5]

### Antiproliferative Activity of JNJ-7706204 in Human Cancer Cell Lines

Cell Line	Cancer Type	IC50 (nM)
HeLa	Cervical Adenocarcinoma	280 - 284
HCT-116	Colorectal Carcinoma	254
A375	Malignant Melanoma	447

Data compiled from multiple sources.[4][5]

## Experimental Protocols

### Protocol 1: Cell Synchronization using JNJ-7706204

This protocol describes the treatment of cultured mammalian cells with JNJ-7706204 to induce G2/M phase arrest.

#### Materials:

- Mammalian cell line of interest (e.g., HeLa, HCT-116)
- Complete cell culture medium
- JNJ-7706204 (stock solution in DMSO)
- Phosphate-Buffered Saline (PBS)
- Trypsin-EDTA
- Cell culture plates/flasks
- Incubator (37°C, 5% CO<sub>2</sub>)

#### Procedure:

- Cell Seeding: Seed cells at a density that will allow them to be in the exponential growth phase at the time of treatment. This is typically around 30-40% confluency.
- Cell Adherence: Allow cells to adhere and grow for 24 hours in a 37°C, 5% CO<sub>2</sub> incubator.
- JNJ-7706204 Treatment:
  - Prepare the desired concentration of JNJ-7706204 in complete cell culture medium. A concentration range of 0.5  $\mu$ M to 3  $\mu$ M is a good starting point for many cancer cell lines. [4] It is recommended to perform a dose-response experiment to determine the optimal concentration for your specific cell line.
  - Include a vehicle control (DMSO) at the same final concentration as the JNJ-7706204-treated samples.

- Aspirate the old medium from the cells and replace it with the medium containing JNJ-7706204 or the vehicle control.
- Incubation: Incubate the cells for 16-24 hours. The optimal incubation time may vary depending on the cell line and its doubling time. A time-course experiment is recommended to determine the point of maximal G2/M arrest.
- Cell Harvesting: After incubation, harvest the cells for downstream analysis (e.g., flow cytometry, western blotting, or immunofluorescence). For adherent cells, wash with PBS, detach with Trypsin-EDTA, and neutralize with complete medium. For suspension cells, collect by centrifugation.

## Protocol 2: Cell Cycle Analysis by Flow Cytometry (Propidium Iodide Staining)

This protocol outlines the steps for analyzing the cell cycle distribution of JNJ-7706204-treated cells using propidium iodide (PI) staining and flow cytometry.[7]

### Materials:

- Harvested cells (from Protocol 1)
- Ice-cold PBS
- Ice-cold 70% Ethanol
- Propidium Iodide (PI) staining solution (containing RNase A)
- Flow cytometer

### Procedure:

- Cell Fixation:
  - Centrifuge the harvested cell suspension at 300 x g for 5 minutes.
  - Discard the supernatant and resuspend the cell pellet in 500 µL of ice-cold PBS.

- While gently vortexing, add 4.5 mL of ice-cold 70% ethanol dropwise to fix the cells.[7]
- Incubate the cells on ice for at least 30 minutes or at -20°C for long-term storage.
- Cell Staining:
  - Centrifuge the fixed cells at 500 x g for 5 minutes.
  - Carefully decant the ethanol and wash the cell pellet with 5 mL of PBS.
  - Centrifuge again and discard the supernatant.
  - Resuspend the cell pellet in 500 µL of PI staining solution.
  - Incubate the cells in the dark at room temperature for 30 minutes.[7]
- Flow Cytometry Analysis:
  - Transfer the stained cells to flow cytometry tubes.
  - Analyze the samples on a flow cytometer, collecting data for at least 10,000 events per sample.
  - Use appropriate software to analyze the DNA content histograms and quantify the percentage of cells in the G0/G1, S, and G2/M phases of the cell cycle.

## Visualizations

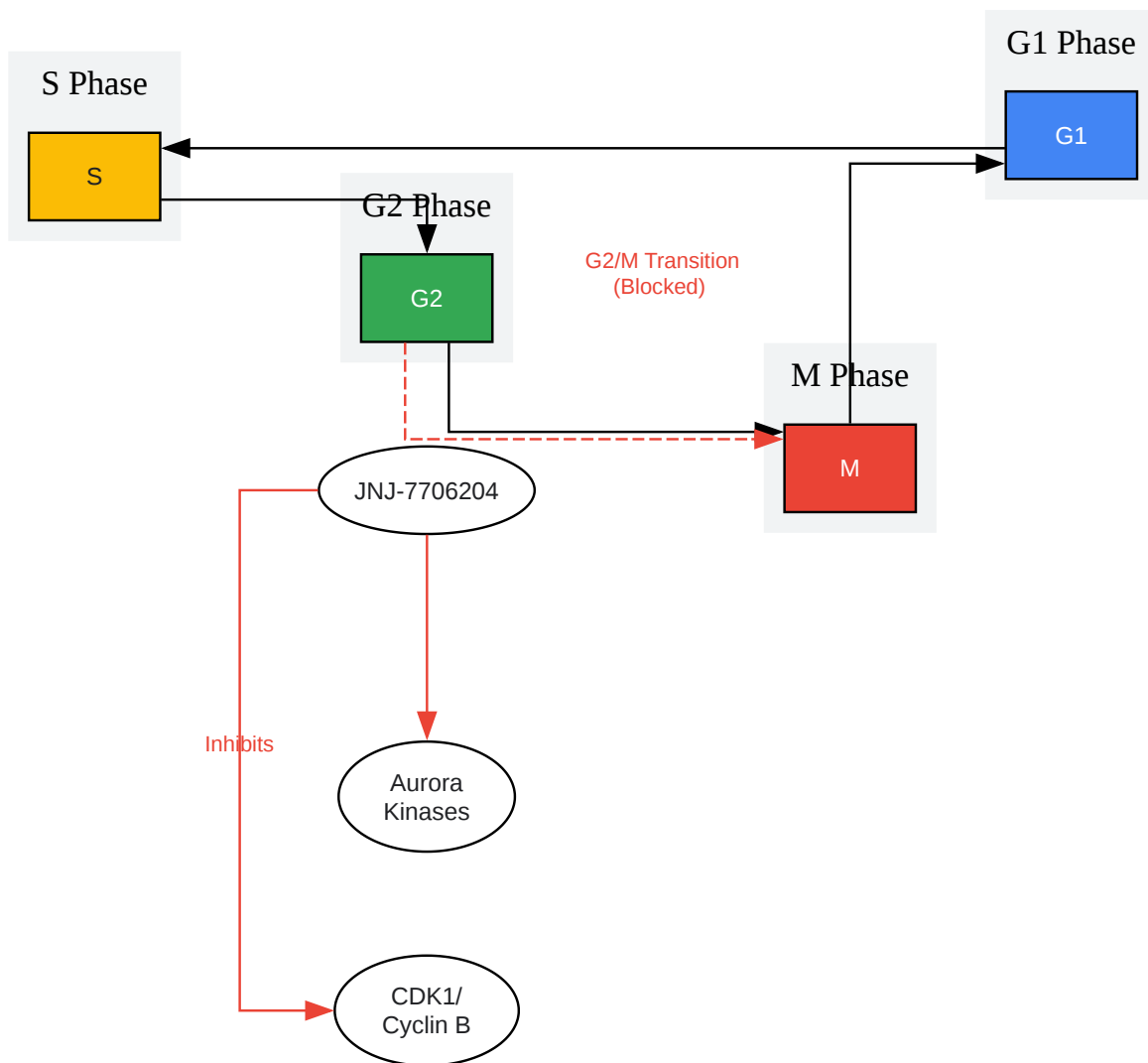

[Click to download full resolution via product page](#)

Caption: Mechanism of G2/M arrest by JNJ-7706204.

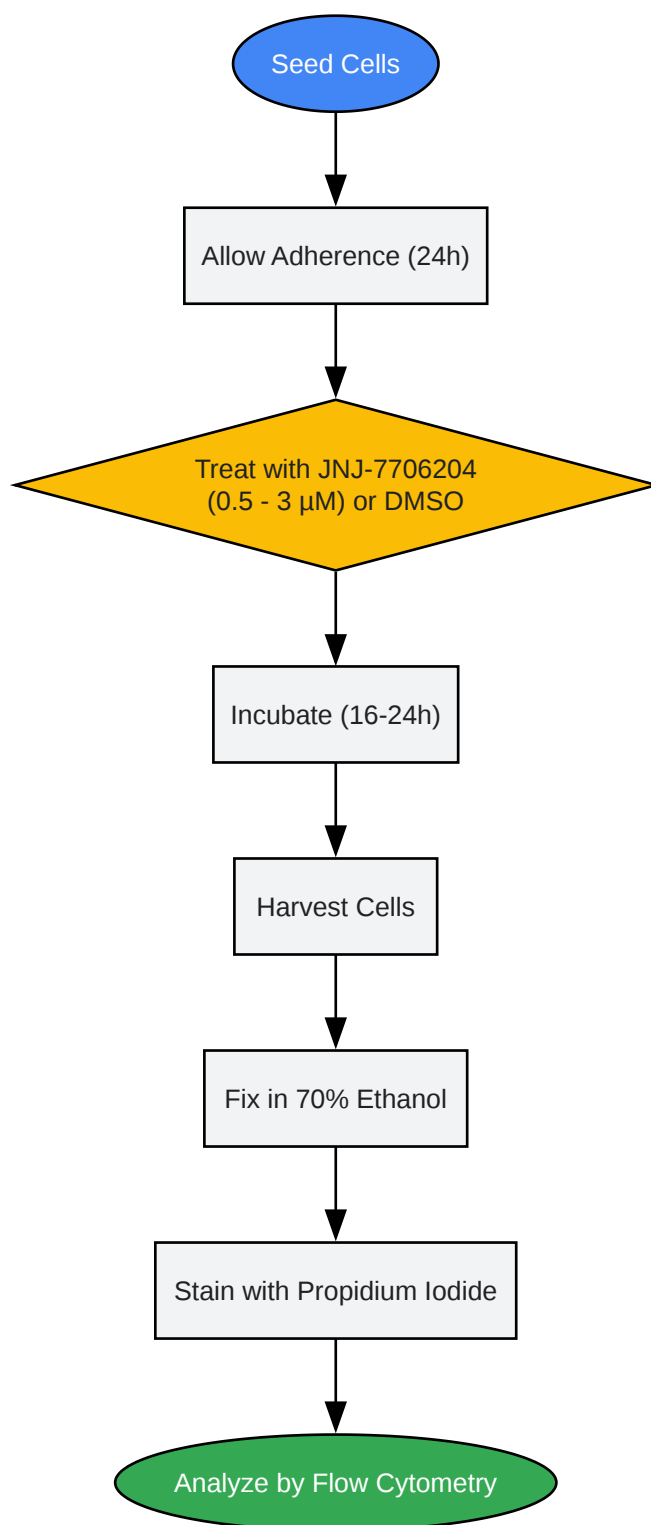

[Click to download full resolution via product page](#)

Caption: Experimental workflow for cell synchronization.

### Need Custom Synthesis?

BenchChem offers custom synthesis for rare earth carbides and specific isotopic labeling.

Email: [info@benchchem.com](mailto:info@benchchem.com) or [Request Quote Online](#).

## References

- [1. The in vitro and in vivo effects of JNJ-7706621: a dual inhibitor of cyclin-dependent kinases and aurora kinases - PubMed \[pubmed.ncbi.nlm.nih.gov\]](#)
- [2. apexbt.com \[apexbt.com\]](#)
- [3. researchgate.net \[researchgate.net\]](#)
- [4. selleckchem.com \[selleckchem.com\]](#)
- [5. medchemexpress.com \[medchemexpress.com\]](#)
- [6. Cdk1 activity is required for mitotic activation of aurora A during G2/M transition of human cells - PubMed \[pubmed.ncbi.nlm.nih.gov\]](#)
- [7. benchchem.com \[benchchem.com\]](#)
- To cite this document: BenchChem. [Application Notes and Protocols for JNJ-7706204 in Cell Synchronization Experiments]. BenchChem, [2026]. [Online PDF]. Available at: [\[https://www.benchchem.com/product/b15541541/docs#application-notes-and-protocols-for-jnj-7706204-in-cell-synchronization-experiments\]](https://www.benchchem.com/product/b15541541/docs#application-notes-and-protocols-for-jnj-7706204-in-cell-synchronization-experiments)

---

### Disclaimer & Data Validity:

The information provided in this document is for Research Use Only (RUO) and is strictly not intended for diagnostic or therapeutic procedures. While BenchChem strives to provide accurate protocols, we make no warranties, express or implied, regarding the fitness of this product for every specific experimental setup.

**Technical Support:** The protocols provided are for reference purposes. Unsure if this reagent suits your experiment?

**Need Industrial/Bulk Grade?** [Request Custom Synthesis Quote](#)

# BenchChem

Our mission is to be the trusted global source of essential and advanced chemicals, empowering scientists and researchers to drive progress in science and industry.

## Contact

Address: 3281 E Guasti Rd  
Ontario, CA 91761, United States  
Phone: (601) 213-4426  
Email: [info@benchchem.com](mailto:info@benchchem.com)

[Contact our Ph.D. Support Team for a compatibility check](#)