

# Application Notes and Protocols for Click Chemistry with PEGylated Azide Compounds

**Author:** BenchChem Technical Support Team. **Date:** May 2026

## Compound of Interest

Compound Name: Azide-PEG9-amido-C4-Boc

Cat. No.: B15541198

[Get Quote](#)

For Researchers, Scientists, and Drug Development Professionals

These application notes provide a comprehensive guide to performing click chemistry reactions with polyethylene glycol (PEG) functionalized with an azide group. The inclusion of a PEG linker can enhance the solubility, stability, and pharmacokinetic properties of the resulting conjugates, making this a valuable technique in drug development, bioconjugation, and materials science.<sup>[1][2][3]</sup> This document covers the two primary forms of azide-alkyne click chemistry: the Copper(I)-Catalyzed Azide-Alkyne Cycloaddition (CuAAC) and the Strain-Promoted Azide-Alkyne Cycloaddition (SPAAC).

## Copper(I)-Catalyzed Azide-Alkyne Cycloaddition (CuAAC) with PEGylated Azides

The CuAAC reaction is a highly efficient and reliable method for covalently linking molecules. It involves the reaction between a terminal alkyne and an azide, catalyzed by a copper(I) species, to form a stable 1,2,3-triazole linkage.<sup>[1][2][4]</sup>

### Advantages of CuAAC with PEGylated Azides:

- High Yields: The reaction is known for its high efficiency and quantitative conversion.<sup>[4][5]</sup>

- Mild Reaction Conditions: CuAAC can be performed in aqueous buffers and at room temperature, making it suitable for conjugating sensitive biomolecules.[1][4]
- Bioorthogonality: The azide and alkyne groups are generally absent in biological systems, ensuring specific labeling with minimal side reactions.[2][4]

## Data Presentation: Typical CuAAC Reaction Parameters

The following table summarizes typical reaction conditions for CuAAC involving PEGylated azides. The optimal conditions may vary depending on the specific substrates and desired outcome.

Parameter	Recommended Range	Notes
PEG-Azide	1.1 - 1.5 equivalents	A slight excess can improve reaction kinetics.[1]
Alkyne-functionalized molecule	1.0 equivalent	---
Copper(I) Source	0.01 - 0.1 equivalents	Can be Cu(I) salts (e.g., CuI, CuBr) or generated in situ from Cu(II) salts (e.g., CuSO <sub>4</sub> ) with a reducing agent.[1]
Reducing Agent (for Cu(II))	0.1 - 1.0 equivalents	Sodium ascorbate is commonly used to reduce Cu(II) to the active Cu(I) state. A fresh solution is crucial.[1]
Copper(I) Stabilizing Ligand	5 equivalents (relative to copper)	Ligands like THPTA or TBTA stabilize the Cu(I) catalyst, prevent oxidation, and can accelerate the reaction rate.[6][7]
Solvent	Aqueous buffers (e.g., PBS), organic solvents (e.g., DMF, DMSO), or mixtures	The choice of solvent depends on the solubility of the substrates.[1]
Reaction Temperature	Room temperature (25°C) or 37°C	The reaction is typically performed at room temperature.[1][4]
Reaction Time	1 - 4 hours	Reaction progress can be monitored by techniques like TLC, LC-MS, or HPLC.[1][4]

## Experimental Protocol: General Procedure for CuAAC with a PEGylated Azide

This protocol describes a general method for conjugating an alkyne-containing molecule to a PEGylated azide.

## Materials:

- Alkyne-functionalized molecule of interest
- Azide-PEG linker
- Copper(II) sulfate ( $\text{CuSO}_4$ )
- Sodium Ascorbate
- Tris(3-hydroxypropyltriazolylmethyl)amine (THPTA) or Tris[(1-benzyl-1H-1,2,3-triazol-4-yl)methyl]amine (TBTA)
- Reaction buffer (e.g., Phosphate-Buffered Saline - PBS, pH 7.4)
- Organic co-solvent if needed (e.g., DMSO, DMF)

## Procedure:

- Reagent Preparation:
  - Prepare a stock solution of the alkyne-functionalized molecule and the azide-PEG in the chosen reaction buffer. If solubility is an issue, a co-solvent like DMSO can be used.
  - Prepare a fresh stock solution of sodium ascorbate immediately before use.
  - Prepare a stock solution of  $\text{CuSO}_4$  and the stabilizing ligand (THPTA or TBTA).
- Reaction Setup:
  - In a reaction vessel, combine the alkyne-functionalized molecule (1 equivalent) and the azide-PEG (1.1-1.5 equivalents).<sup>[1]</sup>
  - Add the reaction buffer to achieve the desired final concentration.
  - Add the stabilizing ligand to the reaction mixture.
  - Add the  $\text{CuSO}_4$  solution to the reaction mixture to a final copper concentration of 50-250  $\mu\text{M}$ .<sup>[1]</sup>

- Initiate the reaction by adding the freshly prepared sodium ascorbate solution.
- Reaction and Monitoring:
  - Gently mix the reaction and incubate at room temperature for 1-4 hours.[1] The reaction can be performed on a rotator or shaker.
  - Monitor the reaction progress by an appropriate analytical method (e.g., LC-MS, HPLC, or SDS-PAGE for protein conjugations).
- Purification:
  - Once the reaction is complete, purify the PEGylated conjugate from excess reagents and catalyst using a suitable method such as size-exclusion chromatography, dialysis, or HPLC.

## Visualization: CuAAC Reaction and Workflow

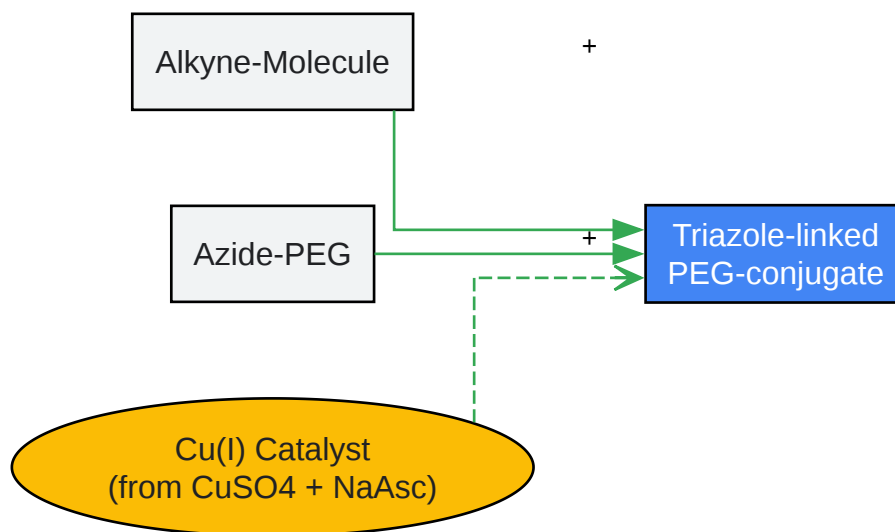

[Click to download full resolution via product page](#)

Caption: General scheme of the CuAAC reaction.

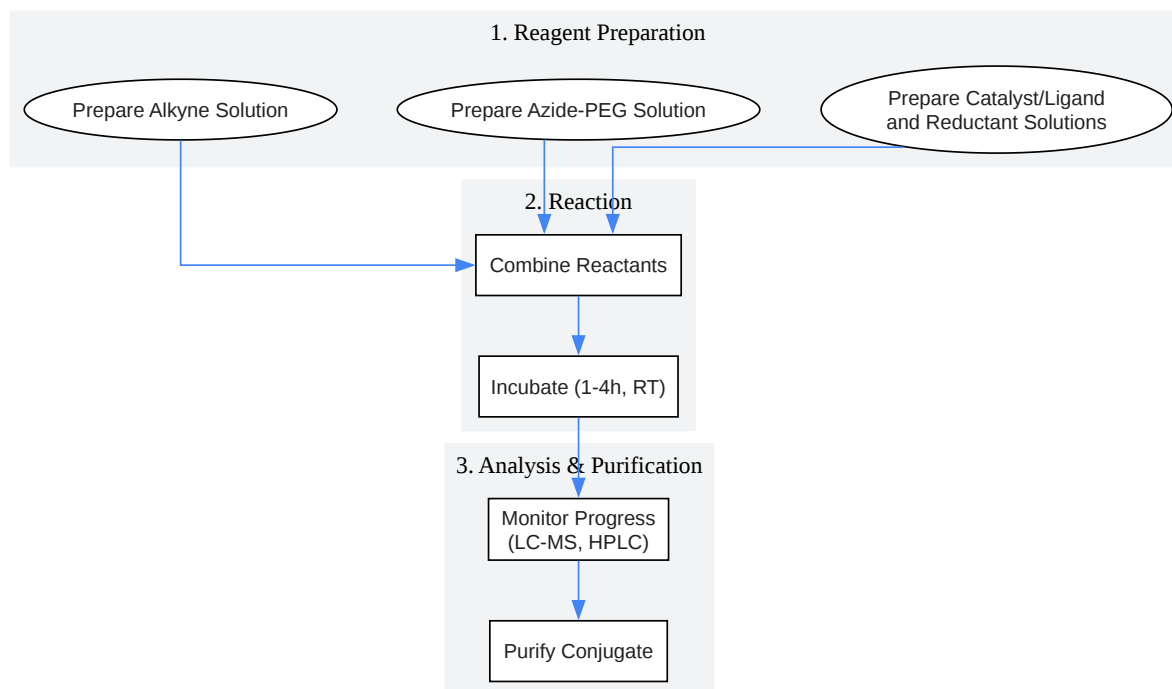

[Click to download full resolution via product page](#)

Caption: Experimental workflow for a typical CuAAC reaction.

## Strain-Promoted Azide-Alkyne Cycloaddition (SPAAC) with PEGylated Azides

SPAAC is a copper-free click chemistry reaction that utilizes a strained cyclooctyne (e.g., DBCO, BCN) which reacts spontaneously with an azide.<sup>[8][9]</sup> The absence of a cytotoxic copper catalyst makes SPAAC ideal for applications in living systems.<sup>[8][10]</sup>

### Advantages of SPAAC with PEGylated Azides:

- **Biocompatibility:** The copper-free nature of SPAAC makes it suitable for in vivo and live-cell applications.[8][10]
- **High Selectivity:** The strained alkyne and azide groups are bioorthogonal and do not react with other functional groups found in biological systems.[2]
- **Mild Conditions:** The reaction proceeds efficiently in aqueous buffers at physiological pH and temperature.[10][11]

## Data Presentation: SPAAC Reaction Parameters and Kinetics

The rate of a SPAAC reaction is dependent on the choice of the strained alkyne. The following table provides a summary of typical reaction conditions and second-order rate constants for common cyclooctynes.

Strained Alkyne	Second-Order Rate Constant ( $k_2$ ) with Benzyl Azide ( $M^{-1}s^{-1}$ )	Typical Molar Excess of Azide-PEG	Reaction Time
DBCO (Dibenzocyclooctyne)	~0.1[12]	10-20 fold[8]	4-12 hours[13]
BCN (Bicyclo[6.1.0]nonyne)	0.14[12]	10-20 fold	4-12 hours
DIBO (Dibenzocyclooctynol)	0.17[12]	10-20 fold	4-12 hours

Note: The rate constants provided are for benzyl azide and serve as a reference; the reactivity of a PEGylated azide is expected to be in a similar range. The inclusion of a PEG linker can increase reaction rates.[12][14]

## Experimental Protocol: General Procedure for SPAAC with a PEGylated Azide

This protocol describes a general method for conjugating a strained alkyne-containing molecule to a PEGylated azide.

#### Materials:

- Strained alkyne (e.g., DBCO, BCN)-functionalized molecule of interest
- Azide-PEG linker
- Reaction Buffer (e.g., Phosphate-Buffered Saline - PBS, pH 7.4, or other amine-free buffer)
- Organic Solvent (if needed for dissolution, e.g., DMSO or DMF)

#### Procedure:

- Reagent Preparation:
  - Prepare a stock solution of the strained alkyne-functionalized molecule in the reaction buffer.
  - Prepare a stock solution of the Azide-PEG linker in a suitable solvent (e.g., DMSO or the reaction buffer).
- Reaction Setup:
  - In a reaction vessel, add the solution of the strained alkyne-functionalized molecule.
  - Add the desired molar excess of the Azide-PEG stock solution to the reaction mixture. A 10-20 fold molar excess of the azide is a common starting point.[\[8\]](#)
- Incubation:
  - Gently mix the reaction components and incubate at room temperature (25°C) for 4-12 hours or at 4°C for 12-24 hours.[\[13\]](#) The optimal time may need to be determined empirically.
- Purification:

- Purify the PEGylated conjugate from excess unreacted azide-PEG using a suitable method such as spin desalting columns, HPLC, or FPLC.

## Visualization: SPAAC Reaction and Workflow

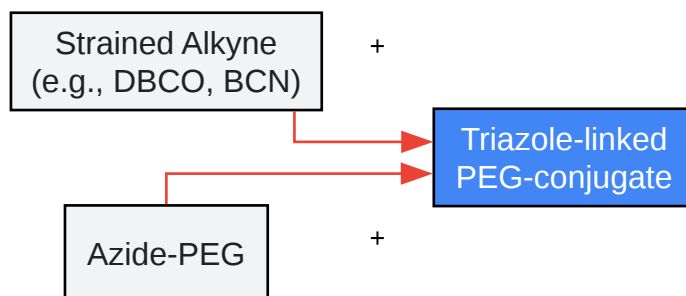

[Click to download full resolution via product page](#)

Caption: General scheme of the SPAAC reaction.

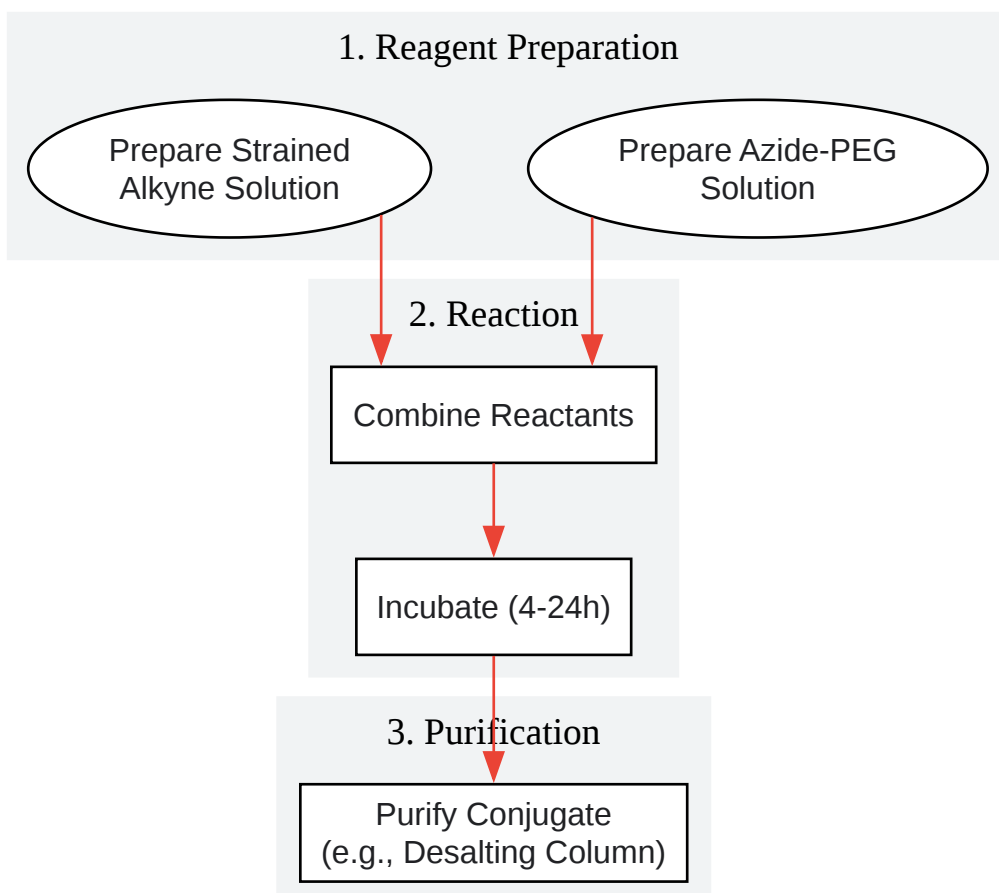

[Click to download full resolution via product page](#)

Caption: Experimental workflow for a typical SPAAC reaction.

### Need Custom Synthesis?

BenchChem offers custom synthesis for rare earth carbides and specific isotopic labeling.

Email: [info@benchchem.com](mailto:info@benchchem.com) or [Request Quote Online](#).

## References

- [1. benchchem.com \[benchchem.com\]](#)
- [2. benchchem.com \[benchchem.com\]](#)
- [3. 點擊化學試劑概述 \[sigmaaldrich.com\]](#)
- [4. glenresearch.com \[glenresearch.com\]](#)
- [5. Click Chemistry \[organic-chemistry.org\]](#)
- [6. benchchem.com \[benchchem.com\]](#)
- [7. jenabioscience.com \[jenabioscience.com\]](#)
- [8. benchchem.com \[benchchem.com\]](#)
- [9. Strain-Promoted Azide-Alkyne Cycloaddition \[manu56.magtech.com.cn\]](#)
- [10. vectorlabs.com \[vectorlabs.com\]](#)
- [11. benchchem.com \[benchchem.com\]](#)
- [12. benchchem.com \[benchchem.com\]](#)
- [13. benchchem.com \[benchchem.com\]](#)
- [14. The effects of buffer, pH, and temperature upon SPAAC reaction rates - Organic & Biomolecular Chemistry \(RSC Publishing\) \[pubs.rsc.org\]](#)
- To cite this document: BenchChem. [Application Notes and Protocols for Click Chemistry with PEGylated Azide Compounds]. BenchChem, [2026]. [Online PDF]. Available at: [\[https://www.benchchem.com/product/b15541198/docs#application-notes-and-protocols-for-click-chemistry-with-pegylated-azide-compounds\]](https://www.benchchem.com/product/b15541198/docs#application-notes-and-protocols-for-click-chemistry-with-pegylated-azide-compounds)

---

### Disclaimer & Data Validity:

The information provided in this document is for Research Use Only (RUO) and is strictly not intended for diagnostic or therapeutic procedures. While BenchChem strives to provide accurate protocols, we make no warranties, express or implied, regarding the fitness of this product for every specific experimental setup.

**Technical Support:** The protocols provided are for reference purposes. Unsure if this reagent suits your experiment?

**Need Industrial/Bulk Grade?** [Request Custom Synthesis Quote](#)

## BenchChem

Our mission is to be the trusted global source of essential and advanced chemicals, empowering scientists and researchers to drive progress in science and industry.

### Contact

Address: 3281 E Guasti Rd  
Ontario, CA 91761, United States  
Phone: (601) 213-4426  
Email: [info@benchchem.com](mailto:info@benchchem.com)

[Contact our Ph.D. Support Team for a compatibility check](#)