

Application Notes: SSTC3 for High-Throughput Screening of Wnt Pathway Inhibitors

Author: BenchChem Technical Support Team. **Date:** April 2026

Compound of Interest

Compound Name: SSTC3
Cat. No.: B15541654

[Get Quote](#)

Introduction

The canonical Wnt/ β -catenin signaling pathway is a fundamental regulator of cellular processes, including proliferation, differentiation, and tissue homeostasis.[1][2] Aberrant activation of this pathway, often due to mutations in components like Adenomatous Polyposis Coli (APC) or β -catenin, is a primary driver in numerous cancers, particularly colorectal cancer (CRC).[3][4] Consequently, the Wnt pathway is a significant target for therapeutic intervention. However, the development of effective Wnt inhibitors has been challenging, partly due to on-target toxicities in normal tissues.[1][5]

SSTC3 is a novel, potent, and specific small-molecule activator of Casein Kinase 1 α (CK1 α), a critical negative regulator within the β -catenin destruction complex.[3][6] By allosterically activating CK1 α , **SSTC3** enhances the degradation of β -catenin, thereby inhibiting Wnt signaling.[1][7] Its well-characterized mechanism, high potency, and improved pharmacokinetic profile compared to other CK1 α activators make it an ideal tool compound and positive control for high-throughput screening (HTS) campaigns aimed at discovering novel Wnt pathway inhibitors.[6][8]

Mechanism of Action of **SSTC3**

In the absence of a Wnt ligand (the "off-state"), a cytoplasmic "destruction complex" comprising Axin, APC, Glycogen Synthase Kinase 3 β (GSK3 β), and CK1 α phosphorylates β -catenin.[1][2] This phosphorylation marks β -catenin for ubiquitination and subsequent proteasomal degradation, keeping its cytoplasmic levels low.[1][9]

Upon Wnt ligand binding to its Frizzled (FZD) and LRP5/6 co-receptors (the "on-state"), the destruction complex is inactivated.[1] This allows β -catenin to stabilize, accumulate in the cytoplasm, and translocate to the nucleus. There, it partners with T-cell factor/lymphoid enhancer-factor (TCF/LEF) transcription factors to activate the expression of Wnt target genes that drive cell proliferation.[1][7]

SSTC3 functions by directly binding to and activating CK1 α . [6][9] This enhancement of CK1 α 's kinase activity potentiates the function of the destruction complex, leading to robust phosphorylation and degradation of β -catenin, effectively overriding the "on-state" signal and inhibiting the transcription of Wnt target genes.[7][10]

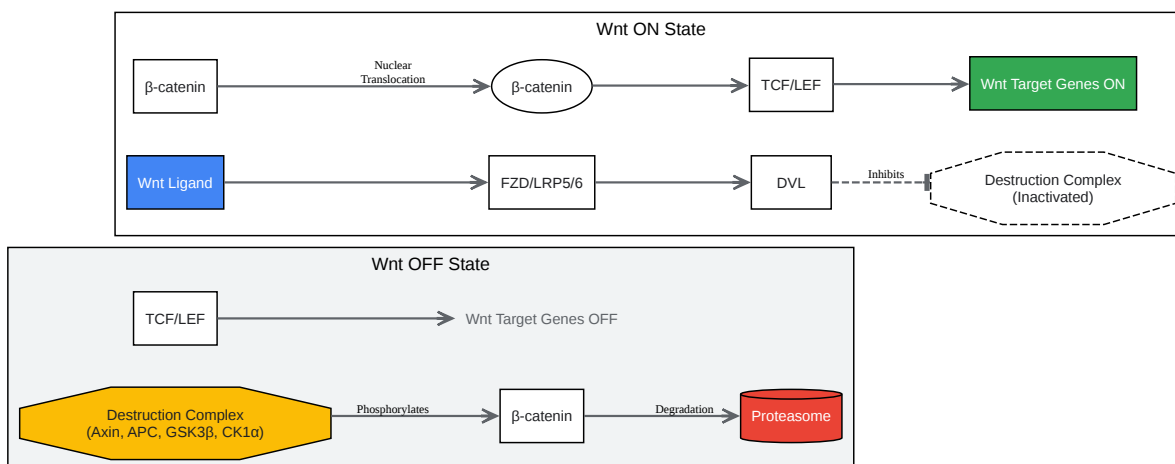

[Click to download full resolution via product page](#)

Caption: Canonical Wnt/ β -catenin signaling pathway in the "OFF" and "ON" states.

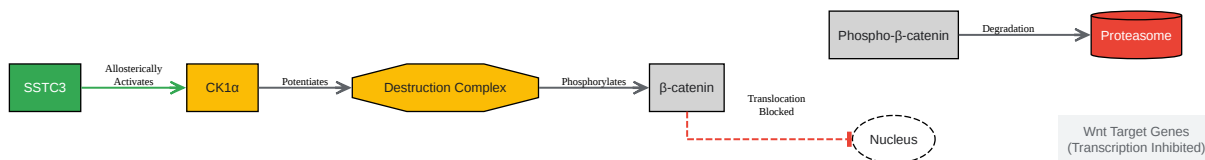

[Click to download full resolution via product page](#)

Caption: **SSTC3** activates CK1 α to promote β -catenin degradation and inhibit Wnt signaling.

Quantitative Data Presentation

SSTC3 demonstrates high potency and selectivity in both biochemical and cell-based assays.

Table 1: In Vitro Potency and Selectivity of **SSTC3**

Parameter	Value	Description	Reference
Binding Affinity (Kd) for CK1 α	32 nM	Dissociation constant for SSTC3 binding to purified recombinant CK1α, determined by surface plasmon resonance (SPR).	[3] [6]
Wnt Signaling Inhibition (EC50)	30 nM	Half-maximal effective concentration for inhibiting a Wnt-driven reporter gene in HEK293T cells.	[6] [11]
Cell Viability Inhibition (EC50)	78 nM	EC50 for decreasing viability in HCT116 CRC cells (mutant CTNNB1 allele).	[6]
Cell Viability Inhibition (EC50)	1.5 μ M	EC50 for decreasing viability in HCT116 CRC cells (mutant CTNNB1 allele deleted).	[6]
Organoid Growth Inhibition (EC50)	70 nM	EC50 for attenuating the growth of Apcmin mutant organoids.	[6]

| Organoid Growth Inhibition (EC50) | 2.9 μ M | EC50 for attenuating the growth of wild-type organoids. [\[\[6\]](#) |

Table 2: In Vivo Efficacy of **SSTC3** in Mouse Models

Animal Model	Dosing Regimen	Outcome	Reference
CD-1 mice with HCT116 xenografts	25 mg/kg, i.p. daily for 8-12 days	Suppressed tumor growth.	[10][11]
Apcmin mice	10 mg/kg, i.p. daily for 1 month	Inhibited Apc mutation-driven tumor growth; reduced polyp number and size.	[6][11]

| Patient-derived metastatic CRC xenograft | Not specified | Attenuated tumor growth. |[6][10] |

High-Throughput Screening (HTS) Application

A common HTS strategy for discovering Wnt pathway modulators is the use of a reporter gene assay.[4][12] The TCF/LEF-driven luciferase reporter assay (e.g., TOPflash) is a robust and widely used method.[13][14] In this setup, **SSTC3** serves as a highly effective positive control to validate assay performance and quantify the inhibitory potential of screening hits.

The workflow involves seeding cells stably expressing the reporter system, stimulating the Wnt pathway (e.g., with Wnt3a conditioned media or a GSK3 β inhibitor like CHIR99021), and then treating with library compounds.[13][15] The reduction in luciferase signal indicates potential Wnt pathway inhibition.

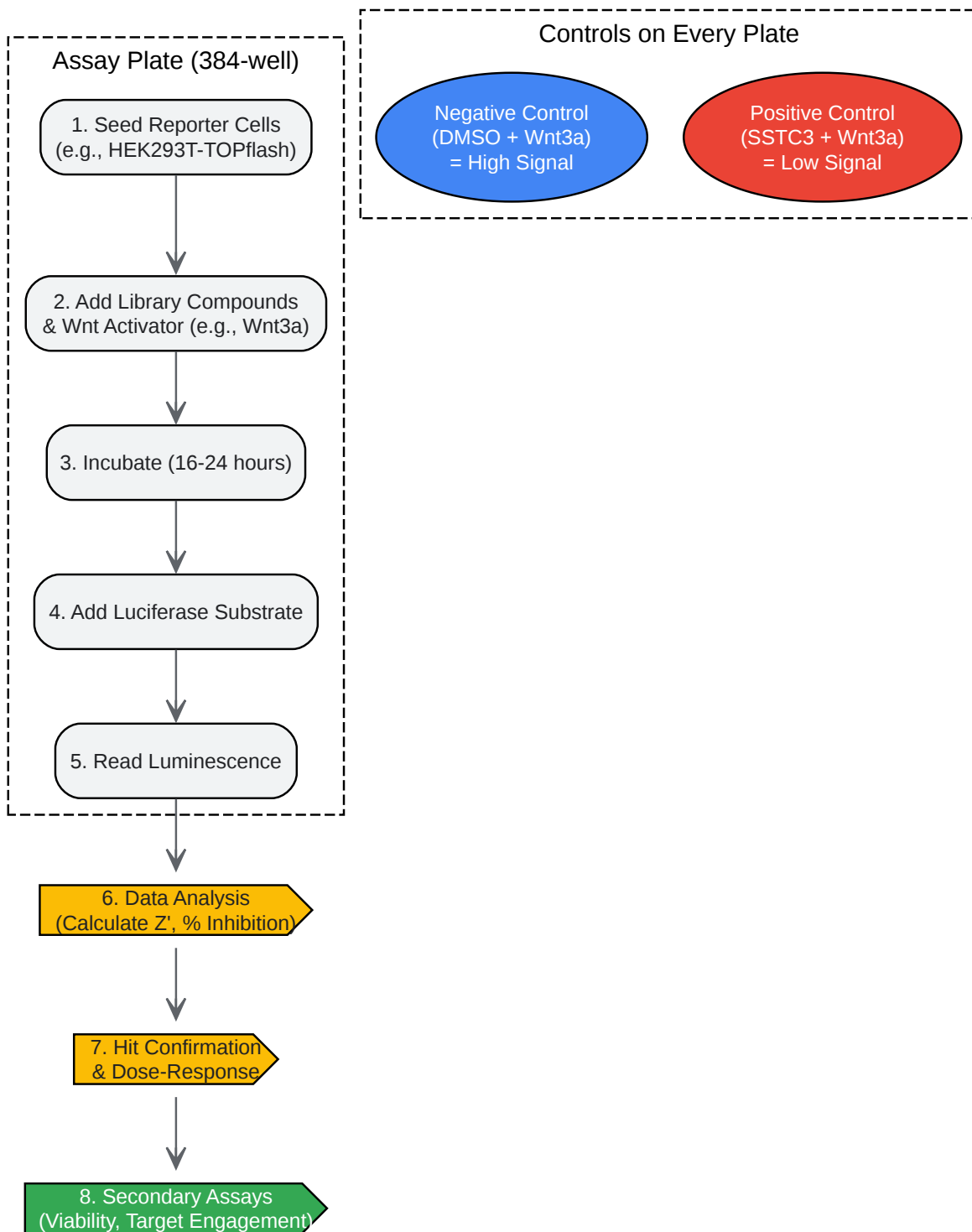

[Click to download full resolution via product page](#)

Caption: High-throughput screening workflow for identifying Wnt signaling inhibitors.

Experimental Protocols

Protocol 1: Wnt Reporter Gene Assay (TOPflash)

This assay quantifies the activity of the canonical Wnt pathway and is the primary screen for inhibitors.[\[8\]](#)[\[10\]](#)

Materials:

- HEK293T cells (or other suitable cell line)
- DMEM with 10% FBS and 1% Penicillin-Streptomycin
- TCF/LEF-Firefly luciferase reporter plasmid (e.g., M50 Super 8x TOPFlash)
- Renilla luciferase control plasmid (e.g., pRL-TK) for normalization
- Transfection reagent (e.g., TransIT-LT1)
- Wnt3a conditioned media or recombinant Wnt3a
- **SSTC3** (for positive control)
- 96-well or 384-well white, clear-bottom plates
- Dual-Luciferase® Reporter Assay System
- Luminometer

Procedure:

- Cell Seeding: Seed 2×10^4 HEK293T cells per well in a 96-well plate. Allow cells to adhere overnight.[\[1\]](#)
- Transfection: Co-transfect cells with 100 ng of TOPflash reporter plasmid and 10 ng of pRL-TK control plasmid per well using a suitable transfection reagent according to the manufacturer's instructions.[\[1\]](#)[\[14\]](#)
- Incubation: Incubate cells for 24 hours post-transfection.[\[10\]](#)

- Treatment: Replace the medium with fresh medium containing the Wnt pathway activator (e.g., Wnt3a conditioned media) and serial dilutions of test compounds or **SSTC3** (e.g., 1 nM to 10 μ M). Include appropriate vehicle controls (e.g., DMSO).[14]
- Final Incubation: Incubate the cells for another 16-24 hours.[10]
- Cell Lysis: Aspirate the media and lyse the cells by adding 20 μ L of 1X Passive Lysis Buffer per well. Incubate for 15 minutes at room temperature on an orbital shaker.[13]
- Luminometry: Measure Firefly and Renilla luciferase activities sequentially using a luminometer according to the Dual-Luciferase® Reporter Assay System protocol.[13]
- Data Analysis: Normalize the Firefly luciferase activity to the Renilla luciferase activity for each well. Plot the normalized luciferase activity against the compound concentration to determine the EC50.[1]

Protocol 2: Cell Viability Assay

This secondary assay is used to assess the effect of confirmed hits on the proliferation of Wnt-dependent cancer cells.[10][16]

Materials:

- Colorectal cancer cell lines (e.g., HCT116, SW403)
- 96-well cell culture plates
- Complete cell culture medium
- **SSTC3** and confirmed hit compounds
- CellTiter-Glo® Luminescent Cell Viability Assay or MTT reagent
- Microplate reader (Luminometer or Spectrophotometer)

Procedure:

- Cell Seeding: Seed 3,000-5,000 CRC cells per well in a 96-well plate. Allow cells to attach overnight.[16]
- Treatment: Treat cells with a range of concentrations of the test compound or **SSTC3**.[10]
- Incubation: Incubate the cells for 5 days, as the effects on viability may take longer to manifest.[10][11]
- Viability Assessment: Assess cell viability using a commercial assay like CellTiter-Glo® (quantifies ATP) or MTT (measures metabolic activity) according to the manufacturer's instructions.[10]
- Data Analysis: Normalize the signal to vehicle-treated controls and plot against compound concentration to determine the EC50 for cell viability.

Protocol 3: Western Blot for β -Catenin Phosphorylation

This assay helps confirm if an inhibitor acts through a mechanism similar to **SSTC3** by promoting β -catenin degradation.

Materials:

- SW403 or other Wnt-sensitive cell line
- **SSTC3** and confirmed hit compounds
- RIPA lysis buffer with protease and phosphatase inhibitors
- Primary antibodies: anti-phospho- β -catenin, anti-total- β -catenin, anti-GAPDH (loading control)
- HRP-conjugated secondary antibodies
- SDS-PAGE gels and Western blotting reagents and equipment

Procedure:

- Cell Treatment: Plate cells and allow them to adhere. Treat with the compound (e.g., 100 nM **SSTC3**) or vehicle for a short duration (e.g., 15 minutes) to observe acute phosphorylation events.[9][11]
- Cell Lysis: Wash cells with ice-cold PBS and lyse with RIPA buffer.[9]
- Protein Quantification: Determine the protein concentration of each lysate using a BCA assay.[9]
- SDS-PAGE and Transfer: Load equal amounts of protein onto an SDS-PAGE gel, separate the proteins by electrophoresis, and transfer them to a PVDF membrane.[16]
- Immunoblotting:
 - Block the membrane with 5% BSA in TBST for 1 hour.[9]
 - Incubate the membrane with the primary antibody (e.g., anti-phospho- β -catenin) overnight at 4°C.[9]
 - Wash and incubate with an HRP-conjugated secondary antibody for 1 hour.[16]
- Detection: Apply a chemiluminescent substrate and visualize the protein bands using an imaging system. Re-probe the membrane for total β -catenin and a loading control.[16]
- Data Analysis: Quantify band intensities to determine the ratio of phosphorylated to total β -catenin. An increase in this ratio indicates a mechanism consistent with destruction complex activation.

Need Custom Synthesis?

BenchChem offers custom synthesis for rare earth carbides and specific isotopic labeling.

Email: info@benchchem.com or [Request Quote Online](#).

References

- 1. [benchchem.com](https://www.benchchem.com) [benchchem.com]

- 2. Advances in the development of Wnt/ β -catenin signaling inhibitors - PMC [[pmc.ncbi.nlm.nih.gov](https://pubmed.ncbi.nlm.nih.gov)]
- 3. [benchchem.com](https://www.benchchem.com) [[benchchem.com](https://www.benchchem.com)]
- 4. A Cell Model Suitable for a High-Throughput Screening of Inhibitors of the Wnt/ β -Catenin Pathway - PMC [[pmc.ncbi.nlm.nih.gov](https://pubmed.ncbi.nlm.nih.gov)]
- 5. Differential abundance of CK1 α provides selectivity for pharmacological CK1 α activators to target WNT-dependent tumors - PubMed [pubmed.ncbi.nlm.nih.gov]
- 6. Differential abundance of CK1 α provides selectivity for pharmacological CK1 α activators to target WNT-dependent tumors - PMC [[pmc.ncbi.nlm.nih.gov](https://pubmed.ncbi.nlm.nih.gov)]
- 7. [benchchem.com](https://www.benchchem.com) [[benchchem.com](https://www.benchchem.com)]
- 8. [benchchem.com](https://www.benchchem.com) [[benchchem.com](https://www.benchchem.com)]
- 9. [benchchem.com](https://www.benchchem.com) [[benchchem.com](https://www.benchchem.com)]
- 10. [benchchem.com](https://www.benchchem.com) [[benchchem.com](https://www.benchchem.com)]
- 11. [medchemexpress.com](https://www.medchemexpress.com) [[medchemexpress.com](https://www.medchemexpress.com)]
- 12. A high-throughput screen for Wnt/ β -catenin signaling pathway modulators in human iPSC-derived neural progenitors - PubMed [pubmed.ncbi.nlm.nih.gov]
- 13. [benchchem.com](https://www.benchchem.com) [[benchchem.com](https://www.benchchem.com)]
- 14. [benchchem.com](https://www.benchchem.com) [[benchchem.com](https://www.benchchem.com)]
- 15. [researchgate.net](https://www.researchgate.net) [[researchgate.net](https://www.researchgate.net)]
- 16. [benchchem.com](https://www.benchchem.com) [[benchchem.com](https://www.benchchem.com)]
- To cite this document: BenchChem. [Application Notes: SSTC3 for High-Throughput Screening of Wnt Pathway Inhibitors]. BenchChem, [2026]. [Online PDF]. Available at: [<https://www.benchchem.com/product/b15541654/docs#application-notes-sstc3-for-high-throughput-screening-of-wnt-pathway-inhibitors>]

Disclaimer & Data Validity:

The information provided in this document is for Research Use Only (RUO) and is strictly not intended for diagnostic or therapeutic procedures. While BenchChem strives to provide accurate protocols, we make no warranties, express or implied, regarding the fitness of this product for every specific experimental setup.

Technical Support: The protocols provided are for reference purposes. Unsure if this reagent suits your experiment?

Need Industrial/Bulk Grade? [Request Custom Synthesis Quote](#)

BenchChem

Our mission is to be the trusted global source of essential and advanced chemicals, empowering scientists and researchers to drive progress in science and industry.

Contact

Address: 3281 E Guasti Rd
Ontario, CA 91761, United States
Phone: (601) 213-4426
Email: info@benchchem.com

[Contact our Ph.D. Support Team for a compatibility check](#)