

A Technical Guide to Studying Neuroinflammation with PLX5622

Author: BenchChem Technical Support Team. **Date:** April 2026

Compound of Interest

Compound Name: *PLX5622 hemifumarate*

Cat. No.: *B15541549*

[Get Quote](#)

For Researchers, Scientists, and Drug Development Professionals

This guide provides an in-depth overview of PLX5622, a potent and selective colony-stimulating factor 1 receptor (CSF1R) inhibitor, as a critical tool for investigating the role of microglia in neuroinflammation. By inducing the depletion of microglia, PLX5622 offers a unique opportunity to dissect the complex functions of these resident immune cells of the central nervous system (CNS) in both health and disease.

Mechanism of Action: Targeting Microglial Survival

PLX5622 is a brain-penetrant small molecule that exhibits high selectivity for the CSF1R, a receptor tyrosine kinase essential for the survival, proliferation, and differentiation of microglia and other myeloid cells.[1][2][3] By binding to the ATP-binding site of CSF1R, PLX5622 inhibits its downstream signaling pathways, ultimately leading to apoptosis and the elimination of microglia from the CNS.[4]

CSF1R Signaling Pathway and PLX5622 Inhibition

The binding of CSF1R ligands, CSF1 and IL-34, activates downstream signaling cascades crucial for microglial function. PLX5622 competitively inhibits this activation.

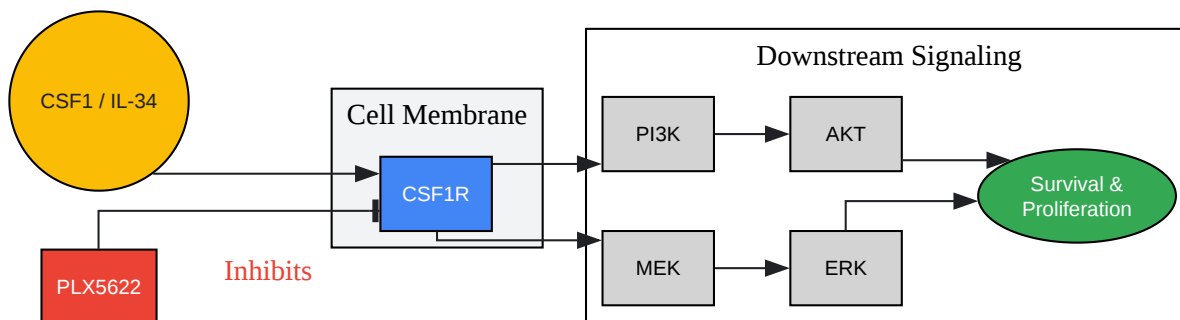

[Click to download full resolution via product page](#)

CSF1R signaling pathway and the inhibitory action of PLX5622.

Quantitative Data on PLX5622 Efficacy

The efficiency of microglial depletion with PLX5622 is dose- and duration-dependent. A standard dose of 1200 ppm formulated in rodent chow is widely used to achieve robust depletion.

Table 1: Microglial Depletion Efficiency with PLX5622

Brain Region	Treatment Duration	Depletion Percentage	Reference
Whole Brain	3 days	~80%	[2]
Whole Brain	7 days	~95%	[5][6]
Hypothalamus	7 days	~98%	[7]
Whole Brain	21 days	>99%	[2]
Cortex (Aged Mice)	21 days	Significant reduction	[8]
Striatum (Aged Mice)	21 days	Significant reduction	[8]

Table 2: Effects of PLX5622 in Neuroinflammatory Models

Disease Model	PLX5622 Dose	Key Findings	Reference
Experimental Autoimmune Encephalomyelitis (EAE)	1200 ppm in chow	Ameliorated EAE symptoms, reduced demyelination and immune activation.	[9]
Alzheimer's Disease (3xTg-AD)	1200 ppm in chow	Improved learning and memory.	[10]
Alzheimer's Disease (5xFAD)	1200 ppm in chow	Reduced plaque-associated microglia and NLRP3 inflammasome complexes.	[11]
Traumatic Brain Injury (TBI)	1200 ppm in chow	Reduced cortical lesion size and hippocampal neuron death.	[6][12]
Sepsis-Associated Encephalopathy	300 ppm in chow	Attenuated long-term neurocognitive dysfunction.	[1][13]
West Nile Virus Encephalitis	1200 ppm in chow	Reduced infiltration of inflammatory monocytes.	[10]
Neuropathic Pain (PSNL model)	65 mg/kg oral gavage	Reduced microglia density in the spinal cord and alleviated pain behavior.	[10][14]

Experimental Protocols

Administration of PLX5622

The most common and non-invasive method for PLX5622 administration is through formulated rodent chow.[10]

Protocol for Oral Administration via Formulated Chow:

- Materials: PLX5622-formulated rodent chow (e.g., 1200 ppm in AIN-76A), control chow (AIN-76A without PLX5622), experimental animals.[10]
- Acclimatization: House animals with ad libitum access to standard chow and water.
- Treatment: Replace standard chow with PLX5622-formulated chow for the treatment group and control chow for the control group.[10]
- Monitoring: Regularly monitor the health and body weight of the animals.
- Duration: Continue treatment for the desired period (e.g., 7-21 days for depletion).
- Tissue Collection: Proceed with tissue collection for analysis at the end of the treatment period.

Alternative Administration Methods:

- Oral Gavage: Allows for precise daily dosing. A typical dose is 65 mg/kg body weight.[10][14]
- Intraperitoneal (IP) Injection: Can also be used for precise dosing, for example, at 50 mg/kg. [2][10]

Verification of Microglial Depletion

It is crucial to verify the extent of microglial depletion in each experiment. This is typically achieved through immunohistochemistry (IHC) or flow cytometry.

Protocol for Verification by Immunohistochemistry:

- Tissue Processing: Perfuse animals with phosphate-buffered saline (PBS) followed by 4% paraformaldehyde (PFA).[10] Post-fix the brain tissue in 4% PFA and then transfer to a sucrose solution for cryoprotection.
- Sectioning: Section the brain tissue using a cryostat or vibratome.
- Staining:

- Perform antigen retrieval if necessary.[15]
- Block non-specific binding with a blocking solution (e.g., 3% Normal Goat Serum in 0.5% Triton X-100 in PBS).[16]
- Incubate with a primary antibody against a microglial marker, such as Iba1 or P2Y12.[10][15][16]
- Incubate with an appropriate fluorescently labeled secondary antibody.[10]
- Counterstain with a nuclear marker like DAPI.[10]
- Analysis: Image the stained sections using a confocal or fluorescence microscope. Quantify the number of Iba1-positive or P2Y12-positive cells in specific brain regions and compare between PLX5622-treated and control groups.[10]

Protocol for Verification by Flow Cytometry:

- Tissue Processing: Isolate brains and mechanically and/or enzymatically dissociate the tissue to create a single-cell suspension.
- Myelin Removal: Remove myelin debris, often using a Percoll gradient.[17]
- Staining:
 - Stain the single-cell suspension with fluorescently-conjugated antibodies against microglial surface markers (e.g., CD11b and CD45). Microglia are typically identified as the CD11b⁺/CD45^{int} population.[6][18]
 - Include a viability dye to exclude dead cells.[10]
- Analysis: Acquire the samples on a flow cytometer. Gate on the live, single-cell population and then identify and quantify the microglia population based on marker expression.[17]

Experimental Workflow Example

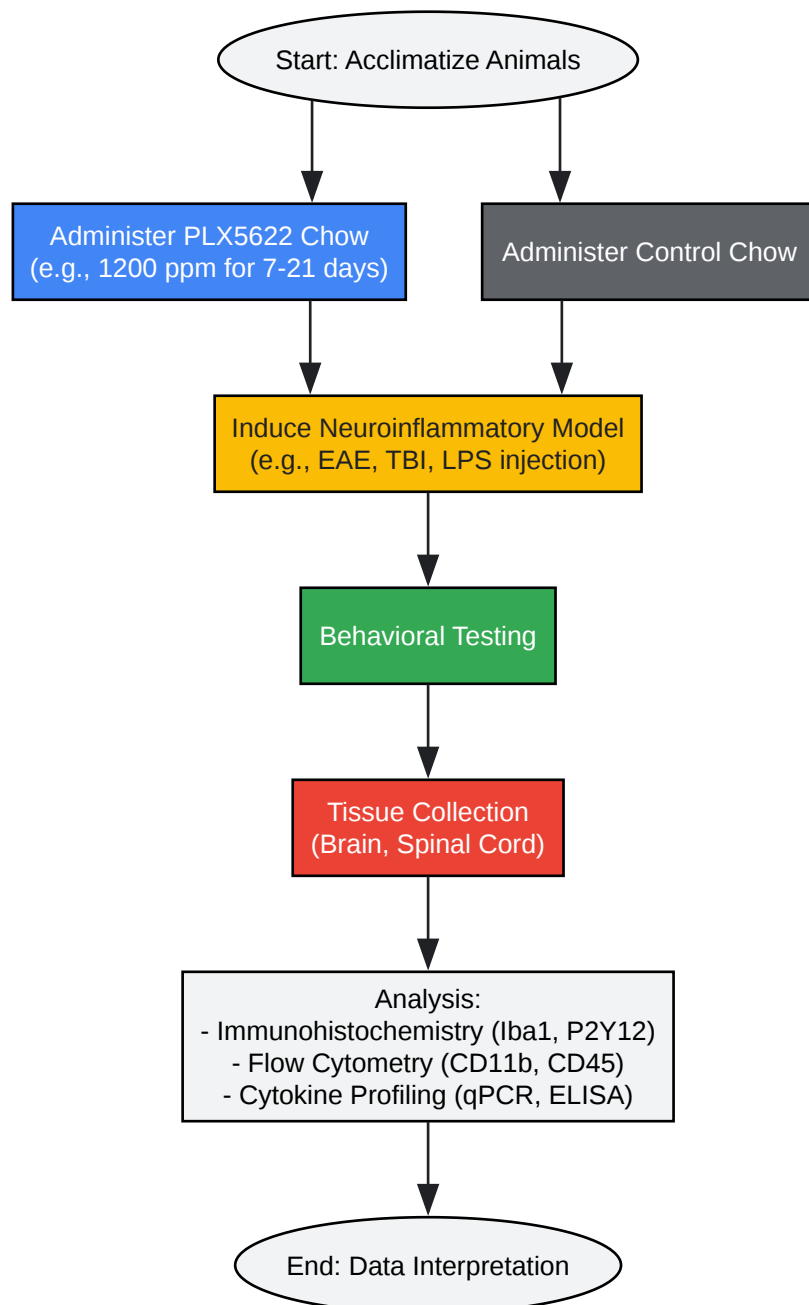

[Click to download full resolution via product page](#)

A generalized experimental workflow for using PLX5622.

Important Considerations

- **Off-Target Effects:** While PLX5622 is highly selective for CSF1R, researchers should be aware of potential off-target effects. Some studies suggest that PLX5622 can impact peripheral myeloid populations, such as bone marrow monocytes, and may influence the

metabolism of other drugs.[19][20][21][22] Therefore, interpreting data solely as a consequence of microglial depletion should be done with caution.[22]

- **Microglial Repopulation:** A key feature of PLX5622 treatment is the rapid repopulation of the microglial niche upon withdrawal of the drug.[10] This repopulation is typically complete within 7 to 14 days and offers a valuable model for studying the function of newly differentiated microglia.[5][10][23]
- **Model-Specific Effects:** The impact of microglial depletion can vary significantly depending on the specific neuroinflammatory model being studied. For instance, in some models of viral encephalitis, microglial depletion can be protective, while in others, it may exacerbate the disease.[24]

Conclusion

PLX5622 is a powerful and indispensable tool for investigating the multifaceted roles of microglia in neuroinflammation.[10] Its ability to efficiently and reversibly deplete microglia provides a unique opportunity to elucidate the complex functions of these cells in both the healthy and diseased CNS. By implementing carefully designed experiments with appropriate controls and giving due consideration to potential off-target effects, researchers can effectively leverage PLX5622 to gain profound insights into the pathophysiology of neuroinflammatory disorders and to explore the therapeutic potential of targeting microglia.

Need Custom Synthesis?

BenchChem offers custom synthesis for rare earth carbides and specific isotopic labeling.

Email: info@benchchem.com or [Request Quote Online](#).

References

- [1. Low-dose PLX5622 treatment prevents neuroinflammatory and neurocognitive sequelae after sepsis - PMC \[pmc.ncbi.nlm.nih.gov\]](#)
- [2. file.medchemexpress.com \[file.medchemexpress.com\]](#)
- [3. discovery.researcher.life \[discovery.researcher.life\]](#)
- [4. researchgate.net \[researchgate.net\]](#)

- [5. Microglial Depletion with CSF1R Inhibitor During Chronic Phase of Experimental Traumatic Brain Injury Reduces Neurodegeneration and Neurological Deficits | Journal of Neuroscience \[jneurosci.org\]](#)
- [6. Microglial Depletion with CSF1R Inhibitor During Chronic Phase of Experimental Traumatic Brain Injury Reduces Neurodegeneration and Neurological Deficits - PMC \[pmc.ncbi.nlm.nih.gov\]](#)
- [7. CSF1R inhibitor PLX5622 and environmental enrichment additively improve metabolic outcomes in middle-aged female mice | Aging \[aging-us.com\]](#)
- [8. Microglia depletion increase brain injury after acute ischemic stroke in aged mice - PMC \[pmc.ncbi.nlm.nih.gov\]](#)
- [9. Csf1R inhibition attenuates experimental autoimmune encephalomyelitis and promotes recovery - PMC \[pmc.ncbi.nlm.nih.gov\]](#)
- [10. benchchem.com \[benchchem.com\]](#)
- [11. PLX5622 Clears Inflammatory Microglia in an Alzheimer's Mouse Model – Fight Aging! \[fightaging.org\]](#)
- [12. biorxiv.org \[biorxiv.org\]](#)
- [13. researchgate.net \[researchgate.net\]](#)
- [14. Targeting macrophage and microglia activation with colony stimulating factor 1 receptor inhibitor is an effective strategy to treat injury-triggered neuropathic pain - PMC \[pmc.ncbi.nlm.nih.gov\]](#)
- [15. fujifilmbiosciences.fujifilm.com \[fujifilmbiosciences.fujifilm.com\]](#)
- [16. onlineacademiccommunity.uvic.ca \[onlineacademiccommunity.uvic.ca\]](#)
- [17. Frontiers | Proposed practical protocol for flow cytometry analysis of microglia from the healthy adult mouse brain: Systematic review and isolation methods' evaluation \[frontiersin.org\]](#)
- [18. researchgate.net \[researchgate.net\]](#)
- [19. biorxiv.org \[biorxiv.org\]](#)
- [20. biorxiv.org \[biorxiv.org\]](#)
- [21. PLX5622 Reduces Disease Severity in Lethal CNS Infection by Off-Target Inhibition of Peripheral Inflammatory Monocyte Production - PubMed \[pubmed.ncbi.nlm.nih.gov\]](#)
- [22. PLX5622 Reduces Disease Severity in Lethal CNS Infection by Off-Target Inhibition of Peripheral Inflammatory Monocyte Production - PMC \[pmc.ncbi.nlm.nih.gov\]](#)

- [23. Microglial repopulation resolves inflammation and promotes brain recovery after injury - PMC \[pmc.ncbi.nlm.nih.gov\]](#)
- [24. Frontiers | PLX5622 Reduces Disease Severity in Lethal CNS Infection by Off-Target Inhibition of Peripheral Inflammatory Monocyte Production \[frontiersin.org\]](#)
- To cite this document: BenchChem. [A Technical Guide to Studying Neuroinflammation with PLX5622]. BenchChem, [2026]. [Online PDF]. Available at: [\[https://www.benchchem.com/product/b15541549/docs#a-technical-guide-to-studying-neuroinflammation-with-plx5622\]](https://www.benchchem.com/product/b15541549/docs#a-technical-guide-to-studying-neuroinflammation-with-plx5622)

Disclaimer & Data Validity:

The information provided in this document is for Research Use Only (RUO) and is strictly not intended for diagnostic or therapeutic procedures. While BenchChem strives to provide accurate protocols, we make no warranties, express or implied, regarding the fitness of this product for every specific experimental setup.

Technical Support: The protocols provided are for reference purposes. Unsure if this reagent suits your experiment?

Need Industrial/Bulk Grade? [Request Custom Synthesis Quote](#)

BenchChem

Our mission is to be the trusted global source of essential and advanced chemicals, empowering scientists and researchers to drive progress in science and industry.

Contact

Address: 3281 E Guasti Rd
Ontario, CA 91761, United States
Phone: (601) 213-4426
Email: info@benchchem.com

[Contact our Ph.D. Support Team for a compatibility check](#)

