

A Technical Guide to Stevia Extraction for Scientific Investigation

Author: BenchChem Technical Support Team. **Date:** April 2026

Compound of Interest

Compound Name: Stevia Powder

Cat. No.: B15541331

[Get Quote](#)

This in-depth guide provides researchers, scientists, and drug development professionals with a comprehensive overview of core techniques for the extraction and purification of steviol glycosides from *Stevia rebaudiana* leaves. It details experimental protocols, presents comparative quantitative data, and illustrates key workflows for scientific study.

Introduction

Stevia rebaudiana Bertoni produces a class of high-intensity, low-calorie sweeteners known as steviol glycosides. The primary glycosides of commercial and scientific interest are stevioside and rebaudioside A, with rebaudioside A being particularly valued for its superior taste profile, exhibiting less bitterness.[1] The extraction and purification of these compounds are critical for their application in food, pharmaceuticals, and for detailed scientific research into their therapeutic properties, which are reported to include antihyperglycemic, antihypertensive, and anti-inflammatory effects.[1] This document outlines and compares various extraction and purification methodologies, providing detailed protocols to facilitate reproducible scientific inquiry.

Pre-Extraction Processing

Prior to the primary extraction, a series of preparatory steps are crucial for enhancing the efficiency of steviol glycoside isolation.

Experimental Protocol: Leaf Preparation and Pre-Treatment

- **Harvesting and Drying:** Harvest *Stevia rebaudiana* leaves, typically during the flowering stage for optimal glycoside content.[2] Air-dry the leaves in the shade, followed by oven drying at approximately 50-60°C for 24-48 hours to achieve a moisture content near zero.[3][4]
- **Grinding:** Grind the dried leaves into a fine powder. A particle size of around 500 microns or a 30-50 mesh size is often used to increase the surface area for solvent interaction.[4][5]
- **Defatting (Optional but Recommended):** To remove non-polar impurities such as chlorophyll, waxes, and oils that can interfere with subsequent purification steps, a pre-treatment with a non-polar solvent is effective.[6] Soak the powdered leaves in a solvent like hexane or petroleum ether.[3] This step is crucial for improving the purity of the final extract. An ethanolic pre-treatment has also been shown to enhance the sensory profile of the final product by reducing bitterness.[6]

Primary Extraction Methodologies

The selection of an extraction technique is pivotal, influencing yield, purity, and processing time. Both conventional and modern "green" technologies are employed.

Conventional Solvent Extraction (Maceration/Hot Water)

This is a traditional, widely used method due to its simplicity and scalability.[1]

Experimental Protocol: Hot Water Extraction

- **Solvent and Ratio:** Use distilled water as the solvent. A common leaf-to-water ratio is 1:14 (g:mL).[6]
- **Extraction Conditions:** Mix the powdered stevia leaves with water and heat the mixture. Optimal conditions have been identified as 78°C for 56 minutes.[6] For a simpler setup, refluxing with methanol for 1 hour in a hot water bath is also effective.[1]

- Filtration: After extraction, cool the mixture and filter it under vacuum to separate the liquid extract from the solid leaf residue.[1]
- Repeated Extraction: To maximize yield, the plant residue can be subjected to further extraction cycles.[1]

Microwave-Assisted Extraction (MAE)

MAE utilizes microwave energy to heat the solvent and plant material, accelerating the extraction process.[2]

Experimental Protocol: Microwave-Assisted Extraction

- Apparatus: A microwave extractor system equipped with controls for power, temperature, and time.[2]
- Solvent: A binary mixture of methanol and water (80:20, v/v) has been shown to be effective. [2]
- Parameters: For a 100 mg sample in 10 mL of solvent, optimal conditions are a microwave power of 80 W for 1 minute at a temperature of 50°C.[2][7]
- Post-Extraction: After irradiation, centrifuge the sample to separate the supernatant (extract). [8]

Ultrasound-Assisted Extraction (UAE)

UAE employs acoustic cavitation to disrupt plant cell walls, enhancing solvent penetration and mass transfer.[9][10]

Experimental Protocol: Ultrasound-Assisted Extraction

- Apparatus: An ultrasonic bath or a probe-type sonicator. A common frequency is 20-25 kHz. [8][10]
- Solvent: Water or aqueous ethanol solutions (e.g., 20% ethanol) are typically used.[9][10]

- Parameters: Mix the powdered stevia (e.g., 1:10 or 1:20 solid-to-liquid ratio) and sonicate.[8]
[9] Optimal conditions can be achieved at 50°C for 30-43 minutes with high ultrasonic power.
[9][11]
- Recovery: Separate the extract from the solid residue by filtration or centrifugation.[8]

Supercritical Fluid Extraction (SFE)

SFE uses a supercritical fluid, typically CO₂, as a solvent. This method is highly selective and leaves minimal solvent residue.[12]

Experimental Protocol: Supercritical Fluid Extraction

- Apparatus: A supercritical fluid extraction system.
- Solvent System: Supercritical CO₂ is the primary solvent. A polar co-solvent, such as an ethanol-water mixture, is necessary to extract the polar steviol glycosides.[12][13]
- Parameters: Optimal conditions have been reported at a pressure of 211 bar, a temperature of 80°C, with 17.4% of an ethanol-water (70:30) mixture as a co-solvent, and a CO₂ flow rate of 15 g/min for 60 minutes.[12][13]
- Two-Step Process: A common approach involves an initial pre-treatment step with pure supercritical CO₂ (e.g., 200 bar, 30°C) to remove non-polar compounds, followed by the main extraction with the addition of a co-solvent.[12][14]

Enzymatic Extraction

This method uses enzymes like cellulase and hemicellulase to break down the plant cell wall, facilitating the release of steviol glycosides.

Experimental Protocol: Enzymatic Extraction

- Enzyme Solution: Prepare a solution of hydrolytic enzymes (e.g., cellulase, hemicellulase, pectinase) in a suitable buffer, such as 0.1M acetate buffer at pH 5.[5]
- Incubation: Suspend the powdered stevia leaves in the enzyme solution.

- Conditions: Incubate the mixture for approximately 4 hours in a shaking incubator.^[5] Optimal temperatures are typically in the range of 51-54°C.
- Extraction: Following enzymatic treatment, proceed with a standard solvent extraction (e.g., hot water) to recover the released glycosides.

Comparative Analysis of Extraction Techniques

The choice of extraction method significantly impacts the yield of steviol glycosides. The following table summarizes quantitative data from comparative studies.

Extraction Method	Stevioside Yield (%)	Rebaudioside A Yield (%)	Extraction Time	Temperature (°C)	Reference
Conventional (Cold Maceration)	6.54	1.20	12 h	25	[7]
Ultrasound-Assisted (UAE)	4.20	1.98	30 min	35 ± 5	[7]
Microwave-Assisted (MAE)	8.64	2.34	1 min	50	[7][11]
Supercritical Fluid (SFE)	3.67 (36.66 mg/g)	1.78 (17.79 mg/g)	60 min	80	[12][13]
Hot Water Extraction (Optimized)	-	73.12% Recovery	51 min	71	[2]

Note: Yields can vary significantly based on the quality of the plant material and specific experimental conditions.

Post-Extraction Purification Workflow

A multi-step purification process is essential to remove impurities and isolate specific steviol glycosides.

Clarification

The initial crude extract contains suspended solids, pigments, and high-molecular-weight compounds that must be removed.

Experimental Protocol: Clarification

- Flocculation: Treat the aqueous extract with flocculating agents like calcium hydroxide or aluminum salts, followed by filtration.
- Microfiltration (MF): Pass the extract through a microfiltration membrane (typically 0.1 to 10 μm pore size) to remove suspended solids, cell debris, and microorganisms.[15]

Decolorization and Initial Purification

This stage aims to remove colored compounds and other impurities.

Experimental Protocol: Ion-Exchange and Adsorption Chromatography

- Activated Carbon: Pass the clarified extract through a column packed with activated carbon to adsorb residual plant pigments.[16]
- Cation Exchange: Use a strong cation exchange resin to remove salts and cationic organic impurities.[16]
- Anion Exchange: Subsequently, pass the extract through an anion exchange resin bed (e.g., Amberlite-FPA53 OH⁻ form) to remove anions and remaining pigments.[16][17]
- Adsorbent Resin: Use a macroporous adsorbent resin (e.g., AB-8, X-5) that has a high affinity for steviol glycosides to capture them from the aqueous solution.[16][18]
- Elution: Elute the adsorbed steviol glycosides from the adsorbent resin using an alcohol, typically ethanol.[16]

Concentration and Fine Purification

Membrane filtration is a green technology used for concentrating the extract and separating glycosides.

Experimental Protocol: Membrane Filtration

- Ultrafiltration (UF): Use a UF membrane with a molecular weight cut-off (MWCO) of approximately 30 kDa to separate high-molecular-weight impurities, retaining them while allowing the smaller steviol glycosides to pass through in the permeate.[19]
- Nanofiltration (NF): Concentrate the permeate from the UF step using an NF membrane (MWCO of ~250 Da). This step retains the steviol glycosides in the retentate while allowing water and some salts to pass through, effectively concentrating the product.[19]

Isolation of High-Purity Steviol Glycosides

Crystallization is the final step to obtain high-purity individual steviol glycosides, particularly Rebaudioside A.

Experimental Protocol: Crystallization of Rebaudioside A

- Solvent System: Dissolve the purified and concentrated steviol glycoside mixture in an aqueous organic solvent. A mixture of ethanol and water is commonly used.[20] Methanol aqueous solutions are also effective.[21]
- Dissolution: Heat the mixture under reflux to completely dissolve the glycosides.[11]
- Crystallization: Cool the solution slowly to induce crystallization. Rebaudioside A has different solubility compared to stevioside in these solvent systems, allowing for its selective precipitation.[5][22]
- Separation and Drying: Separate the Rebaudioside A crystals from the mother liquor via centrifugation. Dry the crystals in a vacuum tray dryer.[11] The mother liquor, rich in other glycosides like stevioside, can be further processed.[11]

Analytical Quantification

High-Performance Liquid Chromatography (HPLC) is the standard method for the separation and quantification of individual steviol glycosides.

Experimental Protocol: HPLC Analysis

- System: An HPLC system equipped with a UV detector.
- Column: A reversed-phase C18 column (e.g., 250 mm length, 4.6 mm inner diameter, 5 μ m particle size) is commonly used.[23] An amino column is also effective.
- Mobile Phase: An isocratic mobile phase consisting of a mixture of acetonitrile and a sodium phosphate buffer (e.g., 32:68 v/v at pH 2.6) is frequently employed.[23][24] A common mobile phase for amino columns is acetonitrile:water (80:20, v/v).[24]
- Detection: Set the UV detector to 210 nm.[23][24]
- Quantification: Prepare standard solutions of pure stevioside and rebaudioside A to generate an external standard calibration curve for accurate quantification.[24]

Visualizing the Workflow

The following diagrams illustrate the key stages in Stevia extraction and purification.

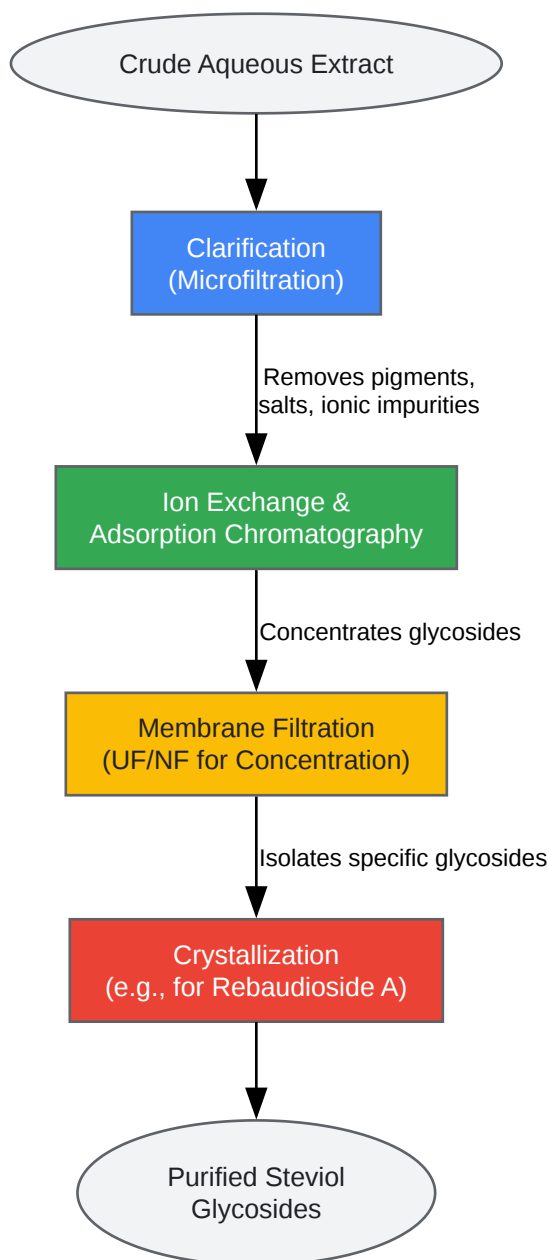
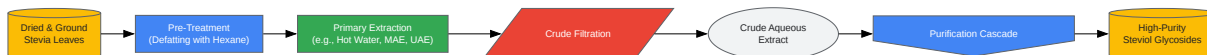

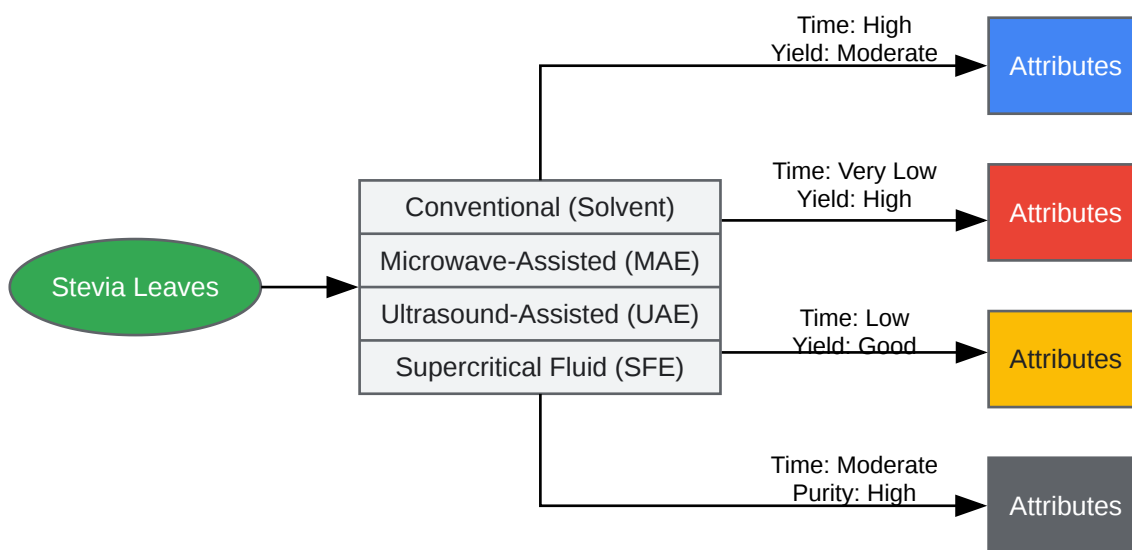

[Click to download full resolution via product page](#)

Need Custom Synthesis?

BenchChem offers custom synthesis for rare earth carbides and specific isotopic labeling.

Email: info@benchchem.com or [Request Quote Online](#).

References

1. ijpsonline.com [ijpsonline.com]
2. files.core.ac.uk [files.core.ac.uk]
3. plantsjournal.com [plantsjournal.com]
4. bibliotekanauki.pl [bibliotekanauki.pl]
5. US20180153196A1 - Enzyme-assisted extraction of steviol glycosides from the leaves of stevia rebaudiana bertonii - Google Patents [patents.google.com]
6. cetjournal.it [cetjournal.it]
7. An efficient microwave-assisted extraction process of stevioside and rebaudioside-A from Stevia rebaudiana (Bertonii) - PubMed [pubmed.ncbi.nlm.nih.gov]
8. cetjournal.it [cetjournal.it]
9. mdpi.com [mdpi.com]

- [10. Ultrasound-assisted Extraction Process of Glycosides from Stevia Rebaudiana Bertoni Leaves | Chemical Engineering Transactions \[cetjournal.it\]](#)
- [11. researchgate.net \[researchgate.net\]](#)
- [12. steviashantanu.com \[steviashantanu.com\]](#)
- [13. researchgate.net \[researchgate.net\]](#)
- [14. scielo.br \[scielo.br\]](#)
- [15. steviashantanu.com \[steviashantanu.com\]](#)
- [16. steviashantanu.com \[steviashantanu.com\]](#)
- [17. ES2787899T3 - Methods to purify steviol glycosides - Google Patents \[patents.google.com\]](#)
- [18. CN102816193B - A kind of method of resin column method extraction purification steviol glycoside from stevia rebaudiana water extract of connecting - Google Patents \[patents.google.com\]](#)
- [19. Simple extraction and membrane purification process in isolation of steviosides with improved organoleptic activity \[scirp.org\]](#)
- [20. international-agrophysics.org \[international-agrophysics.org\]](#)
- [21. mdpi.com \[mdpi.com\]](#)
- [22. Solubility of Stevioside and Rebaudioside A in water, ethanol and their binary mixtures | International Journal of Food Studies \[iseki-food-ejournal.com\]](#)
- [23. Validation of an HPLC Method for Pretreatment of Steviol Glycosides in Fermented Milk - PMC \[pmc.ncbi.nlm.nih.gov\]](#)
- [24. tools.thermofisher.com \[tools.thermofisher.com\]](#)
- To cite this document: BenchChem. [A Technical Guide to Stevia Extraction for Scientific Investigation]. BenchChem, [2026]. [Online PDF]. Available at: [\[https://www.benchchem.com/product/b15541331/docs#a-technical-guide-to-stevia-extraction-for-scientific-investigation\]](https://www.benchchem.com/product/b15541331/docs#a-technical-guide-to-stevia-extraction-for-scientific-investigation)

Disclaimer & Data Validity:

The information provided in this document is for Research Use Only (RUO) and is strictly not intended for diagnostic or therapeutic procedures. While BenchChem strives to provide accurate protocols, we make no warranties, express or implied, regarding the fitness of this product for every specific experimental setup.

Technical Support: The protocols provided are for reference purposes. Unsure if this reagent suits your experiment?

Need Industrial/Bulk Grade? [Request Custom Synthesis Quote](#)

BenchChem

Our mission is to be the trusted global source of essential and advanced chemicals, empowering scientists and researchers to drive progress in science and industry.

Contact

Address: 3281 E Guasti Rd
Ontario, CA 91761, United States
Phone: (601) 213-4426
Email: info@benchchem.com

[Contact our Ph.D. Support Team for a compatibility check](#)