

troubleshooting common problems in Chrysomycin A antibacterial assays

Author: BenchChem Technical Support Team. **Date:** April 2026

Compound of Interest

Compound Name: Chrysomycin A

Cat. No.: B15540798

[Get Quote](#)

Technical Support Center: Chrysomycin A Antibacterial Assays

This technical support center provides troubleshooting guidance and frequently asked questions (FAQs) for researchers utilizing **Chrysomycin A** in antibacterial assays. The information is tailored for scientists and professionals in the field of drug development and microbiology.

Frequently Asked Questions (FAQs)

Q1: What is the mechanism of action of **Chrysomycin A**?

A1: **Chrysomycin A** exerts its antibacterial effect primarily by inhibiting DNA topoisomerase I, an essential enzyme for DNA replication and repair in bacteria.[1][2] It has also been shown to interact with DNA at specific sequences.[1][2] This dual action leads to a bactericidal effect against susceptible microorganisms.[3]

Q2: Against which types of bacteria is **Chrysomycin A** most effective?

A2: **Chrysomycin A** demonstrates potent activity against Gram-positive bacteria, including clinically significant strains like *Mycobacterium tuberculosis* (including multidrug-resistant strains), *Staphylococcus aureus* (including MRSA), and *Enterococcus faecalis* (including VRE). [3][4] It is generally not effective against Gram-negative bacteria such as *E. coli*, *Pseudomonas aeruginosa*, and *Vibrio cholerae*. [3]

Q3: What are the typical Minimum Inhibitory Concentration (MIC) values for **Chrysomycin A**?

A3: MIC values for **Chrysomycin A** can vary depending on the bacterial species and strain. The following table summarizes reported MIC values from various studies.

Bacterial Species	Strain	MIC (µg/mL)	Reference
<i>Mycobacterium tuberculosis</i>	H37Rv	3.125	[3][5]
<i>Mycobacterium tuberculosis</i>	MDR strains	0.4	[6]
<i>Staphylococcus aureus</i>	MRSA	2	[3]
<i>Enterococcus faecalis</i>	VRE	0.5	[3]
<i>Mycobacterium smegmatis</i>	mc ² 155	0.6	[3]
<i>Bacillus subtilis</i>	Not specified	[3]	

Q4: Is **Chrysomycin A** cytotoxic to mammalian cells?

A4: **Chrysomycin A** has been shown to have negligible cytotoxicity and is non-hemolytic at its effective antibacterial concentrations. [3][7] For example, it did not harm human erythrocytes even at concentrations ten times its MIC against *M. tuberculosis*. [3][7]

Troubleshooting Guide

This guide addresses common problems encountered during antibacterial susceptibility testing with **Chrysomycin A**.

Issue 1: No Zone of Inhibition in Disk Diffusion Assay

- Possible Cause 1: Bacterial Resistance. The test organism may be inherently resistant to **Chrysomycin A**, particularly if it is a Gram-negative bacterium.[3]
 - Solution: Confirm the bacterial species and its known susceptibility profile to **Chrysomycin A**. Test against a known susceptible Gram-positive control strain.
- Possible Cause 2: Incorrect Disk Potency. The **Chrysomycin A** on the disk may have degraded or be at too low a concentration.
 - Solution: Ensure proper storage of **Chrysomycin A** stock solutions and prepared disks. Verify the concentration of **Chrysomycin A** applied to the disks. Run a quality control check with a fresh batch of disks.
- Possible Cause 3: Inappropriate Assay Conditions. The growth medium or incubation conditions may not be suitable for the test organism.
 - Solution: Use the recommended medium (e.g., Mueller-Hinton agar) and incubate at the optimal temperature and duration for the specific bacterial strain.[8]

Issue 2: Inconsistent or Noisy Results in Broth Microdilution (MIC) Assay

- Possible Cause 1: Poor Solubility of **Chrysomycin A**. **Chrysomycin A** is a complex molecule and may not be fully soluble in the assay medium, leading to inaccurate concentrations.
 - Solution: Prepare a high-concentration stock solution of **Chrysomycin A** in a suitable solvent like DMSO.[7] Ensure the final concentration of the solvent in the assay does not exceed a level that affects bacterial growth (typically $\leq 1\%$).[7]
- Possible Cause 2: Bacterial Clumping. Aggregation of bacteria can lead to variable inoculum sizes in the wells.
 - Solution: Vortex the bacterial suspension thoroughly before inoculation to ensure a homogenous mixture.[9]

- Possible Cause 3: Pipetting Errors. Inaccurate serial dilutions will lead to incorrect final concentrations of **Chrysomycin A**.
 - Solution: Calibrate pipettes regularly and use appropriate pipetting techniques to ensure accuracy.[9]

Issue 3: Unexpectedly High MIC Values

- Possible Cause 1: High Inoculum Density. An overly dense bacterial culture can overwhelm the antibacterial agent, resulting in a higher apparent MIC.
 - Solution: Standardize the bacterial inoculum to a 0.5 McFarland standard to ensure a consistent starting cell density.[8][9]
- Possible Cause 2: Contamination. Contamination of the bacterial culture with a resistant organism can lead to growth at higher concentrations of **Chrysomycin A**.
 - Solution: Re-streak the bacterial culture to ensure its purity and repeat the assay.

Experimental Protocols

1. Broth Microdilution Assay for MIC Determination

This protocol outlines the steps to determine the Minimum Inhibitory Concentration (MIC) of **Chrysomycin A**.

- Preparation of **Chrysomycin A** Stock Solution: Dissolve **Chrysomycin A** in an appropriate solvent (e.g., DMSO) to create a high-concentration stock solution.
- Serial Dilutions: In a 96-well microtiter plate, perform two-fold serial dilutions of the **Chrysomycin A** stock solution using Mueller-Hinton Broth (MHB) to achieve the desired concentration range.
- Inoculum Preparation: Prepare a bacterial suspension in MHB and adjust its turbidity to match a 0.5 McFarland standard. This corresponds to approximately $1-2 \times 10^8$ CFU/mL.[8] Dilute this suspension to achieve a final concentration of approximately 5×10^5 CFU/mL in each well.[9]

- Inoculation: Add the standardized bacterial inoculum to each well of the microtiter plate. Include a positive control well (bacteria with no **Chrysomycin A**) and a negative control well (broth only).
- Incubation: Incubate the plate at the optimal temperature for the test bacterium (e.g., 37°C) for 16-20 hours.[8]
- Result Interpretation: The MIC is the lowest concentration of **Chrysomycin A** at which there is no visible growth of bacteria.[10][11]

2. Disk Diffusion Assay

This method provides a qualitative assessment of bacterial susceptibility to **Chrysomycin A**.

- Inoculum Preparation: Prepare a bacterial suspension adjusted to a 0.5 McFarland standard as described for the broth microdilution assay.[8]
- Plate Inoculation: Using a sterile cotton swab, evenly streak the bacterial suspension over the entire surface of a Mueller-Hinton agar plate.
- Disk Application: Aseptically apply a sterile paper disk impregnated with a known concentration of **Chrysomycin A** to the surface of the agar.
- Incubation: Invert the plate and incubate at the optimal temperature for the test bacterium for 16-18 hours.[8]
- Result Interpretation: Measure the diameter of the zone of inhibition (the clear area around the disk where bacterial growth is prevented). The size of the zone indicates the susceptibility of the bacterium to **Chrysomycin A**.

Visualizations

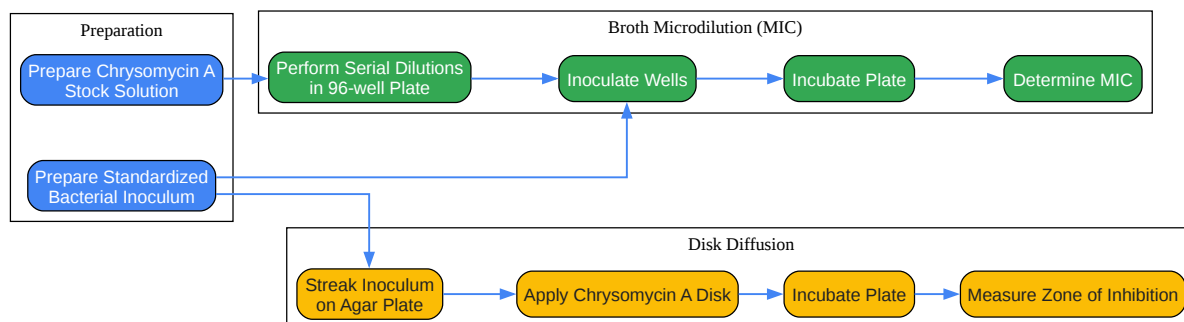

[Click to download full resolution via product page](#)

Caption: Workflow for antibacterial susceptibility testing of **Chrysomycin A**.

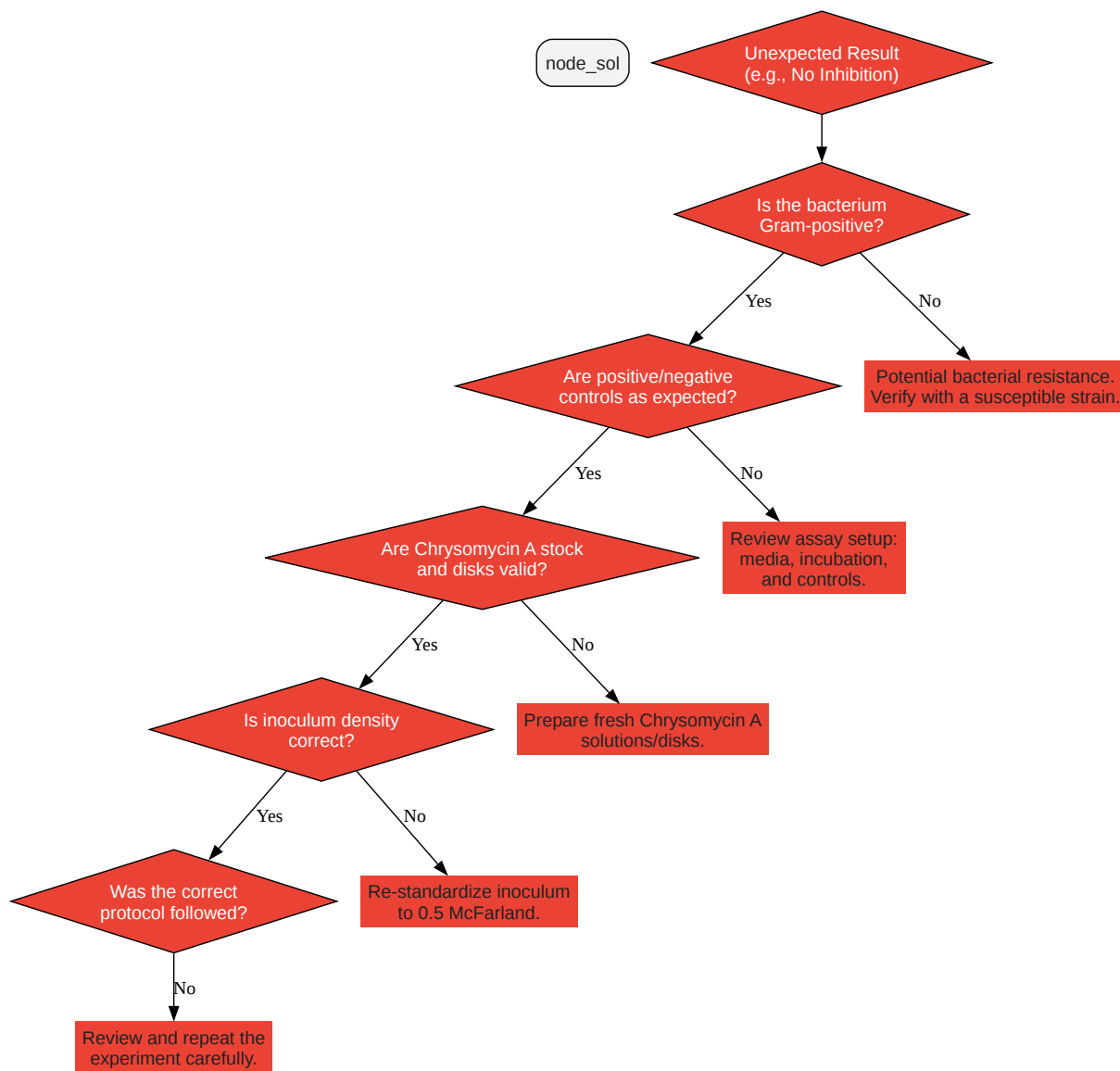

[Click to download full resolution via product page](#)

Caption: A logical troubleshooting guide for unexpected experimental outcomes.

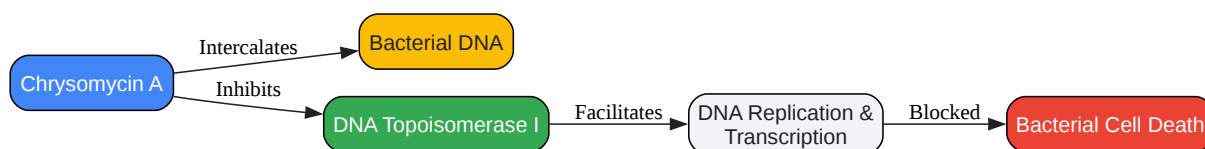

[Click to download full resolution via product page](#)

Caption: Mechanism of action of **Chrysomycin A** leading to bacterial cell death.

Need Custom Synthesis?

BenchChem offers custom synthesis for rare earth carbides and specific isotopic labeling.

Email: info@benchchem.com or [Request Quote Online](#).

References

- 1. Chrysomycin A inhibits the topoisomerase I of Mycobacterium tuberculosis | Semantic Scholar [semanticscholar.org]
- 2. Chrysomycin A inhibits the topoisomerase I of Mycobacterium tuberculosis - PubMed [pubmed.ncbi.nlm.nih.gov]
- 3. Anti-microbial activity of chrysomycin A produced by Streptomyces sp. against Mycobacterium tuberculosis - RSC Advances (RSC Publishing) DOI:10.1039/C7RA05576E [pubs.rsc.org]
- 4. Comparative Transcriptome Analysis of Two Chrysomycin-Producing Wild-Type and Mutant Strains of Streptomyces sp. 891 - PMC [pmc.ncbi.nlm.nih.gov]
- 5. Anti-microbial activity of chrysomycin A produced by Streptomyces sp. against Mycobacterium tuberculosis - RSC Advances (RSC Publishing) [pubs.rsc.org]
- 6. pubs.acs.org [pubs.acs.org]
- 7. pubs.rsc.org [pubs.rsc.org]
- 8. apec.org [apec.org]
- 9. benchchem.com [benchchem.com]

- [10. The Minimum Inhibitory Concentration of Antibiotics: Methods, Interpretation, Clinical Relevance - PMC \[pmc.ncbi.nlm.nih.gov\]](#)
- [11. bmglabtech.com \[bmglabtech.com\]](#)
- To cite this document: BenchChem. [troubleshooting common problems in Chryso mycin A antibacterial assays]. BenchChem, [2026]. [Online PDF]. Available at: [\[https://www.benchchem.com/product/b15540798/docs#troubleshooting-common-problems-in-chryso mycin-a-antibacterial-assays\]](https://www.benchchem.com/product/b15540798/docs#troubleshooting-common-problems-in-chryso mycin-a-antibacterial-assays)

Disclaimer & Data Validity:

The information provided in this document is for Research Use Only (RUO) and is strictly not intended for diagnostic or therapeutic procedures. While BenchChem strives to provide accurate protocols, we make no warranties, express or implied, regarding the fitness of this product for every specific experimental setup.

Technical Support: The protocols provided are for reference purposes. Unsure if this reagent suits your experiment?

Need Industrial/Bulk Grade? [Request Custom Synthesis Quote](#)

BenchChem

Our mission is to be the trusted global source of essential and advanced chemicals, empowering scientists and researchers to drive progress in science and industry.

Contact

Address: 3281 E Guasti Rd
Ontario, CA 91761, United States
Phone: (601) 213-4426
Email: info@benchchem.com

[Contact our Ph.D. Support Team for a compatibility check](#)

