

Application Notes and Protocols for High-Throughput Screening of Pin1 Inhibitors

Author: BenchChem Technical Support Team. **Date:** April 2026

Compound of Interest

Compound Name: *PIN1 ligand-1*

Cat. No.: *B15540921*

[Get Quote](#)

For Researchers, Scientists, and Drug Development Professionals

This document provides detailed application notes and protocols for the high-throughput screening (HTS) of inhibitors targeting Peptidyl-prolyl cis-trans isomerase NIMA-interacting 1 (Pin1). Pin1 is a critical enzyme in cellular signaling, and its dysregulation is implicated in various diseases, including cancer. These protocols are designed to guide researchers in the discovery and characterization of novel Pin1 inhibitors.

Introduction to Pin1 and its Role in Cellular Signaling

Pin1 is a unique peptidyl-prolyl isomerase (PPIase) that specifically recognizes and catalyzes the cis-trans isomerization of pSer/Thr-Pro motifs in proteins. This conformational change can have profound effects on protein function, including stability, localization, and activity, thereby regulating numerous cellular processes. Pin1 is a key player in several oncogenic signaling pathways, making it an attractive target for therapeutic intervention.

Below is a diagram illustrating the central role of Pin1 in integrating multiple oncogenic signaling pathways. Pin1 can activate oncogenes and inactivate tumor suppressors,

contributing to tumorigenesis.[1][2][3][4]

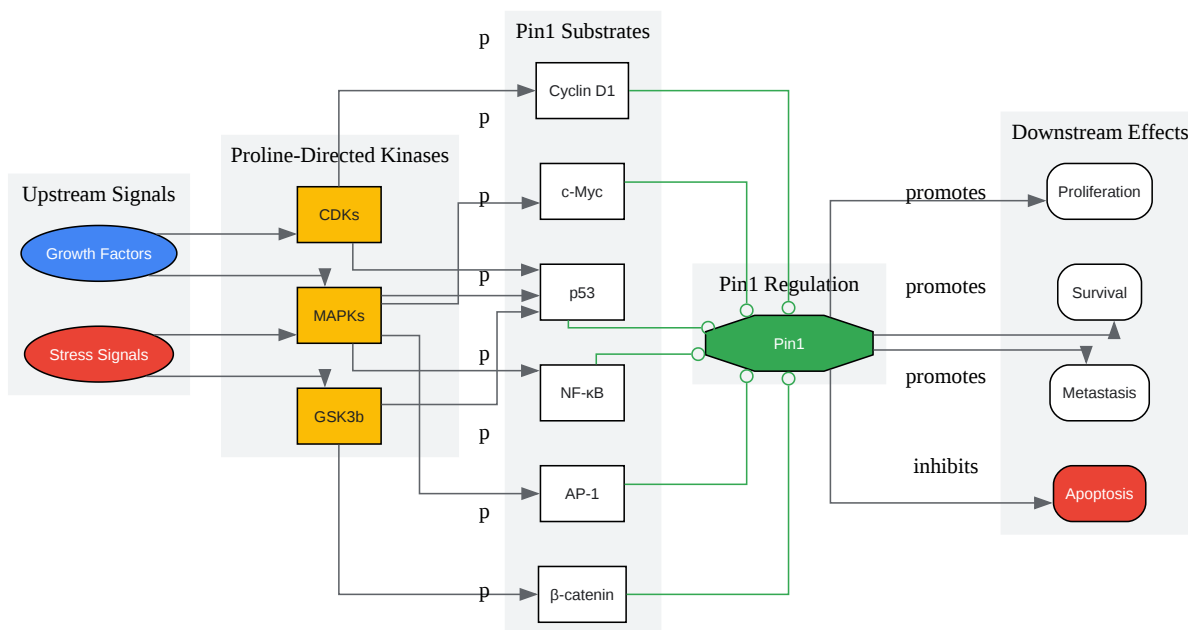

[Click to download full resolution via product page](#)

Figure 1: Pin1 as a central hub in oncogenic signaling pathways.

High-Throughput Screening (HTS) Assays for Pin1 Inhibitors

Several HTS-compatible assays have been developed to identify and characterize Pin1 inhibitors. The most common formats are the chymotrypsin-coupled PPIase assay, fluorescence polarization (FP) assay, and time-resolved fluorescence resonance energy transfer (TR-FRET) assay.

The general workflow for an HTS campaign to identify Pin1 inhibitors is depicted below.

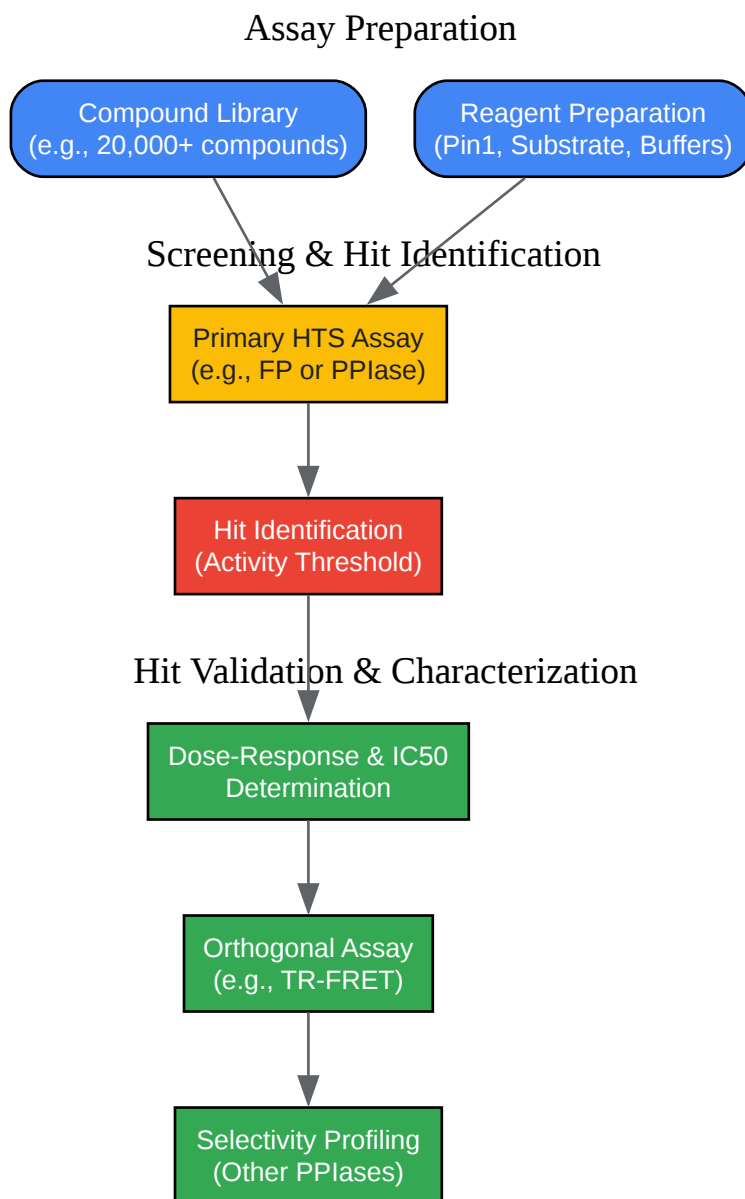

[Click to download full resolution via product page](#)

Figure 2: General workflow for HTS of Pin1 inhibitors.

Data Presentation: Quantitative Analysis of Pin1 Inhibitors

The following table summarizes the inhibitory activities of several known Pin1 inhibitors identified through various screening methods.

Compound Name	Assay Type	IC50	Ki	Reference
Juglone	PPlase	0.8 μ M	-	[5]
ATRA	PPlase	33.2 μ M	-	[3]
KPT-6566	PPlase	-	23 nM	[5]
BJP-06-005-3	PPlase	48 nM	48 nM	[1]
VS1	Enzymatic	6.4 μ M	-	[3]
VS2	Enzymatic	29.3 μ M	-	[3]
HWH8-33	PPlase	~5 μ M	-	[6]
HWH8-36	PPlase	~10 μ M	-	[6]

Experimental Protocols

Chymotrypsin-Coupled Peptidyl-Prolyl Isomerase (PPlase) Assay

This assay measures the Pin1-catalyzed isomerization of a chromogenic peptide substrate. The substrate, typically Suc-Ala-Ala-Pro-Phe-pNA or a similar sequence, exists in both cis and trans conformations. Chymotrypsin can only cleave the trans isomer, releasing p-nitroaniline (pNA), which can be detected spectrophotometrically at 390-405 nm. Pin1 accelerates the conversion of the cis to the trans form, thus increasing the rate of pNA release.

Materials:

- Recombinant human Pin1
- Substrate: N-Suc-Ala-Ala-Pro-Phe-p-nitroanilide (or similar)
- α -Chymotrypsin

- Assay Buffer: 35 mM HEPES, pH 7.8
- 96- or 384-well microplates
- Spectrophotometer plate reader

Protocol:

- Prepare a stock solution of the peptide substrate in DMSO and then dilute it in ice-cold 0.47 M LiCl in 2-propanol.
- Prepare the reaction mixture containing assay buffer and the desired concentration of Pin1.
- Add the test compounds at various concentrations to the wells of the microplate. Include positive controls (known inhibitor) and negative controls (DMSO vehicle).
- Add the Pin1 solution to the wells and pre-incubate with the compounds for a specified time (e.g., 15 minutes) at room temperature.
- Initiate the reaction by adding a mixture of the substrate and chymotrypsin to each well.
- Immediately measure the absorbance at 390 nm or 405 nm in kinetic mode for 5-10 minutes at 25°C.
- The rate of the reaction is determined from the linear portion of the absorbance curve. Calculate the percent inhibition for each compound concentration and determine the IC₅₀ value.

Fluorescence Polarization (FP) Assay

This competitive binding assay measures the displacement of a fluorescently labeled peptide probe from the Pin1 active site by a test compound. The small fluorescent probe, when unbound, tumbles rapidly in solution, resulting in low fluorescence polarization. When bound to the larger Pin1 protein, its tumbling is restricted, leading to a high polarization signal. Inhibitors that bind to the active site will displace the probe, causing a decrease in polarization.

Materials:

- Recombinant human Pin1
- Fluorescently labeled peptide probe (e.g., a fluorescein-labeled peptide containing the pSer/Thr-Pro motif)
- Assay Buffer: 10 mM HEPES, pH 7.5, 10 mM NaCl, 0.01% Tween-20, 1 mM DTT
- Black, low-volume 384- or 1536-well microplates
- Fluorescence polarization plate reader

Protocol:

- To the wells of the microplate, add the assay buffer.
- Add the test compounds at various concentrations. Include positive controls (unlabeled competitor peptide or known inhibitor) and negative controls (DMSO vehicle).
- Add the fluorescent probe to all wells at a fixed concentration (typically in the low nanomolar range).
- Initiate the reaction by adding Pin1 to all wells except for the "no enzyme" control wells.
- Incubate the plate at room temperature for a specified time (e.g., 30-60 minutes) to reach binding equilibrium.
- Measure the fluorescence polarization using a plate reader with appropriate excitation and emission filters (e.g., 485 nm excitation and 535 nm emission for fluorescein).
- Calculate the percent inhibition based on the decrease in polarization signal and determine the IC₅₀ values.

Time-Resolved Fluorescence Resonance Energy Transfer (TR-FRET) Assay

This assay measures the interaction between Pin1 and a labeled substrate. Typically, Pin1 is tagged with a donor fluorophore (e.g., Europium cryptate), and a biotinylated peptide substrate is used in conjunction with a streptavidin-conjugated acceptor fluorophore (e.g., XL665 or d2).

When Pin1 binds to the substrate, the donor and acceptor are brought into close proximity, resulting in a FRET signal. Inhibitors that disrupt this interaction will lead to a decrease in the FRET signal.

Materials:

- Tagged recombinant human Pin1 (e.g., His-tagged or GST-tagged)
- Antibody against the tag labeled with a donor fluorophore (e.g., anti-His-Europium)
- Biotinylated peptide substrate containing the pSer/Thr-Pro motif
- Streptavidin labeled with an acceptor fluorophore (e.g., Streptavidin-d2)
- Assay Buffer: 50 mM HEPES, pH 7.0, 150 mM NaCl, 0.01% BSA, 0.05% Tween-20
- Low-volume 384- or 1536-well microplates
- TR-FRET compatible plate reader

Protocol:

- Add the test compounds at various concentrations to the wells of the microplate. Include positive and negative controls.
- Add a mixture of the tagged Pin1 and the donor-labeled antibody to the wells.
- Add a mixture of the biotinylated peptide substrate and the acceptor-labeled streptavidin to the wells.
- Incubate the plate at room temperature for 1-2 hours, protected from light.
- Measure the TR-FRET signal using a plate reader with appropriate excitation and emission wavelengths (e.g., 320 nm or 340 nm excitation, and emission at 620 nm for the donor and 665 nm for the acceptor).
- Calculate the FRET ratio (acceptor signal / donor signal) and then the percent inhibition to determine IC50 values.

Assay Quality and Performance

A critical parameter for evaluating the quality of an HTS assay is the Z'-factor.[7][8] The Z'-factor is a statistical measure of the separation between the positive and negative controls and is calculated using the following formula:

$$Z' = 1 - (3 * (\sigma_p + \sigma_n)) / |\mu_p - \mu_n|$$

where σ_p and σ_n are the standard deviations of the positive and negative controls, and μ_p and μ_n are the means of the positive and negative controls, respectively.

- $Z' > 0.5$: An excellent assay, highly suitable for HTS.
- $0 < Z' < 0.5$: A marginal assay, may require optimization.
- $Z' < 0$: The assay is not suitable for HTS.

It is recommended to determine the Z'-factor during assay development and to monitor it throughout the screening campaign to ensure data quality.

Screening Library and Hit Rate

The choice of a screening library is crucial for the success of an HTS campaign. Libraries can range from diverse collections of small molecules to more focused sets of compounds with known kinase-inhibitor-like scaffolds. A typical HTS campaign might screen tens of thousands to over a hundred thousand compounds.[6][9] The hit rate, which is the percentage of compounds identified as active in the primary screen, can vary widely depending on the library and the assay stringency, but is often in the range of 0.1% to 1%.[6] It is important to follow up on primary hits with secondary assays and dose-response studies to eliminate false positives and confirm the activity of true inhibitors.

Need Custom Synthesis?

BenchChem offers custom synthesis for rare earth carbides and specific isotopic labeling.

Email: info@benchchem.com or [Request Quote Online](#).

References

- [1. researchgate.net \[researchgate.net\]](#)
- [2. researchgate.net \[researchgate.net\]](#)
- [3. researchgate.net \[researchgate.net\]](#)
- [4. Pin1 as a central node in oncogenic signaling: Mechanistic insights and clinical prospects \(Review\) - PMC \[pmc.ncbi.nlm.nih.gov\]](#)
- [5. Targeted degradation of Pin1 by protein-destabilizing compounds - PMC \[pmc.ncbi.nlm.nih.gov\]](#)
- [6. Frontiers | Small molecules targeting Pin1 as potent anticancer drugs \[frontiersin.org\]](#)
- [7. assay.dev \[assay.dev\]](#)
- [8. Z-factor - Wikipedia \[en.wikipedia.org\]](#)
- [9. Development of high-throughput TR-FRET and AlphaScreen assays for identification of potent inhibitors of PDK1 - PubMed \[pubmed.ncbi.nlm.nih.gov\]](#)
- [To cite this document: BenchChem. \[Application Notes and Protocols for High-Throughput Screening of Pin1 Inhibitors\]. BenchChem, \[2026\]. \[Online PDF\]. Available at: \[https://www.benchchem.com/product/b15540921/docs#application-notes-and-protocols-for-high-throughput-screening-of-pin1-inhibitors\]](#)

Disclaimer & Data Validity:

The information provided in this document is for Research Use Only (RUO) and is strictly not intended for diagnostic or therapeutic procedures. While BenchChem strives to provide accurate protocols, we make no warranties, express or implied, regarding the fitness of this product for every specific experimental setup.

Technical Support: The protocols provided are for reference purposes. Unsure if this reagent suits your experiment?

Need Industrial/Bulk Grade? [Request Custom Synthesis Quote](#)

BenchChem

Our mission is to be the trusted global source of essential and advanced chemicals, empowering scientists and researchers to drive progress in science and industry.

Contact

Address: 3281 E Guasti Rd

Ontario, CA 91761, United States

Phone: (601) 213-4426

Email: info@benchchem.com

[Contact our Ph.D. Support Team for a compatibility check](#)