

Application Note: Quantitative Measurement of SHP2 Protein Levels Following SHP2-D26 Treatment

Author: BenchChem Technical Support Team. **Date:** April 2026

Compound of Interest

Compound Name: SHP2-D26

Cat. No.: B15540712

[Get Quote](#)

For Research Use Only. Not for use in diagnostic procedures.

Abstract

This application note provides detailed protocols for the quantitative measurement of total SHP2 protein levels in cultured cells following treatment with **SHP2-D26**, a novel research compound. The described methods include Western blotting and Enzyme-Linked Immunosorbent Assay (ELISA) for the sensitive and specific quantification of SHP2. This document is intended for researchers, scientists, and drug development professionals engaged in the study of SHP2 signaling and the characterization of targeted therapeutic agents.

Introduction

Src homology region 2-containing protein tyrosine phosphatase 2 (SHP2), encoded by the PTPN11 gene, is a non-receptor protein tyrosine phosphatase that plays a crucial role in various cellular signaling pathways.[1][2][3] SHP2 is involved in regulating cell growth, differentiation, migration, and survival by modulating key signaling cascades such as the RAS-RAF-MEK-ERK pathway.[1][2] Gain-of-function mutations in PTPN11 are associated with

developmental disorders and various malignancies, making SHP2 a compelling target for therapeutic intervention. **SHP2-D26** is a novel, potent, and selective allosteric inhibitor of SHP2 developed for research purposes. Accurate quantification of SHP2 protein levels following **SHP2-D26** treatment is essential for understanding its mechanism of action, target engagement, and downstream cellular effects.

SHP2 Signaling Pathway

The following diagram illustrates the central role of SHP2 in mediating signaling from receptor tyrosine kinases (RTKs) to the downstream RAS/MAPK pathway.

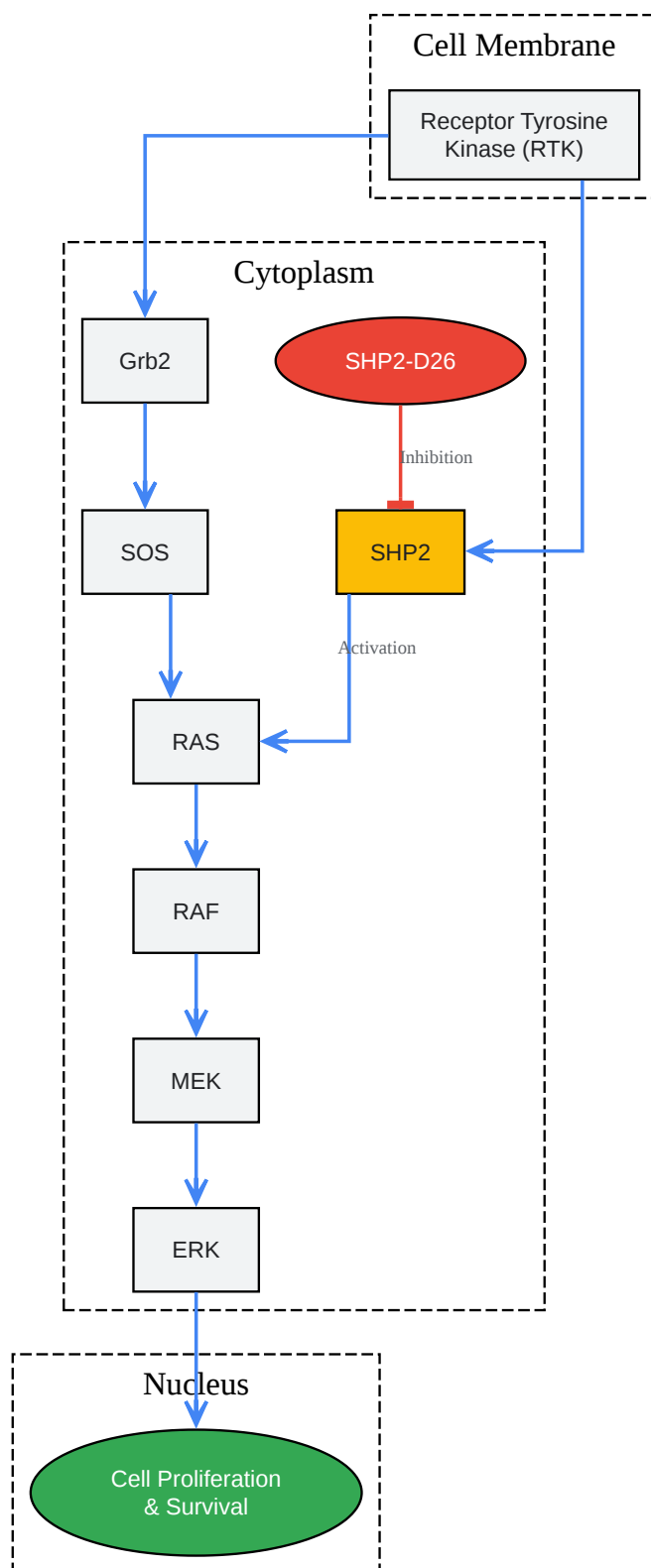

[Click to download full resolution via product page](#)

Caption: SHP2 signaling pathway and the inhibitory action of **SHP2-D26**.

Experimental Workflow

The overall workflow for the quantitative measurement of SHP2 protein levels is depicted below.

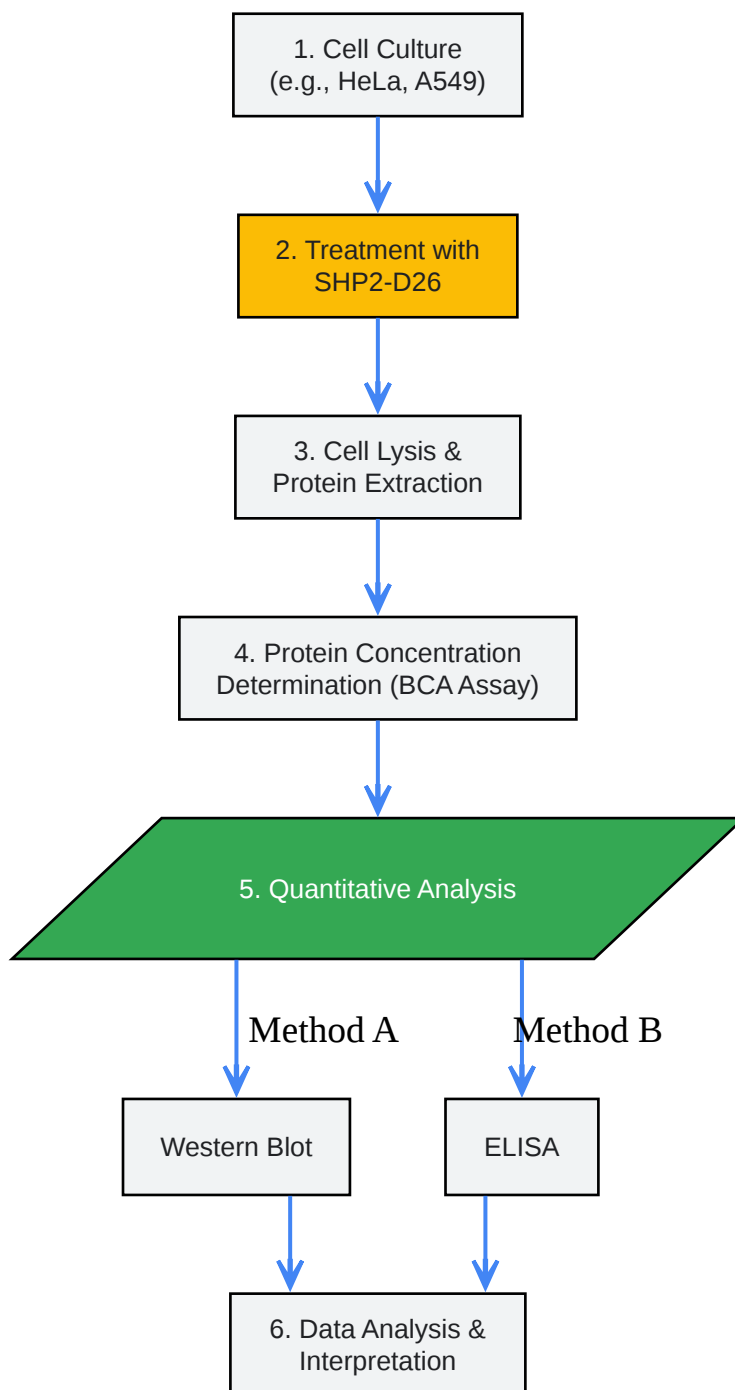

[Click to download full resolution via product page](#)

Caption: General workflow for SHP2 protein quantification after treatment.

Materials and Methods

Cell Culture and Treatment

- Cell Lines: HeLa (human cervical cancer) or A549 (human lung carcinoma) cells are suitable for this protocol.
- Culture Conditions: Culture cells in Dulbecco's Modified Eagle's Medium (DMEM) supplemented with 10% Fetal Bovine Serum (FBS) and 1% Penicillin-Streptomycin at 37°C in a humidified atmosphere with 5% CO₂.
- Seeding: Seed cells in 6-well plates at a density of 5×10^5 cells per well and allow them to adhere overnight.
- Treatment: Prepare a stock solution of **SHP2-D26** in DMSO. Dilute the stock solution in culture medium to final concentrations ranging from 0.1 μ M to 10 μ M. Replace the culture medium with the medium containing **SHP2-D26** or vehicle (DMSO) control.
- Incubation: Incubate the treated cells for 24, 48, or 72 hours.

Protein Extraction

- Washing: After incubation, aspirate the medium and wash the cells twice with ice-cold Phosphate-Buffered Saline (PBS).
- Lysis: Add 100-200 μ L of ice-cold RIPA lysis buffer supplemented with protease and phosphatase inhibitors to each well.
- Scraping and Collection: Scrape the cells and transfer the lysate to a pre-chilled microcentrifuge tube.
- Incubation: Incubate the lysate on ice for 30 minutes with vortexing every 10 minutes.
- Centrifugation: Centrifuge the lysate at 14,000 x g for 15 minutes at 4°C.
- Supernatant Collection: Carefully transfer the supernatant (containing the soluble protein fraction) to a new pre-chilled tube.

Protein Quantification

Determine the total protein concentration of each lysate using a Bicinchoninic Acid (BCA) protein assay kit according to the manufacturer's instructions. Normalize all samples to the same protein concentration using lysis buffer.

Protocol 1: Western Blotting

This method provides semi-quantitative to quantitative data on SHP2 protein levels.

- **Sample Preparation:** Mix 20-30 µg of total protein from each sample with 4x Laemmli sample buffer and boil at 95°C for 5 minutes.
- **SDS-PAGE:** Load the samples onto a 10% SDS-polyacrylamide gel and perform electrophoresis until the dye front reaches the bottom of the gel.
- **Protein Transfer:** Transfer the separated proteins to a polyvinylidene difluoride (PVDF) membrane.
- **Blocking:** Block the membrane with 5% non-fat dry milk or Bovine Serum Albumin (BSA) in Tris-buffered saline with 0.1% Tween 20 (TBST) for 1 hour at room temperature.
- **Primary Antibody Incubation:** Incubate the membrane with a primary antibody specific for total SHP2 (e.g., 1:1000 dilution) overnight at 4°C with gentle agitation. A loading control antibody (e.g., β-actin or GAPDH, 1:5000) should also be used for normalization.
- **Washing:** Wash the membrane three times for 10 minutes each with TBST.
- **Secondary Antibody Incubation:** Incubate the membrane with an appropriate HRP-conjugated secondary antibody (e.g., anti-rabbit IgG-HRP, 1:5000) for 1 hour at room temperature.
- **Detection:** Detect the chemiluminescent signal using an enhanced chemiluminescence (ECL) substrate and an imaging system.
- **Quantification:** Quantify the band intensities using densitometry software (e.g., ImageJ). Normalize the SHP2 band intensity to the corresponding loading control band intensity.

Protocol 2: ELISA (Enzyme-Linked Immunosorbent Assay)

This method provides a quantitative measurement of SHP2 protein concentration. A sandwich ELISA kit for human SHP2 is recommended.

- **Reagent Preparation:** Prepare all reagents, standards, and samples as directed in the ELISA kit manual.
- **Standard Curve:** Prepare a serial dilution of the SHP2 protein standard to generate a standard curve.
- **Sample Addition:** Add 100 μ L of each standard and sample (normalized protein lysate) to the appropriate wells of the antibody-coated microplate.
- **Incubation:** Incubate the plate for 2.5 hours at room temperature or overnight at 4°C.
- **Washing:** Wash the wells multiple times with the provided wash buffer.
- **Detection Antibody:** Add the biotinylated detection antibody and incubate for 1 hour at room temperature.
- **Washing:** Repeat the wash steps.
- **Streptavidin-HRP:** Add the HRP-conjugated streptavidin and incubate for 45 minutes at room temperature.
- **Washing:** Repeat the wash steps.
- **Substrate Addition:** Add the TMB substrate and incubate in the dark for 30 minutes.
- **Stop Solution:** Add the stop solution to terminate the reaction.
- **Measurement:** Immediately measure the absorbance at 450 nm using a microplate reader.
- **Calculation:** Calculate the SHP2 concentration in each sample by interpolating the absorbance values from the standard curve.

Data Presentation

The quantitative data obtained from Western blot densitometry and ELISA should be summarized in clear and concise tables.

Table 1: Quantification of SHP2 Protein Levels by Western Blot Densitometry

Treatment Group	SHP2-D26 Conc. (μM)	Normalized SHP2 Intensity (Arbitrary Units)	Fold Change vs. Vehicle
Vehicle (DMSO)	0	1.00 \pm 0.08	1.00
SHP2-D26	0.1	0.95 \pm 0.07	0.95
SHP2-D26	1.0	0.52 \pm 0.05	0.52
SHP2-D26	10.0	0.21 \pm 0.03	0.21

Data are presented as mean \pm standard deviation (n=3). Intensity values are normalized to the loading control (β -actin) and then to the vehicle control.

Table 2: Quantification of SHP2 Protein Levels by ELISA

Treatment Group	SHP2-D26 Conc. (μM)	SHP2 Concentration (ng/mL)	% of Vehicle Control
Vehicle (DMSO)	0	150.2 \pm 12.5	100.0
SHP2-D26	0.1	142.8 \pm 11.3	95.1
SHP2-D26	1.0	78.1 \pm 9.8	52.0
SHP2-D26	10.0	32.5 \pm 5.1	21.6

Data are presented as mean \pm standard deviation (n=3).

Logical Relationship Diagram

The following diagram illustrates the logical relationship between the experimental intervention and the expected outcome.

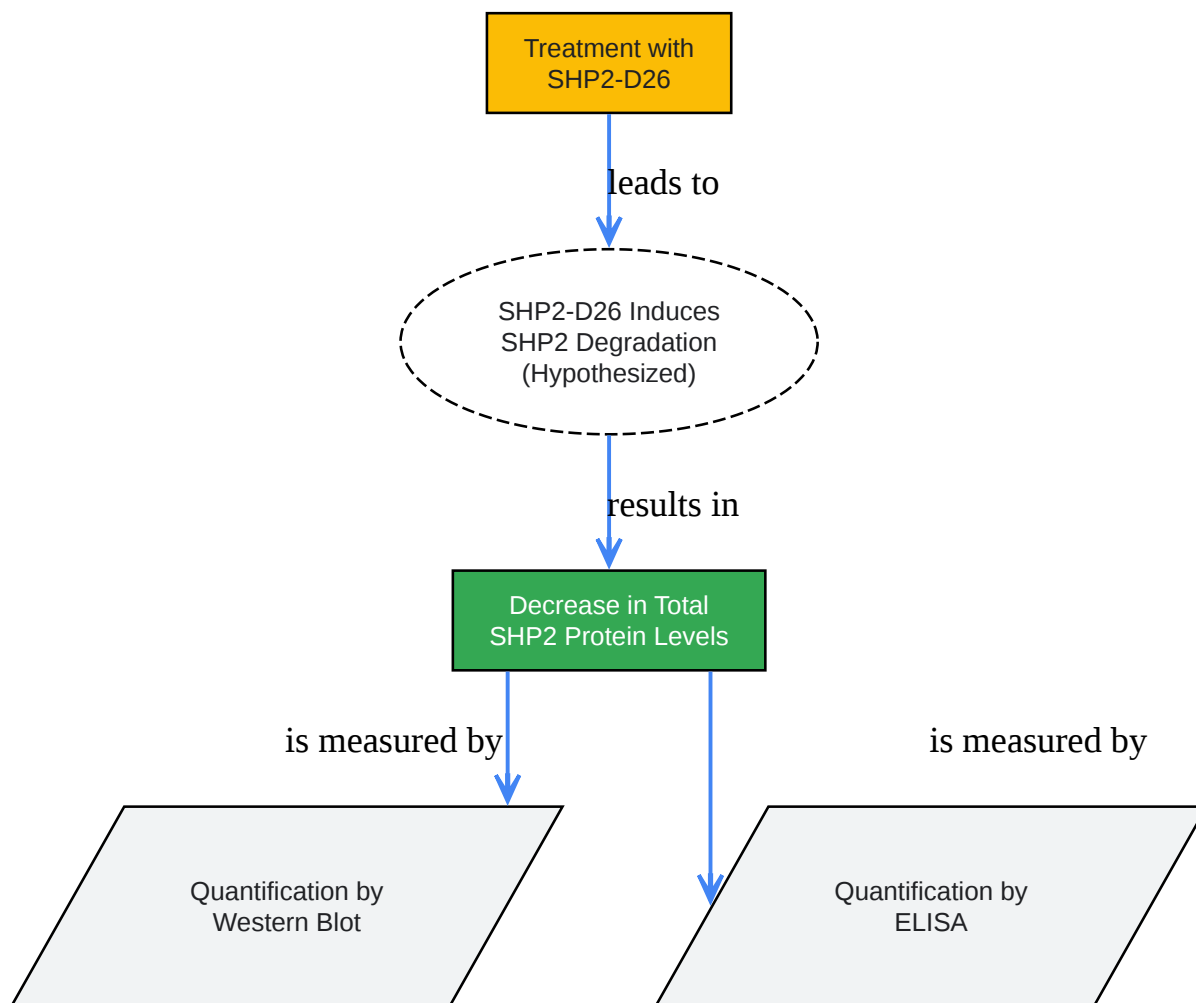

[Click to download full resolution via product page](#)

Caption: Logical flow from **SHP2-D26** treatment to measured outcome.

Conclusion

The protocols described in this application note provide robust and reliable methods for the quantitative measurement of total SHP2 protein levels in cell lysates after treatment with the novel inhibitor **SHP2-D26**. Both Western blotting and ELISA are suitable for this purpose, with ELISA generally offering higher throughput and more precise quantification. The choice of method will depend on the specific experimental needs and available resources. These

protocols are essential for the preclinical evaluation and characterization of SHP2-targeting compounds.

Need Custom Synthesis?

BenchChem offers custom synthesis for rare earth carbides and specific isotopic labeling.

Email: info@benchchem.com or [Request Quote Online](#).

References

- [1. researchgate.net \[researchgate.net\]](#)
- [2. researchgate.net \[researchgate.net\]](#)
- [3. SHP-2 Antibody | Cell Signaling Technology \[cellsignal.com\]](#)
- To cite this document: BenchChem. [Application Note: Quantitative Measurement of SHP2 Protein Levels Following SHP2-D26 Treatment]. BenchChem, [2026]. [Online PDF]. Available at: [<https://www.benchchem.com/product/b15540712/docs#application-note-quantitative-measurement-of-shp2-protein-levels-following-shp2-d26-treatment>]

Disclaimer & Data Validity:

The information provided in this document is for Research Use Only (RUO) and is strictly not intended for diagnostic or therapeutic procedures. While BenchChem strives to provide accurate protocols, we make no warranties, express or implied, regarding the fitness of this product for every specific experimental setup.

Technical Support: The protocols provided are for reference purposes. Unsure if this reagent suits your experiment?

Need Industrial/Bulk Grade? [Request Custom Synthesis Quote](#)

BenchChem

Our mission is to be the trusted global source of essential and advanced chemicals, empowering scientists and researchers to drive progress in science and industry.

Contact

Address: 3281 E Guasti Rd

Ontario, CA 91761, United States

Phone: (601) 213-4426

Email: info@benchchem.com

[Contact our Ph.D. Support Team for a compatibility check](#)