

An In-depth Technical Guide to ER Ligand-5: Chemical Structure and Properties

Author: BenchChem Technical Support Team. **Date:** April 2026

Compound of Interest

Compound Name: *ER ligand-5*

Cat. No.: *B15540852*

[Get Quote](#)

For Researchers, Scientists, and Drug Development Professionals

Introduction

ER ligand-5 is a specific, high-purity chemical compound primarily utilized as a key building block in the synthesis of advanced bi-functional molecules, particularly Proteolysis Targeting Chimeras (PROTACs). Its principal role is to act as the estrogen receptor (ER) targeting moiety, enabling the selective degradation of ER α . This guide provides a comprehensive overview of the chemical structure and known properties of **ER ligand-5**, its application in PROTAC synthesis, and the broader context of its mechanism of action.

Chemical Structure and Properties

While public domain literature and databases do not provide extensive independent characterization of **ER ligand-5**, its identity is well-defined by its CAS number and use in patented chemical syntheses.

Chemical Identity:

- Systematic Name: Not publicly available

- Common Name: **ER ligand-5**
- CAS Number: 2421262-07-7[1]
- Molecular Formula: C₂₈H₂₉NO₂[1]
- Molecular Weight: 411.54 g/mol [1]

Deduced Chemical Structure:

The precise chemical structure of **ER ligand-5** can be deduced from its role as a precursor to PROTAC ER α Degradator-10. By analyzing the structure of the final PROTAC, the components corresponding to the linker and the E3 ligase ligand can be identified, leaving the remaining structure as that of **ER ligand-5**.

(Note: The exact point of attachment for the linker on **ER ligand-5** is inferred from the structure of the final PROTAC.)

Application in PROTAC Synthesis

ER ligand-5 serves as the estrogen receptor-targeting warhead in the synthesis of PROTAC ER α Degradator-10.[1][2][3] PROTACs are heterobifunctional molecules that recruit a target protein (in this case, ER α) to an E3 ubiquitin ligase, leading to the ubiquitination and subsequent degradation of the target protein by the proteasome.

The synthesis of PROTAC ER α Degradator-10 involves chemically linking **ER ligand-5** to a linker molecule, which is then further conjugated to a ligand for an E3 ligase, such as Cereblon.

Experimental Workflow: Synthesis of PROTAC ER α Degradator-10

The following diagram illustrates the general synthetic workflow for creating a PROTAC, such as PROTAC ER α Degradator-10, using **ER ligand-5**.

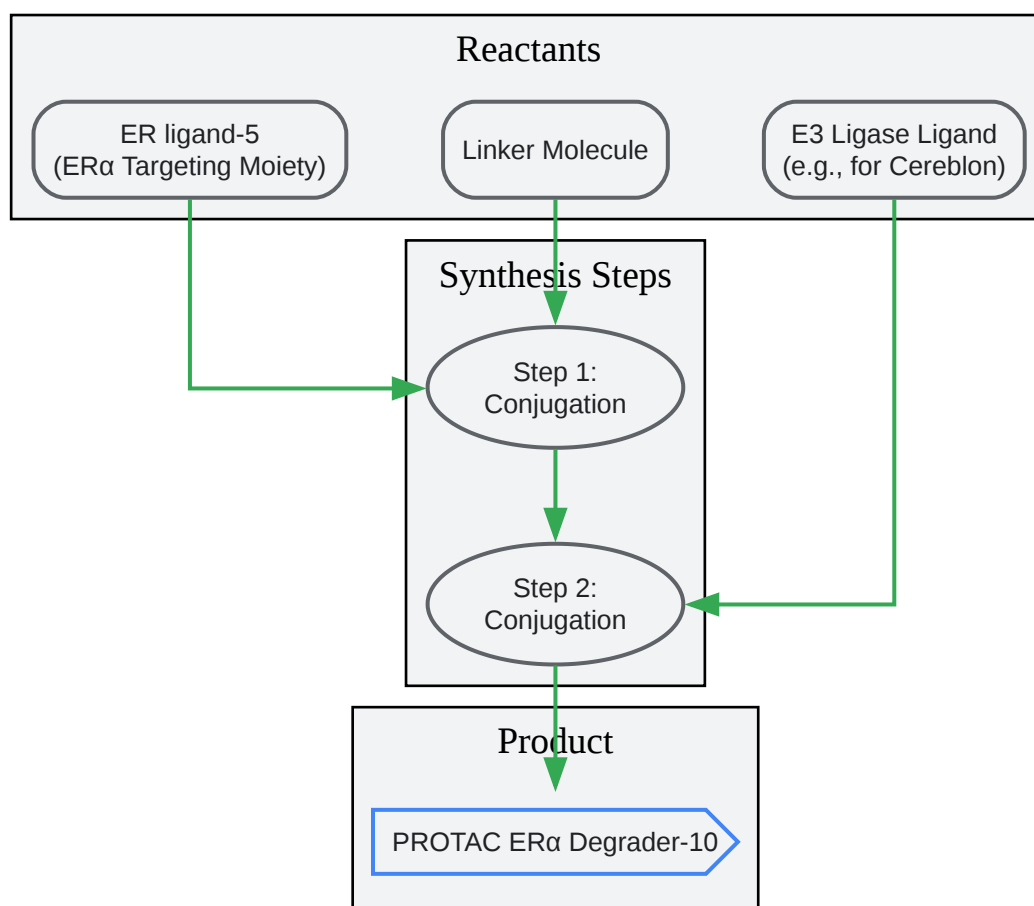

[Click to download full resolution via product page](#)

Caption: General workflow for the synthesis of PROTAC ERα Degradar-10.

Biological Activity and Properties

Specific quantitative biological data for **ER ligand-5**, such as its direct binding affinity (e.g., K_i , K_d , or IC_{50}) to the estrogen receptor, is not readily available in the public domain. The majority of published data focuses on the activity of the final PROTAC molecule, PROTAC ERα Degradar-10.

Properties of PROTAC ERα Degradar-10

Property	Value	Cell Lines	Reference
DC50	0.37 - 1.1 nM	MCF7, T47D, CAMA-1	MedChemExpress

- DC50 is the concentration of the PROTAC that results in 50% degradation of the target protein.

Experimental Protocols

Detailed experimental protocols for assays conducted specifically with **ER ligand-5** are not publicly available. However, standard assays used to characterize ER ligands and PROTACs include:

- **Competitive Binding Assays:** To determine the binding affinity of a ligand for the estrogen receptor, a competitive binding assay is typically performed. This involves incubating the receptor with a labeled ligand (e.g., a fluorescently-tagged estrogen) and varying concentrations of the unlabeled test compound (**ER ligand-5**). The ability of the test compound to displace the labeled ligand is measured, and an IC50 value is calculated.
- **Western Blotting for Protein Degradation:** To measure the degradation of ER α induced by a PROTAC, Western blotting is a standard technique. Cancer cell lines expressing ER α (e.g., MCF-7) are treated with the PROTAC for a specified time. Cell lysates are then prepared, and the proteins are separated by gel electrophoresis, transferred to a membrane, and probed with an antibody specific for ER α . The amount of ER α protein is quantified and compared to untreated controls.
- **Cell Viability Assays:** To assess the downstream functional effect of ER α degradation, cell viability assays (e.g., MTS or CellTiter-Glo) are used. These assays measure the metabolic activity of cells, which is an indicator of cell number and proliferation. A decrease in cell viability upon treatment with the PROTAC would suggest an anti-proliferative effect.

Signaling Pathway

ER ligand-5 functions by binding to the estrogen receptor. The subsequent action depends on the molecule it is part of. As a component of PROTAC ER α Degradation-10, it initiates a degradation pathway. In a hypothetical standalone context as an ER ligand, it would modulate the classical estrogen receptor signaling pathways.

Estrogen Receptor Signaling and PROTAC-Mediated Degradation

The following diagram illustrates the general mechanism of action for an ER α -targeting PROTAC.

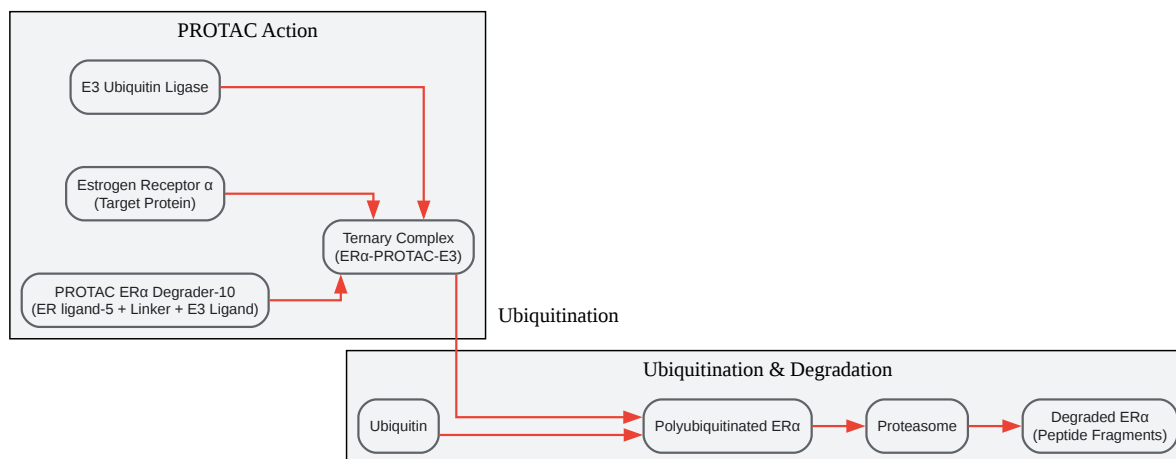

[Click to download full resolution via product page](#)

Caption: Mechanism of PROTAC-mediated degradation of Estrogen Receptor α .

Conclusion

ER ligand-5 is a crucial chemical tool for researchers in the field of targeted protein degradation. While detailed biological data on the ligand itself is limited in the public domain, its role as the ER α -targeting component of PROTAC ER α Degradator-10 is well-established. This guide provides a summary of the available information on its chemical properties and its application in the synthesis of a potent ER α degrader. Further research and publication are needed to fully elucidate the standalone pharmacological profile of **ER ligand-5**.

Need Custom Synthesis?

BenchChem offers custom synthesis for rare earth carbides and specific isotopic labeling.

Email: info@benchchem.com or [Request Quote Online](#).

References

- [1. ER ligand-5 | ER配体 | MCE \[medchemexpress.cn\]](#)
- [2. medchemexpress.com \[medchemexpress.com\]](#)
- [3. medchemexpress.com \[medchemexpress.com\]](#)
- To cite this document: BenchChem. [An In-depth Technical Guide to ER Ligand-5: Chemical Structure and Properties]. BenchChem, [2026]. [Online PDF]. Available at: [\[https://www.benchchem.com/product/b15540852/docs#an-in-depth-technical-guide-to-er-ligand-5-chemical-structure-and-properties\]](https://www.benchchem.com/product/b15540852/docs#an-in-depth-technical-guide-to-er-ligand-5-chemical-structure-and-properties)

Disclaimer & Data Validity:

The information provided in this document is for Research Use Only (RUO) and is strictly not intended for diagnostic or therapeutic procedures. While BenchChem strives to provide accurate protocols, we make no warranties, express or implied, regarding the fitness of this product for every specific experimental setup.

Technical Support: The protocols provided are for reference purposes. Unsure if this reagent suits your experiment?

Need Industrial/Bulk Grade? [Request Custom Synthesis Quote](#)

BenchChem

Our mission is to be the trusted global source of essential and advanced chemicals, empowering scientists and researchers to drive progress in science and industry.

Contact

Address: 3281 E Guasti Rd

Ontario, CA 91761, United States

Phone: (601) 213-4426

Email: info@benchchem.com

Contact our Ph.D. Support Team for a compatibility check