

Physical and chemical properties of quinidine hydrochloride monohydrate

Author: BenchChem Technical Support Team. **Date:** December 2025

Compound of Interest

Compound Name: Quinidine hydrochloride

Cat. No.: B155200

[Get Quote](#)

An In-depth Technical Guide to the Physical and Chemical Properties of **Quinidine Hydrochloride** Monohydrate

Introduction

Quinidine hydrochloride monohydrate is the monohydrochloride, monohydrate salt of quinidine, a Class Ia antiarrhythmic agent and a stereoisomer of the antimalarial drug quinine. [1][2] Originally derived from the bark of the cinchona tree, it has a long history in the management of cardiac arrhythmias.[1] Its primary therapeutic action involves the blockade of multiple cardiac ion channels, which alters the cardiac action potential.[3]

This technical guide provides a comprehensive overview of the core physical and chemical properties of **quinidine hydrochloride** monohydrate. It is intended for researchers, scientists, and drug development professionals, offering detailed data, experimental methodologies, and visual representations of key pathways and workflows to support research, development, and quality control activities.

Core Physical and Chemical Properties

The fundamental identifiers and properties of **quinidine hydrochloride** monohydrate are summarized below.

Property	Value	Source(s)
Chemical Name	(S)-[(2R,4S,5R)-5-ethenyl-1-azabicyclo[2.2.2]octan-2-yl]-(6-methoxyquinolin-4-yl)methanol;hydrate;hydrochloride	[4][5]
Synonyms	Quinidine monohydrochloride monohydrate	[4][6]
CAS Number	6151-40-2	[4][5]
Molecular Formula	C ₂₀ H ₂₇ ClN ₂ O ₃	[4][5][6]
Molecular Weight	378.89 g/mol	[4][5]
Appearance	White to off-white crystalline powder or lustrous needles	[2][4]

Quantitative Physical Data

Quantitative data are critical for formulation, stability, and bioavailability studies. The following tables provide key physical property values for **quinidine hydrochloride** monohydrate.

Table 1: Physicochemical Properties

Property	Value(s)	Conditions	Source(s)
Melting Point	170-175 °C	Not Specified	[4][7]
~172 °C	Not Specified	[4][8]	
pKa	5.4 and 10.0	20°C	[4]
9.05 (Strongest Basic)	Not Specified	[4]	
LogP	3.44	Not Specified	[4]
Specific Optical Rotation	+258°	17°C (in alcohol)	[9]
+230°	15°C (c=1.8 in chloroform)	[9]	

Table 2: Solubility Profile

Solvent	Solubility	Temperature	pH	Source(s)
Water	10 mg/mL (26.39 mM)	25°C	Not Specified	[4]
>56.8 µg/mL	Not Specified	7.4	[5]	
DMSO	76 mg/mL (200.58 mM)	25°C	Not Specified	[4]
Ethanol	76 mg/mL (200.58 mM)	25°C	Not Specified	
Chloroform	1 g in 1.6 mL	Not Specified	Not Specified	[7]
Methanol	Very soluble	Not Specified	Not Specified	[4][7]

Chemical Properties and Mechanism of Action

Quinidine is a dibasic compound whose antiarrhythmic effects stem from its ability to block multiple ion channels within cardiomyocytes.[1][3][4] This multi-channel blockade is the cornerstone of its Class Ia classification.

The primary mechanism of action is the blockade of the fast inward sodium current (INa), which is responsible for the rapid depolarization (Phase 0) of the cardiac action potential.[3][10] This blockade is use-dependent, meaning its effectiveness increases at higher heart rates.[1][3] In addition to its effect on sodium channels, quinidine also blocks several potassium channels (including IKr, IKs, and IK1) and L-type calcium channels (ICaL).[1][3] This combined action prolongs the action potential duration and the QT interval on an electrocardiogram.[1][3] Furthermore, quinidine exhibits anticholinergic (vagolytic) properties by blocking muscarinic M2 receptors.[3]

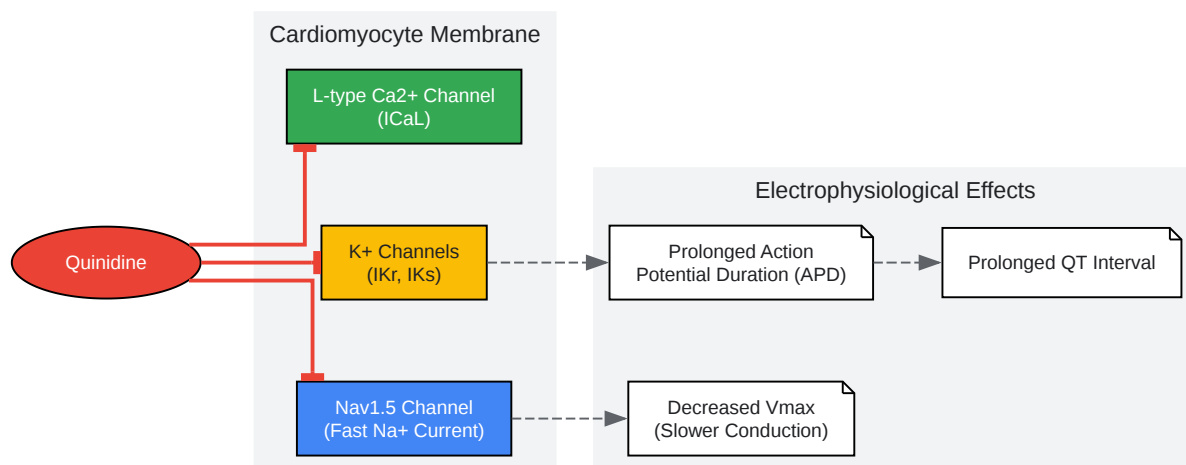

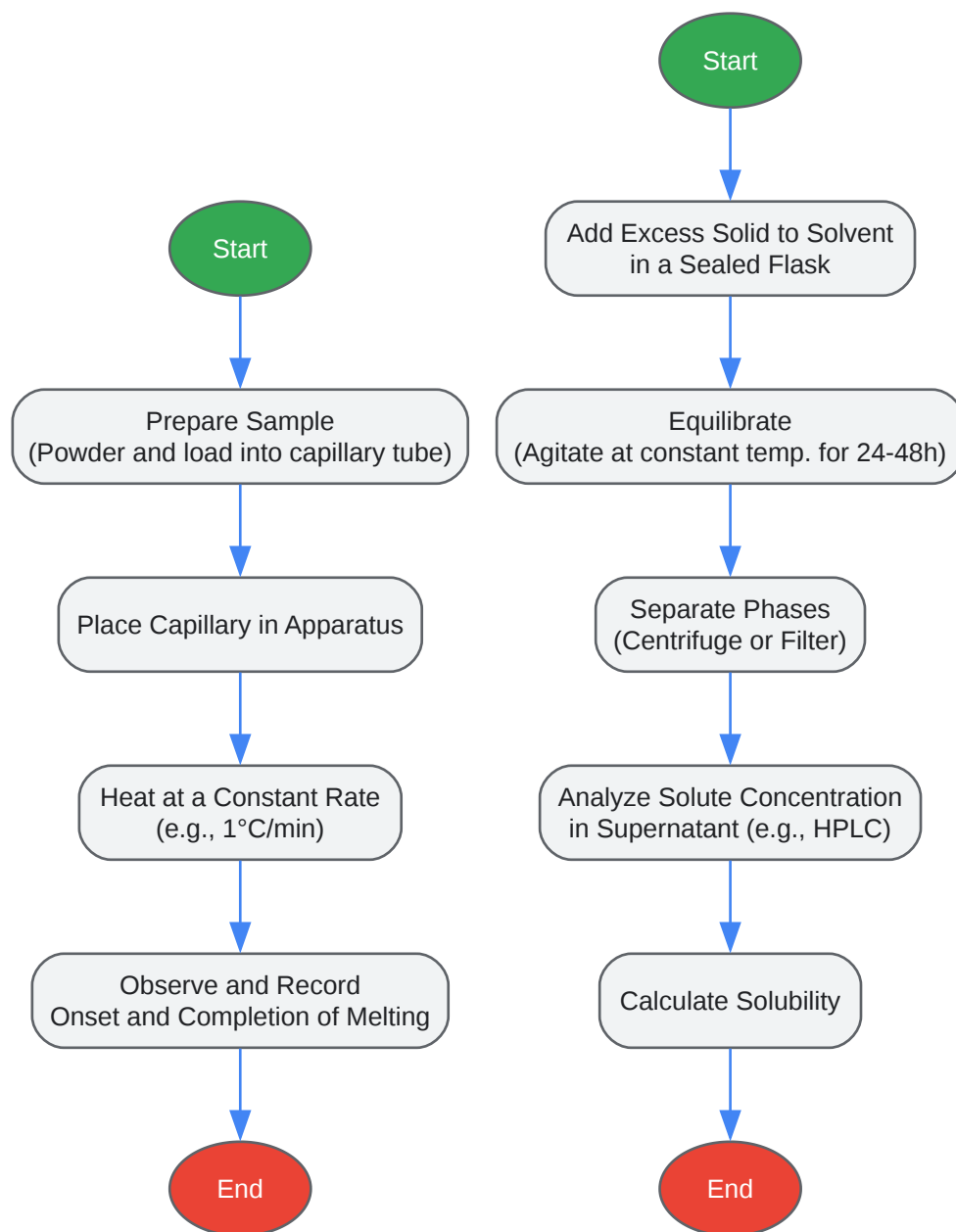

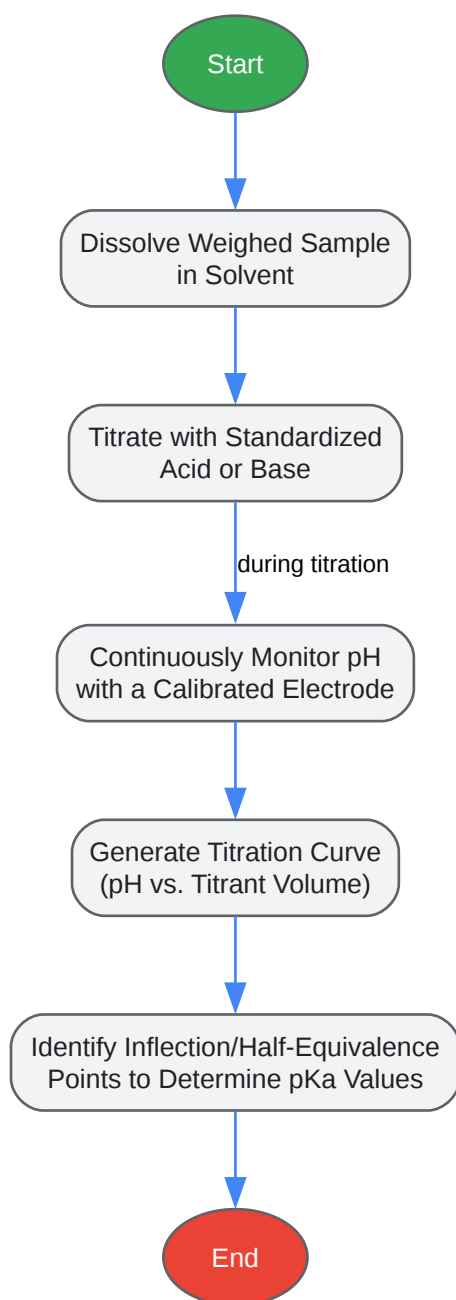

[Click to download full resolution via product page](#)

Need Custom Synthesis?

BenchChem offers custom synthesis for rare earth carbides and specific isotopic labeling.

Email: info@benchchem.com or [Request Quote Online](#).

References

- 1. Quinidine - Wikipedia [en.wikipedia.org]
- 2. CAS 6151-40-2: quinidine hydrochloride monohydrate [cymitquimica.com]
- 3. benchchem.com [benchchem.com]
- 4. benchchem.com [benchchem.com]
- 5. Quinidine hydrochloride monohydrate | C₂₀H₂₇ClN₂O₃ | CID 16219921 - PubChem [pubchem.ncbi.nlm.nih.gov]
- 6. QUINIDINE HYDROCHLORIDE | 6151-40-2 [chemicalbook.com]
- 7. Quinidine | C₂₀H₂₄N₂O₂ | CID 441074 - PubChem [pubchem.ncbi.nlm.nih.gov]
- 8. 56-54-2 · Quinidine · 176-00111[Detail Information] | [Analytical Chemistry]|Laboratory Chemicals-FUJIFILM Wako Pure Chemical Corporation [labchem-wako.fujifilm.com]
- 9. benchchem.com [benchchem.com]
- 10. What is the mechanism of Quinidine Gluconate? [synapse.patsnap.com]
- To cite this document: BenchChem. [Physical and chemical properties of quinidine hydrochloride monohydrate]. BenchChem, [2025]. [Online PDF]. Available at: [https://www.benchchem.com/product/b155200#physical-and-chemical-properties-of-quinidine-hydrochloride-monohydrate]

Disclaimer & Data Validity:

The information provided in this document is for Research Use Only (RUO) and is strictly not intended for diagnostic or therapeutic procedures. While BenchChem strives to provide accurate protocols, we make no warranties, express or implied, regarding the fitness of this product for every specific experimental setup.

Technical Support: The protocols provided are for reference purposes. Unsure if this reagent suits your experiment? [[Contact our Ph.D. Support Team for a compatibility check](#)]

Need Industrial/Bulk Grade? [Request Custom Synthesis Quote](#)

BenchChem

Our mission is to be the trusted global source of essential and advanced chemicals, empowering scientists and researchers to drive progress in science and industry.

Contact

Address: 3281 E Guasti Rd

Ontario, CA 91761, United States

Phone: (601) 213-4426

Email: info@benchchem.com