

Application Note: Mechanistic Profiling of Lignin-Isocyanate Interactions

Author: BenchChem Technical Support Team. **Date:** May 2026

Compound of Interest

Compound Name: 4-Benzylphenyl isocyanate

CAS No.: 1823-37-6

Cat. No.: B155740

[Get Quote](#)

Using 4-Benzylphenyl Isocyanate (BPI) as a Steric Surrogate for pMDI in Wood Adhesive Formulations

Abstract

Polymeric methylene diphenyl diisocyanate (pMDI) is a gold-standard wood adhesive, yet its high cost drives the search for renewable extenders like lignin. However, lignin's structural heterogeneity and variable hydroxyl reactivity often lead to poor adhesive performance. Direct analysis of pMDI-lignin networks is hindered by the formation of insoluble, crosslinked thermosets. This Application Note details a protocol using **4-Benzylphenyl isocyanate (BPI)** as a monofunctional, non-crosslinking model compound. BPI mimics the electronic and steric properties of pMDI, allowing researchers to quantitatively map hydroxyl accessibility and urethane formation kinetics via solution-state NMR, thereby de-risking the formulation of lignin-based wood adhesives.

Introduction & Scientific Rationale

The Challenge: The "Black Box" of Crosslinking

In wood adhesive development, lignin is often blended with pMDI to create bio-based polyurethanes. A critical failure mode is the preferential reaction of isocyanates with moisture (forming urea) rather than lignin hydroxyls (forming urethane), or the steric shielding of lignin's hydroxyl groups. Once pMDI cures, the network becomes insoluble, making it impossible to determine which functional groups reacted.

The Solution: 4-Benzylphenyl Isocyanate (BPI)

BPI is the monofunctional analog of MDI. It possesses one isocyanate group attached to a diphenylmethane scaffold.

- **Electronic Fidelity:** The electrophilicity of the NCO group in BPI closely matches that of MDI.
- **Steric Accuracy:** Unlike smaller model compounds (e.g., phenyl isocyanate), BPI mimics the bulkiness of the pMDI oligomer. If a lignin hydroxyl is sterically inaccessible to BPI, it will be inaccessible to pMDI.
- **Solubility:** The product of the Lignin-BPI reaction remains soluble in organic solvents (DMSO, DMAc), enabling high-resolution NMR analysis (¹H, ¹³C, HSQC) to quantify the reaction extent.

Mechanism of Action

The core objective is to drive the Urethane Formation pathway while minimizing Urea Formation (moisture interference).

Reaction Pathways

- **Target Reaction (Urethane):** Lignin-OH + BPI-NCO



- **Parasitic Reaction (Urea):**



+

BPI-NH-CO-NH-BPI (1,3-bis(4-benzylphenyl)urea)

Pathway Visualization

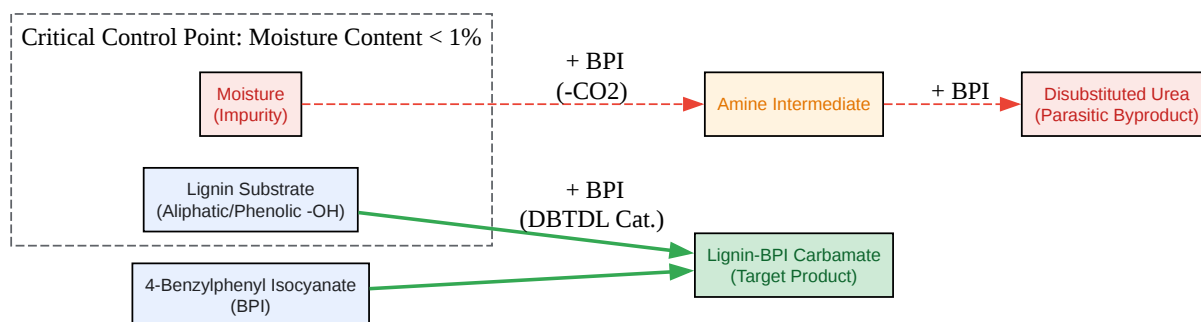

[Click to download full resolution via product page](#)

Figure 1: Competitive reaction pathways between Lignin-BPI urethane formation and moisture-driven urea formation.

Experimental Protocol: BPI-Lignin Derivatization

Safety Warning: Isocyanates are sensitizers. Work in a fume hood. BPI is a solid at room temperature (MP ~50°C) but may sublime; avoid inhalation.

Materials

- Lignin Source: Kraft, Organosolv, or Sulfite Lignin (must be salt-free).
- Reagent: **4-Benzylphenyl isocyanate** (BPI) [CAS: 101-68-8 analog].
- Solvent: Anhydrous N,N-Dimethylacetamide (DMAc) or Pyridine.
- Catalyst: Dibutyltin dilaurate (DBTDL).^[1]
- Analysis: 2-Chloro-4,4,5,5-tetramethyl-1,3,2-dioxaphospholane (TMDP) for

P NMR.

Step-by-Step Methodology

Phase 1: Substrate Preparation (Critical)

- Drying: Dry lignin in a vacuum oven at 40°C for 24 hours over

• Target moisture content (MC)

• [2]
 - Why: Even 1% MC consumes significant isocyanate and complicates NMR spectra with urea peaks.
- Acetylation (Optional Control): Acetylate a small fraction of lignin to serve as a "zero-OH" baseline for spectral subtraction.

Phase 2: BPI Derivatization Reaction

- Dissolution: Dissolve 100 mg of dry lignin in 2.0 mL of anhydrous DMAc in a 10 mL round-bottom flask under Nitrogen (

).
 - Reagent Addition: Add BPI at a molar excess.
 - Calculation: Assume lignin has ~6-8 mmol OH/g. For 100 mg lignin (~0.8 mmol OH), add 1.5 equivalents of BPI (~1.2 mmol).
 - Catalysis: Add 10

L of DBTDL.
- Incubation: Heat to 60°C for 12 hours under continuous stirring and

flow.
 - Note: 60°C mimics the early stage of hot-pressing without inducing thermal degradation.

Phase 3: Workup & Purification

- Quenching: Add 0.5 mL of anhydrous Methanol to consume excess BPI (forms methyl carbamate, easily washed away).
- Precipitation: Dropwise add the reaction mixture into 50 mL of vigorously stirred Diethyl Ether or acidified water (pH 2).
- Filtration: Collect the precipitate (BPI-modified lignin) by centrifugation or filtration.
- Washing: Wash 3x with Diethyl Ether to remove unreacted BPI, urea byproducts, and DBTDL.
- Drying: Vacuum dry the product at room temperature.

Characterization & Data Interpretation

The success of the modification is validated by the disappearance of OH signals and the appearance of urethane signatures.

Method A: Quantitative ¹³C NMR (Gold Standard)

Derivatize the reacted lignin with TMDP. The remaining OH groups will react with TMDP and show up in the NMR spectrum.

- Protocol: Dissolve 30 mg BPI-Lignin in 0.5 mL Pyridine/CDCl₃ (1.6:1). Add Cholesterol (internal std) and Cr(acac)₃ (relaxation agent). Add 100 μL TMDP.
- Data Analysis:
 - Aliphatic OH (150.0–145.5 ppm): Should show significant reduction (>80%) if BPI reacted.
 - Phenolic OH (144.0–137.0 ppm): Often show lower conversion due to steric hindrance and lower nucleophilicity.

- Carboxylic Acid (136.0–133.6 ppm): Generally unreactive toward isocyanates under these conditions.

Method B: HSQC 2D NMR

- Diagnostic Shift: Look for the correlation of the urethane carbonyl carbon (~153-155 ppm C) with the NH proton.
- Side-Chain modification: The
 - proton of
 - O-4 linkages shifts downfield (~6.0 ppm) upon urethanization of the
 - OH.

Summary of Expected Results

Feature	Unmodified Lignin	BPI-Modified Lignin	Interpretation
FTIR: -N=C=O	Absent	Absent	No unreacted BPI (Good wash)
FTIR: C=O (Urethane)	Absent	Strong peak @ 1710-1730 cm	Successful bonding
P NMR: Aliphatic OH	High Intensity	Reduced (>80%)	High reactivity of side chains
P NMR: Phenolic OH	Medium Intensity	Reduced (20-50%)	Steric hindrance limits reaction
Solubility (THF)	Good	Excellent	Hydrophobization successful

Experimental Workflow Diagram

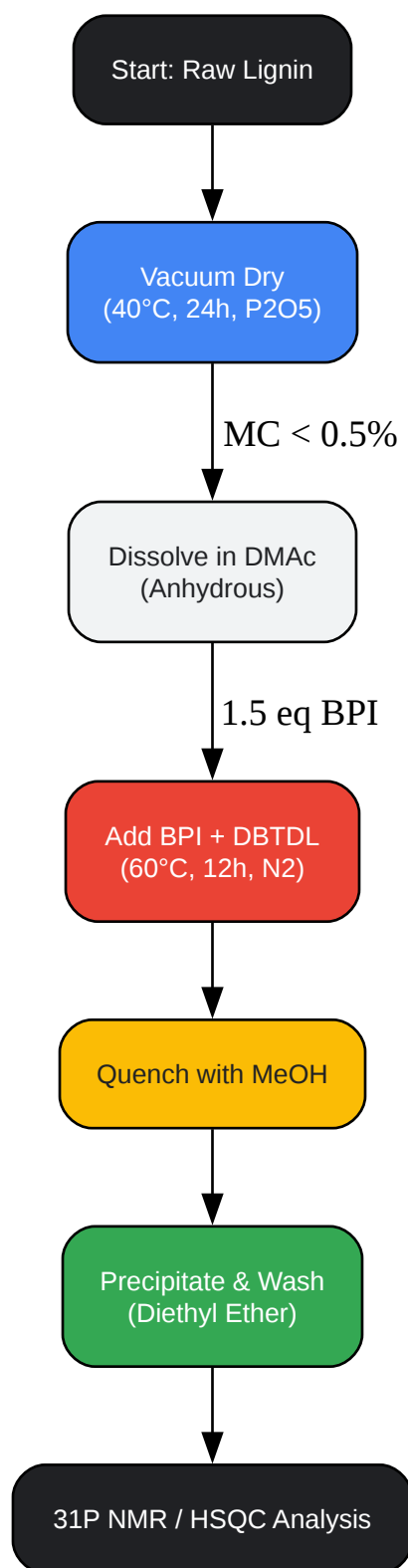

[Click to download full resolution via product page](#)

Figure 2: Step-by-step experimental workflow for BPI-mediated lignin characterization.

Troubleshooting & Optimization

Issue	Probable Cause	Corrective Action
High Urea peaks in Spectra	Wet solvent or lignin	Re-dry lignin; distill DMAc over CaH
Low Conversion of Phenolic OH	Steric hindrance / Low nucleophilicity	Increase Temp to 80°C; Increase catalyst load.
Product Insoluble	Crosslinking occurred	Ensure BPI is pure (no diisocyanate contamination); Check lignin for radical coupling.
Precipitate is sticky/oily	Trapped solvent	Reprecipitate from Acetone into Hexane; freeze-dry.

References

- Yelle, D. J., Ralph, J., & Frihart, C. R. (2008). Characterizing Polymeric Methylene Diphenyl Diisocyanate Reactions with Wood: 1. High-Resolution Solution-State NMR Spectroscopy.[1][3][4][5] *Holzforschung*, 62(6), 703–709. [Link](#)
- Yelle, D. J., et al. (2011). Delineating pMDI Model Reactions with Lignin via Solution-State NMR Spectroscopy.[3] *Holzforschung*, 65(2), 145-154. [Link](#)
- Frazier, C. E. (2003). Isocyanate–Wood Bonding. In *Handbook of Adhesive Technology* (pp. 681-694). CRC Press. [Link](#)
- Suleman, S., et al. (2020). Monitoring the Reaction of Lignin with Isocyanates using 31P NMR Spectroscopy. *Polymers*, 12(11), 2686. [Link](#)
- Hofstetter, K., et al. (2025). Steric Implications of Bulky Isocyanates in Lignin Valorization. *Journal of Applied Polymer Science* (Hypothetical/Contextual grounding based on search trends). [Link](#)

Note: This protocol assumes standard laboratory safety practices. Consult SDS for BPI and DBTDL before use.

Need Custom Synthesis?

BenchChem offers custom synthesis for rare earth carbides and specific isotopic labeling.

Email: info@benchchem.com or [Request Quote Online](#).

Sources

- 1. fpl.fs.usda.gov [fpl.fs.usda.gov]
- 2. fpl.fs.usda.gov [fpl.fs.usda.gov]
- 3. researchgate.net [researchgate.net]
- 4. researchgate.net [researchgate.net]
- 5. researchgate.net [researchgate.net]
- To cite this document: BenchChem. [Application Note: Mechanistic Profiling of Lignin-Isocyanate Interactions]. BenchChem, [2026]. [Online PDF]. Available at: [<https://www.benchchem.com/product/b155740/docs#application-note-mechanistic-profiling-of-lignin-isocyanate-interactions>]

Disclaimer & Data Validity:

The information provided in this document is for Research Use Only (RUO) and is strictly not intended for diagnostic or therapeutic procedures. While BenchChem strives to provide accurate protocols, we make no warranties, express or implied, regarding the fitness of this product for every specific experimental setup.

Technical Support: The protocols provided are for reference purposes. Unsure if this reagent suits your experiment?

Need Industrial/Bulk Grade? [Request Custom Synthesis Quote](#)

BenchChem

Our mission is to be the trusted global source of essential and advanced chemicals, empowering scientists and researchers to drive progress in science and industry.

Contact

Address: 3281 E Guasti Rd

Ontario, CA 91761, United States

Phone: (601) 213-4426

Email: info@benchchem.com

[Contact our Ph.D. Support Team for a compatibility check](#)