

In Vitro Characterization of AT-1001: A Technical Guide for Researchers

Author: BenchChem Technical Support Team. **Date:** May 2026

Compound of Interest

Compound Name: AT 1001
Cat. No.: B15498444

[Get Quote](#)

For Researchers, Scientists, and Drug Development Professionals

This technical guide provides an in-depth overview of the in vitro pharmacological characterization of AT-1001, a high-affinity and selective antagonist of the $\alpha 3\beta 4$ nicotinic acetylcholine receptor (nAChR). The data and protocols compiled herein are intended to serve as a comprehensive resource for professionals in the fields of neuroscience, pharmacology, and drug development.

Introduction

AT-1001 is a novel small molecule that has demonstrated significant potential in preclinical studies. Its primary mechanism of action is the functional antagonism of the $\alpha 3\beta 4$ nAChR, a subtype of nicotinic receptors implicated in various physiological and pathological processes, including nicotine addiction. This guide details the binding affinity, functional potency, and electrophysiological properties of AT-1001, providing a robust dataset for further investigation and development.

Quantitative Data Summary

The following tables summarize the key quantitative parameters of AT-1001's interaction with various nAChR subtypes.

Table 1: Binding Affinity of AT-1001 at nAChR Subtypes

Receptor Subtype	Radioligand	K _i (nM)	Source
α3β4	[³ H]Epibatidine	2.4	[1]
α4β2	[³ H]Epibatidine	476	[1]
α7	[¹²⁵ I]α-Bungarotoxin	221	[1]

Table 2: Functional Activity of AT-1001

Assay Type	Receptor Subtype	Parameter	Value (μM)	Source
Two-Electrode Voltage Clamp	human α3β4	EC ₅₀ (Partial Agonist)	0.37	
Two-Electrode Voltage Clamp	human α4β2	EC ₅₀ (Partial Agonist)	1.5	
Calcium Flux	α3β4	IC ₅₀ (Antagonist)	0.0352	[1]

Experimental Protocols

Detailed methodologies for the key in vitro experiments used to characterize AT-1001 are provided below.

Radioligand Binding Assay

This protocol is for determining the binding affinity (K_i) of AT-1001 to nAChR subtypes expressed in HEK cell membranes.

Materials:

- HEK cells stably expressing the nAChR subtype of interest.

- Radioligand: [³H]Epibatidine for $\alpha 3\beta 4$ and $\alpha 4\beta 2$ subtypes; [¹²⁵I] α -Bungarotoxin for the $\alpha 7$ subtype.[1]
- Test Compound: AT-1001.
- Non-specific Binding Control: A high concentration of a non-labeled nAChR ligand (e.g., 10 μ M nicotine).
- Assay Buffer: 50 mM Tris-HCl, 120 mM NaCl, 5 mM KCl, 2 mM CaCl₂, 1 mM MgCl₂, pH 7.4.
- Wash Buffer: Ice-cold Assay Buffer.
- Glass fiber filters (e.g., Whatman GF/C).
- Scintillation counter.

Procedure:

- Membrane Preparation: Harvest HEK cells and homogenize them in ice-cold Assay Buffer. Centrifuge the homogenate at 48,000 x g for 20 minutes at 4°C. Resuspend the pellet in fresh Assay Buffer and repeat the centrifugation. The final pellet is resuspended in Assay Buffer to a protein concentration of 50-200 μ g per well.
- Assay Setup: In a 96-well plate, set up the following in triplicate:
 - Total Binding: Receptor membranes + Radioligand + Assay Buffer.
 - Non-specific Binding: Receptor membranes + Radioligand + Non-specific Binding Control.
 - Competition: Receptor membranes + Radioligand + varying concentrations of AT-1001.
- Incubation: Incubate the plate at room temperature for 2-3 hours to reach equilibrium.
- Filtration: Terminate the assay by rapid vacuum filtration through glass fiber filters pre-soaked in 0.3% polyethyleneimine. Wash the filters three times with ice-cold Wash Buffer.
- Quantification: Place the filters in scintillation vials with a scintillation cocktail and quantify the bound radioligand using a scintillation counter.

- Data Analysis: Calculate the IC_{50} value from the competition curve and then determine the K_i value using the Cheng-Prusoff equation.

Two-Electrode Voltage Clamp (TEVC) in Xenopus Oocytes

This protocol is for the functional characterization of AT-1001 at nAChRs expressed in Xenopus oocytes.

Materials:

- Xenopus laevis oocytes.
- cRNA for the nAChR subunits of interest.
- Recording Solution (ND96): 96 mM NaCl, 2 mM KCl, 1.8 mM $CaCl_2$, 1 mM $MgCl_2$, 5 mM HEPES, pH 7.5.
- Two-electrode voltage-clamp setup.
- Glass microelectrodes (0.5-2 M Ω resistance) filled with 3 M KCl.

Procedure:

- Oocyte Preparation and Injection: Surgically remove oocytes from a female Xenopus laevis and treat with collagenase to defolliculate. Inject each oocyte with cRNA encoding the desired nAChR subunits and incubate for 2-7 days at 16-18°C.
- Electrophysiological Recording: Place an oocyte in the recording chamber and perfuse with ND96 solution. Impale the oocyte with two microelectrodes for voltage clamping and current injection. Clamp the membrane potential at a holding potential of -70 mV.
- Compound Application: Apply acetylcholine (ACh) or another suitable agonist at its EC_{50} concentration to elicit a baseline current. To test for antagonist activity, pre-apply varying concentrations of AT-1001 for a set duration before co-applying with the agonist.

- **Data Acquisition and Analysis:** Record the changes in membrane current. Construct concentration-response curves to determine the EC_{50} for agonist activity or the IC_{50} for antagonist activity.

Whole-Cell Patch-Clamp Electrophysiology in HEK Cells

This protocol details the investigation of AT-1001's effect on nAChR-mediated currents in HEK cells.

Materials:

- HEK293 cells stably or transiently expressing the nAChR subtype of interest.
- External Solution (in mM): 140 NaCl, 2.8 KCl, 2 CaCl₂, 2 MgCl₂, 10 HEPES, 10 Glucose, pH 7.4.
- Internal (Pipette) Solution (in mM): 140 KCl, 2 MgCl₂, 10 HEPES, 1 EGTA, 2 ATP-Mg, 0.3 GTP-Na, pH 7.2.
- Patch-clamp amplifier and data acquisition system.
- Borosilicate glass pipettes (3-5 M Ω resistance).

Procedure:

- **Cell Preparation:** Culture HEK cells on glass coverslips.
- **Recording:** Transfer a coverslip to the recording chamber and perfuse with the external solution. Establish a whole-cell patch-clamp configuration on a selected cell. Clamp the membrane potential at -60 mV.
- **Compound Application:** Apply a known concentration of an nAChR agonist (e.g., acetylcholine) to elicit a control inward current. To assess antagonist activity, pre-incubate the cell with varying concentrations of AT-1001 before co-application with the agonist.
- **Data Analysis:** Measure the peak amplitude of the agonist-evoked currents in the absence and presence of AT-1001. Generate concentration-response curves to calculate the IC_{50} .

Calcium Flux Assay

This assay measures the ability of AT-1001 to inhibit agonist-induced calcium influx through nAChRs.

Materials:

- HEK cells expressing the nAChR of interest.
- Black-walled, clear-bottom 96-well plates.
- Calcium-sensitive fluorescent dye (e.g., Fluo-4 AM).
- Assay Buffer (e.g., Hanks' Balanced Salt Solution - HBSS).
- Fluorescence plate reader.

Procedure:

- **Cell Plating and Dye Loading:** Plate cells in the 96-well plate and allow them to adhere. Load the cells with the calcium-sensitive dye according to the manufacturer's protocol.
- **Assay:** Wash the cells with Assay Buffer. Acquire a baseline fluorescence reading. Add varying concentrations of AT-1001 to the wells and incubate. Add a pre-determined concentration of an nAChR agonist to all wells and immediately measure the fluorescence intensity over time.
- **Data Analysis:** Calculate the change in fluorescence from baseline. A decrease in the agonist-induced calcium signal in the presence of AT-1001 indicates antagonist activity. Determine the IC_{50} from the concentration-response curve.

Visualizations

The following diagrams illustrate key concepts and workflows related to the in vitro characterization of AT-1001.

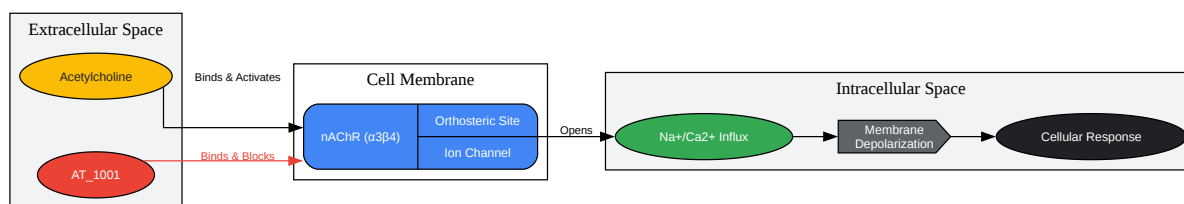

[Click to download full resolution via product page](#)

Caption: Simplified signaling pathway of nAChR activation and antagonism by AT-1001.

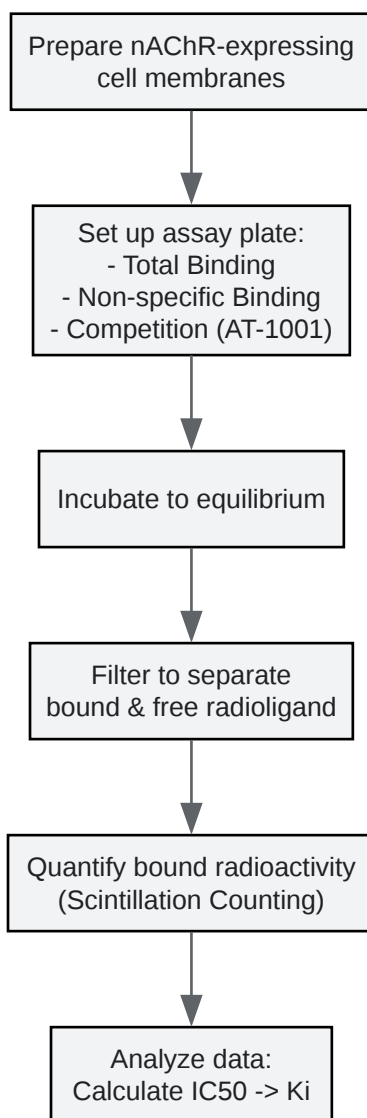

[Click to download full resolution via product page](#)

Caption: Experimental workflow for the radioligand binding assay.

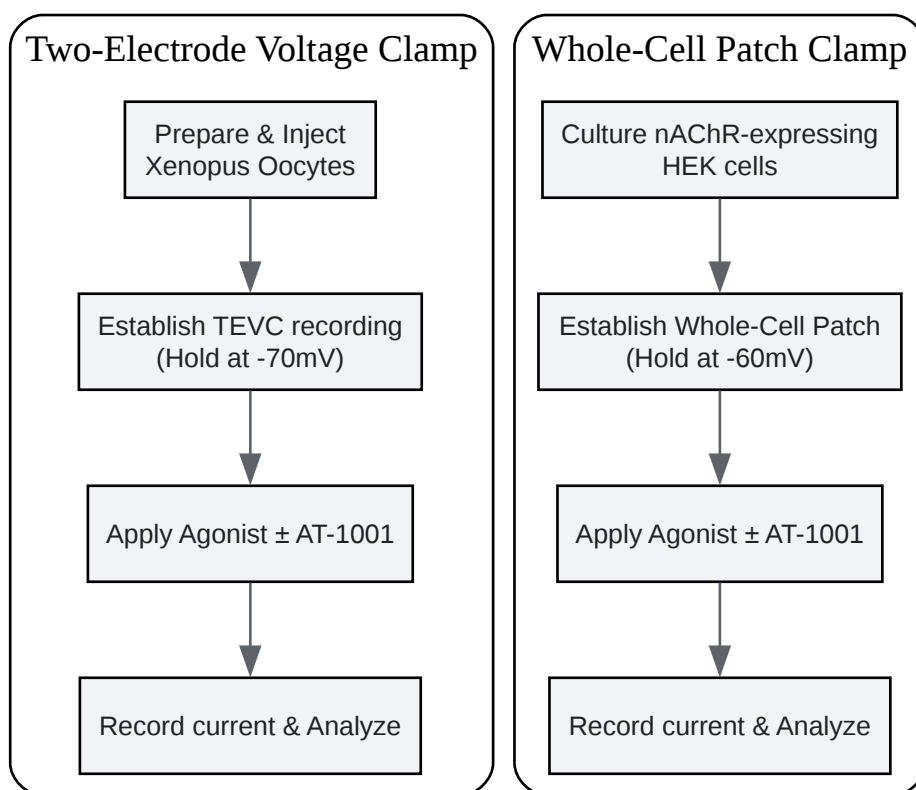

[Click to download full resolution via product page](#)

Caption: General experimental workflows for electrophysiological characterization.

Need Custom Synthesis?

BenchChem offers custom synthesis for rare earth carbides and specific isotopic labeling.

Email: info@benchchem.com or [Request Quote Online](#).

References

- 1. [benchchem.com](https://www.benchchem.com) [benchchem.com]
- To cite this document: BenchChem. [In Vitro Characterization of AT-1001: A Technical Guide for Researchers]. BenchChem, [2026]. [Online PDF]. Available at: [\[https://www.benchchem.com/product/b15498444/docs#in-vitro-characterization-of-at-1001-a-technical-guide-for-researchers\]](https://www.benchchem.com/product/b15498444/docs#in-vitro-characterization-of-at-1001-a-technical-guide-for-researchers)

Disclaimer & Data Validity:

The information provided in this document is for Research Use Only (RUO) and is strictly not intended for diagnostic or therapeutic procedures. While BenchChem strives to provide accurate protocols, we make no warranties, express or implied, regarding the fitness of this product for every specific experimental setup.

Technical Support: The protocols provided are for reference purposes. Unsure if this reagent suits your experiment?

Need Industrial/Bulk Grade? [Request Custom Synthesis Quote](#)

BenchChem

Our mission is to be the trusted global source of essential and advanced chemicals, empowering scientists and researchers to drive progress in science and industry.

Contact

Address: 3281 E Guasti Rd
Ontario, CA 91761, United States
Phone: (601) 213-4426
Email: info@benchchem.com

[Contact our Ph.D. Support Team for a compatibility check](#)