

An In-depth Technical Guide to the Quantum Yield and Photostability of DMHBO+

Author: BenchChem Technical Support Team. **Date:** April 2026

Compound of Interest

Compound Name: DMHBO+
Cat. No.: B15497292

[Get Quote](#)

For researchers, scientists, and professionals in drug development, the selection of appropriate fluorescent probes is paramount for the accuracy and reliability of experimental outcomes. 3,5-dimethoxy-4-hydroxybenzylidene-2-imidazolinone (**DMHBO+**), a fluorophore that exhibits a large Stokes shift upon binding to the Chili RNA aptamer, has emerged as a valuable tool for RNA imaging. This guide provides a comprehensive overview of the quantum yield and photostability of **DMHBO+**, complete with detailed experimental protocols and a workflow for its application.

Quantitative Photophysical Properties of DMHBO+

The fluorescence quantum yield (Φ) is a critical parameter that defines the efficiency of a fluorophore in converting absorbed light into emitted light. For **DMHBO+**, this property is highly dependent on its binding state. The free **DMHBO+** chromophore possesses a very low quantum yield and a brief lifetime of only 17 picoseconds.[1] However, upon binding to the Chili RNA aptamer, its fluorescence is significantly enhanced.

Property	Value	Conditions
Quantum Yield (Φ)	0.10	Bound to Chili RNA aptamer
Excitation Maximum (λ_{ex})	456 nm	Bound to Chili RNA aptamer[1]
Emission Maximum (λ_{em})	592 nm	Bound to Chili RNA aptamer
Molar Extinction Coefficient (ϵ)	22,000 M ⁻¹ cm ⁻¹	Bound to Chili RNA aptamer
Brightness ($\epsilon \times \Phi$)	2,200 M ⁻¹ cm ⁻¹	Bound to Chili RNA aptamer
Stokes Shift	136 nm	Bound to Chili RNA aptamer[1]

Photostability of DMHBO+

Photostability, the resistance of a fluorophore to photodegradation upon exposure to light, is crucial for applications requiring prolonged or intense illumination, such as live-cell imaging and single-molecule tracking. While a specific photobleaching quantum yield for **DMHBO+** is not readily available in the literature, the Chili-**DMHBO+** complex has been described as having high photostability, a desirable characteristic for a fluorescent probe.[2] The photobleaching of similar RNA-fluorophore complexes, like those involving DFHBI, is known to occur through cis-trans photoisomerization.

Parameter	Value/Description	Conditions
Photostability	Qualitatively described as high	When bound to the Chili aptamer[2]
Photobleaching Quantum Yield	Data not available	-
Photobleaching Half-life	Data not available	-

Experimental Protocols

Determination of Fluorescence Quantum Yield (Comparative Method)

The relative fluorescence quantum yield of a sample can be determined by comparing its fluorescence intensity to that of a standard with a known quantum yield.

1. Materials and Instruments:

- Spectroscopic grade solvents
- Standard fluorophore with a known quantum yield in the same spectral region as **DMHBO+** (e.g., Rhodamine 6G, $\Phi = 0.95$)
- UV-Vis spectrophotometer
- Fluorometer
- 10 mm path length quartz cuvettes

2. Sample Preparation:

- Prepare a series of dilute solutions of both the **DMHBO+** complex and the standard in the same solvent.
- The absorbance of the solutions at the excitation wavelength should be kept below 0.1 to avoid inner filter effects.

3. Measurement:

- Record the absorbance spectra of all solutions using the UV-Vis spectrophotometer.
- Measure the fluorescence emission spectra of all solutions using the fluorometer, exciting at the same wavelength for both the sample and the standard.
- Measure the fluorescence of a solvent blank and subtract it from the sample and standard spectra.

4. Data Analysis:

- Integrate the area under the corrected fluorescence emission spectra for both the sample and the standard.
- Plot the integrated fluorescence intensity versus absorbance for both the **DMHBO+** complex and the standard.

- The quantum yield of the **DMHBO+** complex (Φ_X) is calculated using the following equation:

$$\Phi_X = \Phi_{ST} * (\text{Grad}_X / \text{Grad}_{ST}) * (\eta_X^2 / \eta_{ST}^2)$$

Where:

- Φ_{ST} is the quantum yield of the standard.
- Grad_X and Grad_{ST} are the gradients of the linear plots of integrated fluorescence intensity versus absorbance for the sample and the standard, respectively.
- η_X and η_{ST} are the refractive indices of the sample and standard solutions, respectively (if the same solvent is used, this term is 1).

Photostability Assessment

This protocol describes a method to quantify the photostability of the Chili-**DMHBO+** complex under continuous illumination, similar to methods used for other RNA-fluorophore complexes.

1. Materials and Instruments:

- Chili RNA aptamer and **DMHBO+**
- Buffer solution (e.g., 40 mM HEPES pH 7.5, 125 mM KCl, 5 mM MgCl₂)
- Epifluorescence microscope with a suitable filter set for **DMHBO+** and a camera
- Immersion oil

2. Sample Preparation:

- Prepare a solution of the Chili-**DMHBO+** complex by incubating the Chili RNA aptamer with **DMHBO+**.
- Emulsify the solution in microscope immersion oil to create fluorescent aqueous droplets.

3. Measurement:

- Image the fluorescent droplets under continuous illumination using the epifluorescence microscope at full power.
- Acquire a time-lapse series of images until the fluorescence intensity has significantly decreased.

4. Data Analysis:

- Measure the fluorescence intensity of individual droplets in each frame of the time-lapse series.
- Normalize the fluorescence intensity of each droplet to its initial intensity.
- Average the normalized bleaching curves from multiple droplets.
- The photobleaching half-life can be determined from the resulting decay curve. The photobleaching quantum yield (Φ_b) can be calculated if the photon flux is known, using the formula:

$$\Phi_b = (\text{number of photobleached molecules}) / (\text{total number of absorbed photons})$$

Application Workflow: RNA Imaging with Chili-DMHBO+

DMHBO+ is not involved in a biological signaling pathway itself but is a tool to visualize RNA molecules that have been tagged with the Chili aptamer. The workflow for its use in cellular RNA imaging is depicted below.

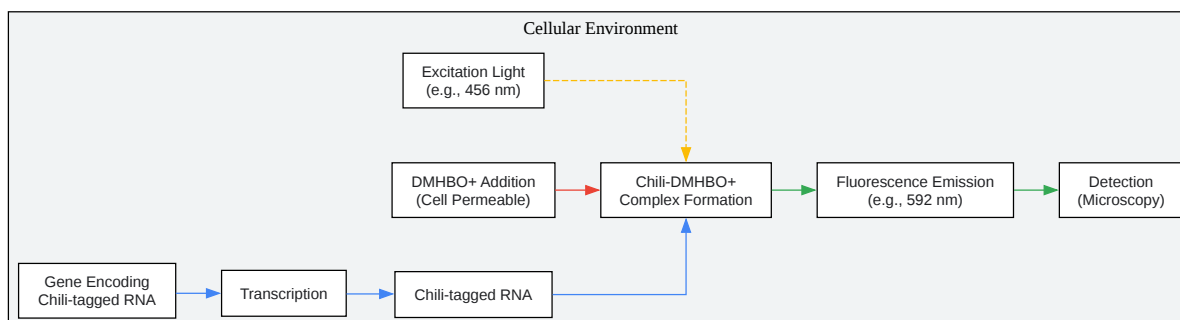

[Click to download full resolution via product page](#)

Workflow for cellular RNA imaging using the Chili-**DMHBO+** system.

This workflow illustrates the process from the transcription of a Chili aptamer-tagged RNA within a cell to the detection of its fluorescence upon binding of exogenously added **DMHBO+**. The formation of the Chili-**DMHBO+** complex leads to a significant increase in fluorescence, allowing for the visualization and tracking of the target RNA molecule.

Need Custom Synthesis?

BenchChem offers custom synthesis for rare earth carbides and specific isotopic labeling.

Email: info@benchchem.com or [Request Quote Online](#).

References

- 1. [Imaging RNA polymerase III transcription using a photostable RNA-fluorophore complex - PMC \[pmc.ncbi.nlm.nih.gov\]](#)
- 2. [Making sure you're not a bot! \[opus4.kobv.de\]](#)

- To cite this document: BenchChem. [An In-depth Technical Guide to the Quantum Yield and Photostability of DMHBO+]. BenchChem, [2026]. [Online PDF]. Available at: [\[https://www.benchchem.com/product/b15497292/docs#an-in-depth-technical-guide-to-the-quantum-yield-and-photostability-of-dmhbo\]](https://www.benchchem.com/product/b15497292/docs#an-in-depth-technical-guide-to-the-quantum-yield-and-photostability-of-dmhbo)

Disclaimer & Data Validity:

The information provided in this document is for Research Use Only (RUO) and is strictly not intended for diagnostic or therapeutic procedures. While BenchChem strives to provide accurate protocols, we make no warranties, express or implied, regarding the fitness of this product for every specific experimental setup.

Technical Support: The protocols provided are for reference purposes. Unsure if this reagent suits your experiment?

Need Industrial/Bulk Grade? [Request Custom Synthesis Quote](#)

BenchChem

Our mission is to be the trusted global source of essential and advanced chemicals, empowering scientists and researchers to drive progress in science and industry.

Contact

Address: 3281 E Guasti Rd
Ontario, CA 91761, United States
Phone: (601) 213-4426
Email: info@benchchem.com

[Contact our Ph.D. Support Team for a compatibility check](#)