

Technical Support Center: Nitration of 3-Chlorobenzoic Acid

Author: BenchChem Technical Support Team. **Date:** February 2026

Compound of Interest

Compound Name: 3-Chloro-4,5-dinitrobenzoic acid

CAS No.: 609-75-6

Cat. No.: B15493375

[Get Quote](#)

Optimization, Troubleshooting, and Yield Enhancement Guide

Executive Summary & Mechanistic Insight

The nitration of 3-chlorobenzoic acid is a classic yet challenging Electrophilic Aromatic Substitution (EAS). The core difficulty lies in the conflicting directing effects of the substituents, which directly impacts yield and purification efficiency.

- The Conflict:
 - -COOH (C1): A strong electron-withdrawing group (EWG) and a meta-director. It deactivates the ring and directs incoming electrophiles to position C5.
 - -Cl (C3): A weak EWG but an ortho/para-director (due to lone pair resonance). It directs incoming electrophiles to C2, C4, and C6.

The "Winning" Director: In systems with competing directing groups, the ortho/para director (Chlorine) generally controls the orientation, even if it is deactivating. Consequently, the major thermodynamic product is 2-nitro-5-chlorobenzoic acid (formed by attack at C6, para to the chlorine), followed by the minor isomer 4-nitro-3-chlorobenzoic acid (attack at C4, ortho to chlorine).

Note: The formation of the meta-product (5-nitro-3-chlorobenzoic acid) is negligible because the -COOH group strongly deactivates the ring, and the -Cl group does not stabilize the transition state for attack at C5.

Reaction Pathway Visualization

The following diagram illustrates the competitive pathways and the formation of the major product.

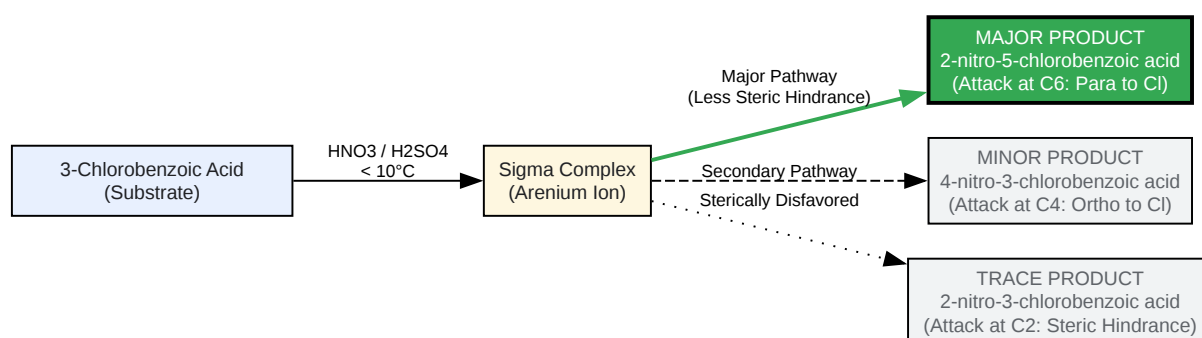

[Click to download full resolution via product page](#)

Figure 1: Reaction pathways for the nitration of 3-chlorobenzoic acid. The major product results from attack para to the chlorine atom.

Troubleshooting Guide (Q&A)

This section addresses specific failure modes reported by users in the field.

Category: Yield & Selectivity

Q1: My isolated yield is stuck at ~55-60%, but the starting material is consumed. Where is the rest of the mass? A: This is likely a regioisomer solubility issue during workup.

- Root Cause: The nitration produces a mixture of isomers (approx. 65:30 ratio of 6-nitro to 4-nitro isomers). If you are recrystallizing from water or ethanol, the minor isomers often remain in the mother liquor, which is good for purity but "bad" for crude yield calculation.
- Solution:

- Quench Protocol: Pour the reaction mixture onto crushed ice (not water) to maximize precipitation of all isomers.
- Mother Liquor Recovery: Neutralize the filtrate to pH 3-4 to precipitate remaining organic acids.
- Verification: Run HPLC on the crude reaction mass before workup to establish the true conversion yield vs. isolated yield.

Q2: I am seeing significant amounts of dinitrated species (3-chloro-2,6-dinitrobenzoic acid). How do I stop this? A: Dinitration occurs when the reaction temperature spikes or when local concentration of HNO₃ is too high.^[1]

- Mechanism: Once the first nitro group is added, the ring is severely deactivated (approx. times slower). However, at temperatures >40°C or with excess nitrating agent, a second nitration can force its way onto the ring.
- Corrective Action:
 - Temperature Control: Maintain internal temperature strictly between 0°C and 10°C during addition.
 - Stoichiometry: Limit HNO₃ to 1.05 - 1.1 equivalents. Do not use a large excess "just to be sure."

Category: Process Safety

Q3: The reaction mixture turned dark brown/black and emitted fumes. What happened? A: This indicates oxidative decomposition, a dangerous runaway condition.

- Root Cause: Rapid addition of HNO₃ caused a localized exotherm. Nitric acid acts as an oxidant rather than a nitrating agent at high temperatures, destroying the aromatic ring and generating gases.
- Immediate Action: Stop addition. Maximize cooling. Do not quench into water immediately if the reaction is violently boiling (risk of steam explosion).

- Prevention: Use a dosing pump for HNO₃ addition and ensure your cooling bath has sufficient capacity (e.g., dry ice/acetone or a cryostat) to handle the heat of reaction (approx. -150 kJ/mol).

Category: Purification[1][2][3][4]

Q4: How can I efficiently separate the 2-nitro-5-chloro isomer from the 4-nitro-3-chloro isomer without column chromatography? A: Exploiting differential solubility in aqueous ethanol is the industry standard.

- Protocol:
 - Dissolve the crude mixture in boiling 20% Ethanol/Water.
 - The 2-nitro-5-chlorobenzoic acid (major product) is significantly less soluble at lower temperatures than the 4-nitro isomer.
 - Cool slowly to 4°C. The crystals formed are typically enriched (>95%) in the major isomer.
 - Note: The 2-isomer has a higher melting point (~165°C) compared to the 4-isomer, aiding in monitoring purification via melting point depression.

Optimized Experimental Protocol

Objective: Synthesis of 2-nitro-5-chlorobenzoic acid (Major Product). Scale: 10g Input (Scalable to 1kg).

Reagents & Equipment

Component	Specification	Quantity	Role
3-Chlorobenzoic Acid	>98% Purity	10.0 g (63.9 mmol)	Substrate
Sulfuric Acid ()	98% Conc.	40 mL	Solvent/Catalyst
Nitric Acid ()	70% Conc.[1] (d=1.41)	4.5 mL (~70 mmol)	Electrophile Source
Ice	Crushed	~150 g	Quenching

Step-by-Step Procedure

- Dissolution (Solvation):
 - In a 250 mL 3-neck round-bottom flask equipped with a thermometer and magnetic stir bar, add 40 mL of conc.
 - Cool the acid to 0–5°C using an ice-salt bath.^[1]
 - Slowly add 10.0 g of 3-chlorobenzoic acid in small portions. Stir until fully dissolved. Note: The solution is viscous; ensure vigorous stirring.
- Nitration (Critical Step):
 - Prepare a "Mixed Acid" solution: Carefully mix 4.5 mL
with 5 mL
(pre-cooled).
 - Add the Mixed Acid dropwise to the reaction flask over 30–45 minutes.
 - CRITICAL: Do not allow the internal temperature to exceed 10°C. If it spikes, stop addition immediately.
- Reaction Completion:
 - After addition, allow the mixture to stir at 0–5°C for 1 hour.
 - Allow the mixture to warm to room temperature (20–25°C) and stir for an additional 1 hour to ensure conversion of the sterically hindered substrate.
- Quench & Isolation:
 - Pour the reaction mixture slowly onto 150 g of crushed ice with vigorous stirring. The product will precipitate as a white/off-white solid.
 - Stir for 20 minutes to break up clumps.

- Filter via vacuum filtration (Buchner funnel).[2]
- Wash the filter cake with 3 x 20 mL cold water to remove residual acid.
- Purification (Recrystallization):
 - Transfer the crude solid to a beaker.
 - Recrystallize from hot Ethanol/Water (1:3 ratio).
 - Filter the crystals and dry in a vacuum oven at 50°C.

Data & Specifications

Property	Major Product	Minor Product
IUPAC Name	2-nitro-5-chlorobenzoic acid	4-nitro-3-chlorobenzoic acid
Structure Origin	Attack at C6 (Para to Cl)	Attack at C4 (Ortho to Cl)
Approx. Yield %	60–70%	20–30%
Melting Point	165–168°C	218–220°C
Solubility (EtOH)	Moderate	High

References

- Morrison, R. T., & Boyd, R. N. (1992). Organic Chemistry (6th ed.). Prentice Hall. (Chapter on Electrophilic Aromatic Substitution: Directing Effects of Halogens).
- Google Patents. (1968). US3397229A: Nitration of benzoic acid and its chlorinated derivatives.[3] [Link](#)
- BenchChem Technical Support. (2025). Identification of byproducts in the nitration of 4-chlorobenzoic acid derivatives. (Referenced for general nitration safety and byproduct profiles). [Link](#)
- Carl Roth. (2024). Safety Data Sheet: 5-Chloro-2-nitrobenzoic acid. [Link](#)
- Study.com. (n.d.). Electrophilic Substitution of 3-Chlorobenzoic Acid. (Confirmed directing group logic). [Link](#)

Disclaimer: This guide is intended for qualified researchers. Always review the specific Safety Data Sheets (SDS) for all chemicals before use. Nitration reactions involve strong acids and potential exotherms.

Need Custom Synthesis?

BenchChem offers custom synthesis for rare earth carbides and specific isotopic labeling.

Email: info@benchchem.com or [Request Quote Online](#).

Sources

- [1. pdf.benchchem.com \[pdf.benchchem.com\]](https://pdf.benchchem.com)
- [2. benchchem.com \[benchchem.com\]](https://www.benchchem.com)
- [3. US3397229A - Nitration of benzoic acid and its chlorinated derivatives - Google Patents \[patents.google.com\]](#)
- [4. cdhfinechemical.com \[cdhfinechemical.com\]](https://www.cdhfinechemical.com)
- To cite this document: BenchChem. [Technical Support Center: Nitration of 3-Chlorobenzoic Acid]. BenchChem, [2026]. [Online PDF]. Available at: [\[https://www.benchchem.com/product/b15493375#optimizing-yield-in-the-nitration-of-3-chlorobenzoic-acid\]](https://www.benchchem.com/product/b15493375#optimizing-yield-in-the-nitration-of-3-chlorobenzoic-acid)

Disclaimer & Data Validity:

The information provided in this document is for Research Use Only (RUO) and is strictly not intended for diagnostic or therapeutic procedures. While BenchChem strives to provide accurate protocols, we make no warranties, express or implied, regarding the fitness of this product for every specific experimental setup.

Technical Support: The protocols provided are for reference purposes. Unsure if this reagent suits your experiment? [[Contact our Ph.D. Support Team for a compatibility check](#)]

Need Industrial/Bulk Grade? [Request Custom Synthesis Quote](#)

BenchChem

Our mission is to be the trusted global source of essential and advanced chemicals, empowering scientists and researchers to drive progress in science and industry.

Contact

Address: 3281 E Guasti Rd

Ontario, CA 91761, United States

Phone: (601) 213-4426

Email: info@benchchem.com