

Technical Comparison Guide: FT-IR Analysis of Thiophene-Based Yrones

Author: BenchChem Technical Support Team. **Date:** April 2026

Compound of Interest

Compound Name: 2-Propyn-1-one, 3-phenyl-1-(2-thienyl)-

CAS No.: 21985-04-6

Cat. No.: B15480739

[Get Quote](#)

Part 1: Executive Summary & Strategic Context

In the landscape of heterocyclic drug development, 3-phenyl-1-(thiophen-2-yl)prop-2-yn-1-one represents a critical "ynone" scaffold. Unlike its ubiquitous "enone" (chalcone) cousins, this acetylenic ketone serves as a high-reactivity intermediate for synthesizing thioflavones, pyrazoles, and sulfur-containing pharmacophores.

This guide provides a rigorous FT-IR spectral analysis, contrasting this target molecule against its two most common structural analogs: the Thieryl Chalcone (alkene analog) and the Diphenyl Ynone (non-heterocyclic analog). By mastering these spectral distinctions, researchers can validate synthesis fidelity and monitor the purity of this electrophilic warhead.

Why This Analysis Matters

- **differentiation:** The C≡C triple bond provides a "silent region" diagnostic peak (~2200 cm⁻¹) absent in chalcones.
- **Thiophene Effect:** The electron-rich thiophene ring lowers carbonyl frequencies via

-conjugation more effectively than phenyl rings, a key indicator of electronic environment.

- Purity Monitoring: The disappearance of precursor aldehydic C-H stretches is the primary metric for reaction completion.

Part 2: Comparative Spectral Analysis

The following data synthesizes experimental baselines from thienyl chalcone derivatives and standard spectroscopic values for conjugated ynones.

Table 1: Spectral Fingerprint Comparison

Functional Group	Target: Thienyl Ynone (3-phenyl-1-(2-thienyl)-2-propyn-1-one)	Alt 1: Thienyl Chalcone (3-phenyl-1-(2-thienyl)-2-propen-1-one)	Alt 2: Diphenyl Ynone (1,3-diphenylprop-2-yn-1-one)	Diagnostic Insight
C≡C Stretch	2190 – 2210 cm ⁻¹ (Med/Weak)	Absent	2200 – 2220 cm ⁻¹	Primary Differentiator. The ynone shows a distinct band in the 2200 region; the chalcone does not.
C=O Stretch	1635 – 1650 cm ⁻¹ (Strong)	1645 cm ⁻¹	1650 – 1665 cm ⁻¹	Thiophene conjugation lowers compared to the all-phenyl analog due to the "thiophene effect" (S-heteroatom donation).
C=C (Alkene)	Absent	1587 cm ⁻¹ (Strong)	Absent	The chalcone's enone doublet is missing in the ynone.
Thiophene Ring	1410 cm ⁻¹ , 720-740 cm ⁻¹	1410 cm ⁻¹ , 720-740 cm ⁻¹	Absent	Confirms the presence of the heterocyclic moiety vs. the all-phenyl analog.

C-H (Aldehydic)	Absent	Absent	Absent	Absence confirms no residual starting material (2-thiophenecarboxaldehyde).
-----------------	--------	--------	--------	---

Deep Dive: The "Thiophene Effect" on Carbonyls

In the target ynone, the carbonyl (C=O) is flanked by a thiophene ring and an alkyne.

- Mechanism: The sulfur atom in thiophene is a strong electron donor via resonance (+M effect). This increases the single-bond character of the adjacent C=O bond, lowering its vibrational frequency (force constant decreases).
- Observation: While a standard conjugated phenyl ketone appears $\sim 1660\text{ cm}^{-1}$, the thienyl substitution pulls this down to $\sim 1635\text{--}1650\text{ cm}^{-1}$. This redshift is a quality control marker; if your C=O peak is $>1660\text{ cm}^{-1}$, you may have failed to couple the thiophene or oxidized the ring.

Part 3: Experimental Protocol (Self-Validating)

This protocol describes the validation of the target ynone synthesized via Sonogashira Coupling or Nucleophilic Addition/Oxidation.

Workflow Diagram: Synthesis Monitoring

The following diagram illustrates the critical decision points in spectral monitoring.

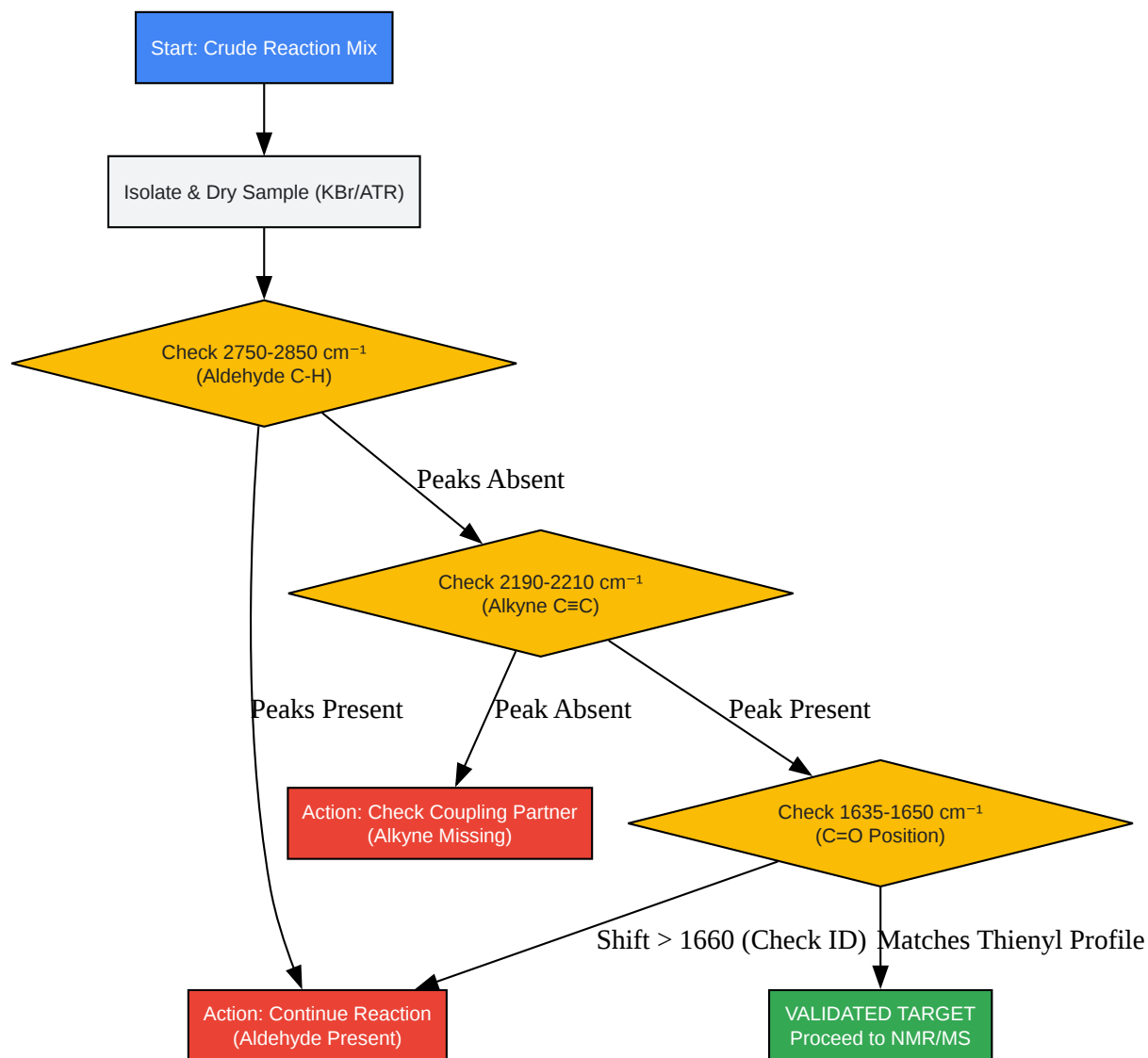

[Click to download full resolution via product page](#)

Caption: Logic flow for validating the conversion of 2-thiophenecarboxaldehyde to 3-phenyl-1-(2-thienyl)-2-propyn-1-one.

Detailed Methodology

Objective: Confirm identity and purity of 3-phenyl-1-(2-thienyl)-2-propyn-1-one.

- Sample Preparation:
 - Solid State (Preferred): Mix 1-2 mg of dry product with 100 mg KBr. Grind to a fine powder and press into a transparent pellet. This prevents solvent interference in the carbonyl region.
 - ATR (Alternative): Ensure the crystal (Diamond/ZnSe) is clean. Apply high pressure to the solid sample to ensure contact. Note: ATR frequencies may be 2-5 cm^{-1} lower than KBr.
- Data Acquisition:
 - Range: 4000 – 400 cm^{-1} .
 - Resolution: 4 cm^{-1} .
 - Scans: 32 (minimum) to resolve weak alkyne bands.
- Validation Steps (The "3-Point Check"):
 - Zone 1 (3100-2800 cm^{-1}): Look for the absence of the "Fermi Doublet" of the aldehyde (2850 & 2750 cm^{-1}). If present, the reaction is incomplete.
 - Zone 2 (2200 cm^{-1}): Confirm the presence of the $\text{C}\equiv\text{C}$ stretch. It should be a sharp, medium-to-weak intensity band. If this is a broad blob, you may have polymerized material.
 - Zone 3 (1650 cm^{-1}): Verify the $\text{C}=\text{O}$ stretch.
 - Target: ~1640 cm^{-1} (Thienyl Ynone).
 - Error Mode: ~1680 cm^{-1} indicates loss of conjugation (broken molecule) or saturated ketone.

Part 4: Spectral Assignment Logic

Understanding why the peaks appear where they do allows for troubleshooting.

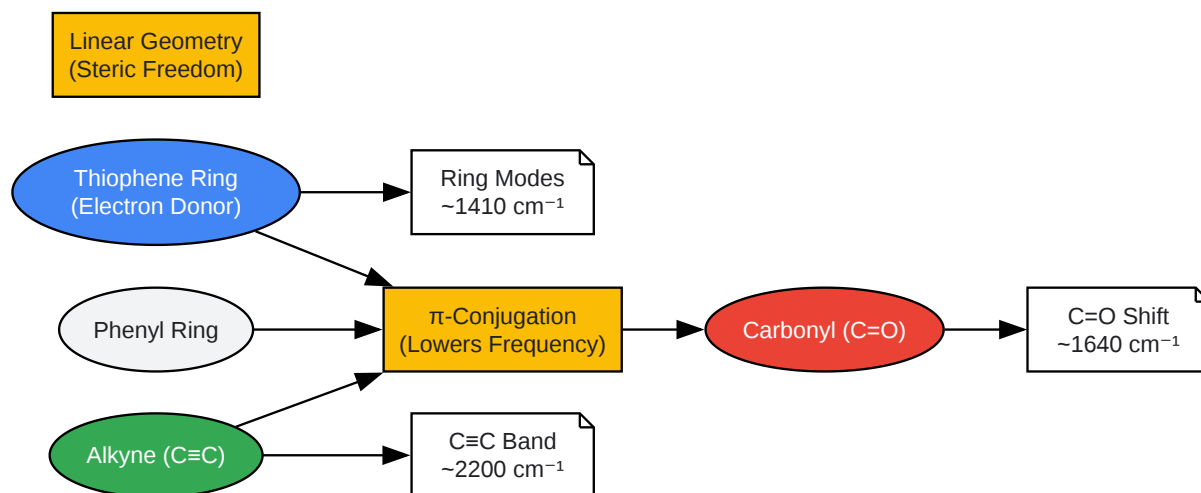

[Click to download full resolution via product page](#)

Caption: Mechanistic influence of thiophene donation and alkyne conjugation on the observed IR spectrum.

References

- Synthesis and Crystal Structure of Thienyl Chalcones: Title: Crystal structure of (2E)-3-[4-(dimethylamino)phenyl]-1-(thiophen-2-yl)prop-2-en-1-one. Source: Acta Crystallographica / NIH. URL:[[Link](#)] (Provides the experimental baseline for the C=O and C=C modes in the closely related enone analog).
- Thioflavone Precursors & NMR/IR Data: Title: Heterocyclic Analogs of Thioflavones: Synthesis and NMR Spectroscopic Investigations. Source: MDPI Molecules. URL:[[Link](#)] (Details the synthesis of 1-(heteroaryl)-3-phenylprop-2-yn-1-ones, confirming the ynone structure and stability).
- Vibrational Analysis of Chalcones: Title: Structural, Vibrational and Electrochemical Analysis of Isomeric Chalcones. Source: MDPI. URL:[[Link](#)] (Provides the comparative basis for assigning phenyl vs. thienyl ring modes).
- To cite this document: BenchChem. [Technical Comparison Guide: FT-IR Analysis of Thiophene-Based Yrones]. BenchChem, [2026]. [Online PDF]. Available at: [<https://www.benchchem.com/product/b15480739/docs#technical-comparison-guide-ft-ir-analysis-of-thiophene-based-yrones>]

Disclaimer & Data Validity:

The information provided in this document is for Research Use Only (RUO) and is strictly not intended for diagnostic or therapeutic procedures. While BenchChem strives to provide accurate protocols, we make no warranties, express or implied, regarding the fitness of this product for every specific experimental setup.

Technical Support: The protocols provided are for reference purposes. Unsure if this reagent suits your experiment?

Need Industrial/Bulk Grade? [Request Custom Synthesis Quote](#)

BenchChem

Our mission is to be the trusted global source of essential and advanced chemicals, empowering scientists and researchers to drive progress in science and industry.

Contact

Address: 3281 E Guasti Rd

Ontario, CA 91761, United States

Phone: (601) 213-4426

Email: info@benchchem.com

[Contact our Ph.D. Support Team for a compatibility check](#)