

A Comparative Guide to the Spectroscopic Databases of Dodecane Isomers

Author: BenchChem Technical Support Team. **Date:** May 2026

Compound of Interest

Compound Name: 3,4-Diethyl-4-methylheptane

CAS No.: 62199-02-4

Cat. No.: B15456785

[Get Quote](#)

For researchers, scientists, and drug development professionals, the precise identification of chemical isomers is a critical step in ensuring the purity, efficacy, and safety of compounds. Dodecane (C₁₂H₂₆) and its numerous isomers are often encountered as components in complex mixtures, such as fuels and lubricants, and can serve as model compounds in various chemical studies. Distinguishing between these isomers can be challenging due to their similar physical properties. This guide provides a comparative overview of the spectroscopic data for n-dodecane and several of its branched isomers, offering a valuable resource for their differentiation and characterization.

Data Presentation: A Spectroscopic Comparison

The following tables summarize key spectroscopic data for n-dodecane and two of its isomers: 2-methyldecane and 2,2-dimethyldecane. This data highlights the distinct spectral features that arise from differences in their molecular structures.

Table 1: Mass Spectrometry (MS) Data

Isomer	Molecular Ion (m/z)	Base Peak (m/z)	Key Fragment Ions (m/z)
n-Dodecane	170 (low intensity)	43, 57	71, 85, 99, 113
2-Methyldecane	170 (very low intensity)	43, 57	155, 127, 71
2,2-Dimethyldecane	170 (absent or very weak)	57	113, 85, 71

 Table 2: ¹³C NMR Chemical Shift Data (in CDCl₃)

Isomer	C1 (ppm)	C2 (ppm)	C3 (ppm)	Other Key Signals (ppm)
n-Dodecane	~14.1	~22.7	~31.9	~29.4-29.7 (internal CH ₂)
2-Methyldecane	~22.7, ~23.0	~27.9	~39.2	~14.1 (terminal CH ₃)
2,2-Dimethyldecane	~29.0 (3C)	~30.6	~44.3	~22.7, ~31.9, ~14.1

Table 3: Infrared (IR) Spectroscopy Data

Isomer	C-H Stretching (cm ⁻¹)	C-H Bending (cm ⁻¹)	Noteworthy Features
n-Dodecane	2955, 2924, 2854	1467, 1378	Rocking vibration ~722 cm ⁻¹ (for - (CH ₂) _n - where n ≥ 4)
2-Methyldecane	2956, 2924, 2855	1466, 1378	Absence of the ~722 cm ⁻¹ rocking band.
2,2-Dimethyldecane	2954, 2906, 2869	1468, 1393, 1367	Splitting of the methyl bending mode (~1393 and 1367 cm ⁻¹) is characteristic of a gem-dimethyl group.

Experimental Protocols

The data presented in this guide is typically acquired using standard spectroscopic techniques. Below are generalized experimental protocols for each method.

Mass Spectrometry (Electron Ionization - GC-MS)

- Sample Preparation: Dilute the dodecane isomer in a volatile solvent (e.g., hexane or dichloromethane) to a concentration of approximately 1 mg/mL.
- Instrumentation: A gas chromatograph coupled to a mass spectrometer (GC-MS) is used.
- Gas Chromatography (GC) Conditions:
 - Column: A non-polar capillary column (e.g., DB-5ms, 30 m x 0.25 mm x 0.25 μm) is suitable.
 - Inlet Temperature: 250 °C.
 - Carrier Gas: Helium at a constant flow rate of 1 mL/min.
 - Oven Temperature Program: Initial temperature of 50 °C, hold for 2 minutes, then ramp at 10 °C/min to 250 °C and hold for 5 minutes.

- Mass Spectrometry (MS) Conditions:
 - Ionization Mode: Electron Ionization (EI) at 70 eV.[1]
 - Mass Analyzer: Quadrupole or Time-of-Flight (TOF).
 - Scan Range: m/z 35-350.
 - Source Temperature: 230 °C.

Nuclear Magnetic Resonance (NMR) Spectroscopy

- Sample Preparation: Dissolve 5-10 mg of the dodecane isomer in approximately 0.6 mL of deuterated chloroform (CDCl₃).
- Instrumentation: A 300 MHz or higher field NMR spectrometer.
- ¹H NMR Acquisition:
 - Acquire the spectrum with a sufficient number of scans to achieve a good signal-to-noise ratio.
 - The spectral width should cover the range of approximately -1 to 10 ppm.
- ¹³C NMR Acquisition:
 - A proton-decoupled ¹³C NMR spectrum is typically acquired.
 - The spectral width should cover the range of approximately 0 to 200 ppm.
- Data Processing: Process the raw data using appropriate software to perform Fourier transformation, phase correction, and baseline correction. Chemical shifts are referenced to the residual solvent peak (CDCl₃: δH = 7.26 ppm, δC = 77.16 ppm).

Infrared (IR) Spectroscopy

- Sample Preparation: For liquid samples like dodecane isomers, the simplest method is to place a drop of the neat liquid between two potassium bromide (KBr) or sodium chloride

(NaCl) plates. Alternatively, an Attenuated Total Reflectance (ATR) accessory can be used by placing a drop of the sample directly on the ATR crystal.

- Instrumentation: A Fourier Transform Infrared (FTIR) spectrometer.
- Data Acquisition:
 - Record a background spectrum of the empty sample holder (or clean ATR crystal).
 - Record the sample spectrum.
 - The spectrum is typically collected over a range of 4000 to 400 cm^{-1} .
 - Co-add multiple scans (e.g., 16 or 32) to improve the signal-to-noise ratio.
- Data Processing: The final spectrum is presented as transmittance or absorbance versus wavenumber (cm^{-1}).

Mandatory Visualization

The following diagrams illustrate the logical relationships in the spectroscopic analysis of dodecane isomers.

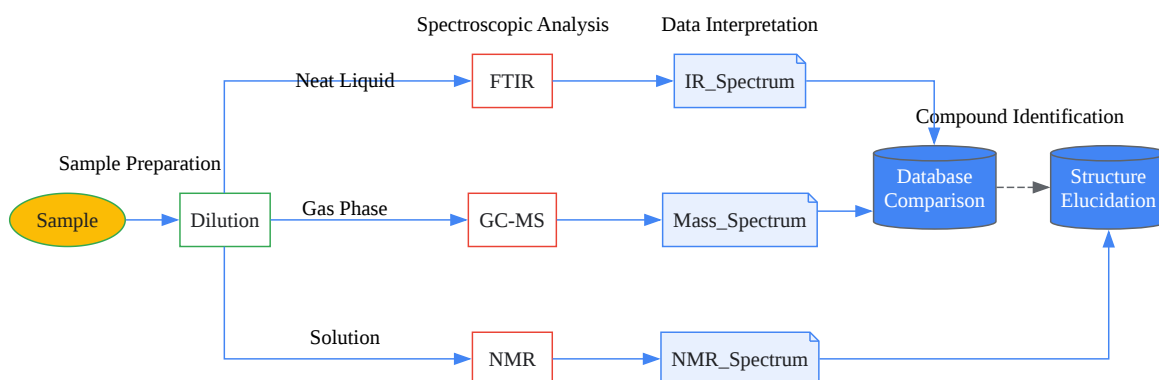

[Click to download full resolution via product page](#)

Caption: A generalized workflow for the spectroscopic analysis of dodecane isomers.

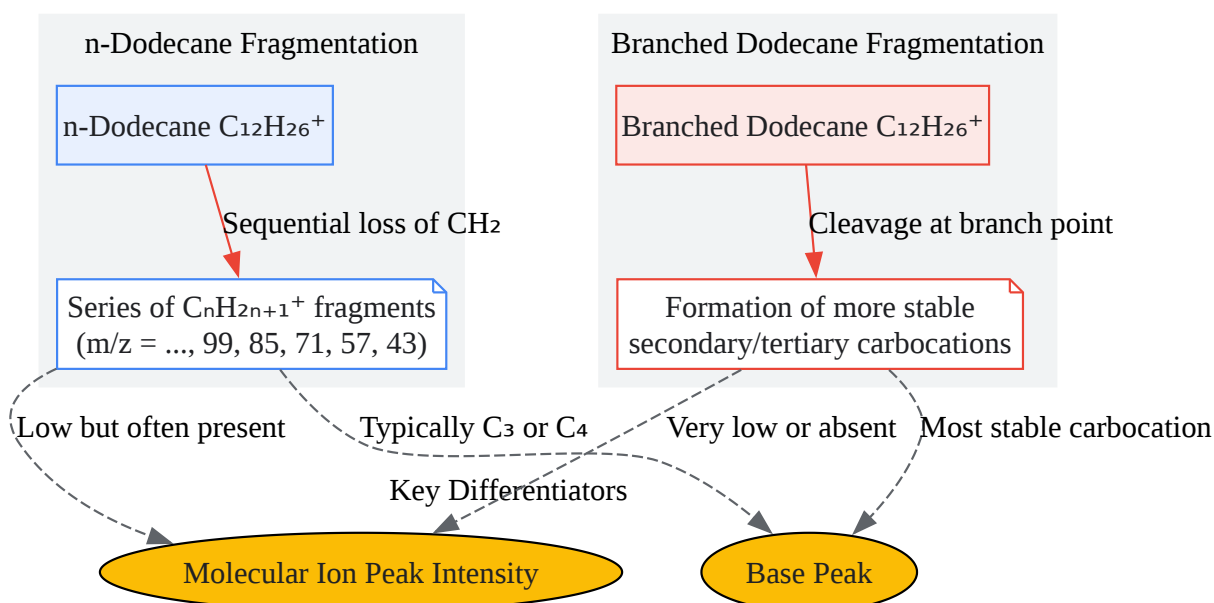

[Click to download full resolution via product page](#)

Caption: Mass spectral fragmentation pathways of linear vs. branched dodecane isomers.

In conclusion, the differentiation of dodecane isomers is readily achievable through a combined application of mass spectrometry, NMR, and IR spectroscopy. The degree of branching in the carbon chain introduces distinct and predictable variations in the spectroscopic data, providing a reliable basis for structural elucidation. Researchers can leverage these differences, in conjunction with public databases such as the NIST Chemistry WebBook, to confidently identify specific dodecane isomers in their samples.

Need Custom Synthesis?

BenchChem offers custom synthesis for rare earth carbides and specific isotopic labeling.

Email: info@benchchem.com or [Request Quote Online](#).

References

- [1. benchchem.com \[benchchem.com\]](https://www.benchchem.com)
- To cite this document: BenchChem. [A Comparative Guide to the Spectroscopic Databases of Dodecane Isomers]. BenchChem, [2026]. [Online PDF]. Available at: [\[https://www.benchchem.com/product/b15456785/docs#a-comparative-guide-to-the-spectroscopic-databases-of-dodecane-isomers\]](https://www.benchchem.com/product/b15456785/docs#a-comparative-guide-to-the-spectroscopic-databases-of-dodecane-isomers)

Disclaimer & Data Validity:

The information provided in this document is for Research Use Only (RUO) and is strictly not intended for diagnostic or therapeutic procedures. While BenchChem strives to provide accurate protocols, we make no warranties, express or implied, regarding the fitness of this product for every specific experimental setup.

Technical Support: The protocols provided are for reference purposes. Unsure if this reagent suits your experiment?

Need Industrial/Bulk Grade? [Request Custom Synthesis Quote](#)

BenchChem

Our mission is to be the trusted global source of essential and advanced chemicals, empowering scientists and researchers to drive progress in science and industry.

Contact

Address: 3281 E Guasti Rd

Ontario, CA 91761, United States

Phone: (601) 213-4426

Email: info@benchchem.com

[Contact our Ph.D. Support Team for a compatibility check](#)